



ASPHALT

Asphalt Analysis	266-269	Dynamic Testing	296-
Binder Extraction	266	Four-Point Bending	300-301
Solvent Extraction	267-269	Universal	296-299
Asphalt Binder Testing	241-265	Mix Testing	270-285
BBR	241-242	Compaction	280
Distillation	260-262	Compaction-Gyratory	272-273
Ductility	245-248	Compaction-Marshall	275-279
Flash Point	258-259	Compaction-Steel Roller	274
Ovens	244	Extraction	280
PAV	240	Load Frames	282-284
Penetration	249 -251	Load Frames Accessories	285
Rice Test	263-265	Mixers	270-271
RTFO	243	QuarterMaster	271
Softening Point	257	Water Baths	281
VDO	242-243	Road Quality	286-295
Viscosity	250-256	Asphalt Permeameter	291
		Benkelman Beam	292
		Core Drills	293-294
		Core Removal	295
		Drill Bits	295
		GPR	287
		Hamburg Wheel Tracker	288
		High-Low Detect	292
		Nuclear Gauge	286
		Polishing	290
		Skid Resistance	292
		Texas Overlay	289





H-1640B.4F



HA-1635.3F

Pressure Aging Vessel (PAV3)

ASTM D6251-05; AASHTO R28-06; EN 14769

The PAV3 pressure aging vessel is used to simulate in-service oxidative aging of asphalt binder according to procedures developed by the Strategic Highway Research Program (SHRP). The PAV3 consists of a vertical, stainless steel pressure vessel in a stainless steel cabinet with encased band heaters, a precision sample holder for simultaneous testing of ten specimens, a set of ten TFOT specimen trays, a pressure controller, temperature controller, pressure and temperature measurement devices, temperature and pressure recorder, and a specimen loading and unloading tool.

The H-1640B.4F PAV3 features a compact, bench-top design with integral ASME code section VIII, division 1; 1992 A 93 pressure vessel controlled using a 7", full-color, touch-screen display, which is tilted for greater visibility. Operating pressure is 2.10 ±0.05 MPa (304psi). Temperature is 80 to 115°C (176 to 239°F) and programmable from 50 to 150°C (122 to 302°F). Between 80 to 115°C (176 to 239°F) the tolerance is well within ± 0.1°C. Temperature uniformity is ± 0.5°C. Pressurization is programmable from 1 hour to 99 hours. This enables AASHTO R28, ASTM D6251, and EN 14769 specifications to be met without any special programming and also enables greater freedom for research and development projects. Real-time graphs are visible from the touch-screen controller while the unit's network-ready modem enables the PAV3 to be controlled from PCs and mobile devices when connected to a network.

Data acquisition of temperature, pressure, and time is collected throughout the aging process. Once the aging process is complete, a .csv file can be created and saved via the USB port on the front of the PAV3. Once the .csv file has been created, it can easily be viewed and manipulated in Microsoft

Excel® or other spreadsheet programs.

The PAV3 sample holder is a one-piece, solid device requiring no assembly and is easy to achieve an accurate level position with the leveling ring in the vessel. There is also room for a small bubble level between slots for verification purposes.

The PAV3 includes a network-ready modem, which provides connection to the internet, permitting the user to access the PAV3 with a mobile device or PC using a VNC viewer app program. VNC connection enables the user to connect, monitor, and control the PAV3 from a remote location. The PAV3 can be programmed with a custom IP address, so the number of PAV3s on a single network is essentially endless.

Pressure Aging Vessel, 230V 50/60Hz H-1640B.4F
 Shipping wt. 433 lbs (193kg)

H-1640B.4F PAV3 Accessories & Components

Description	Model
UPS battery backup system	H-1640.1
PAV verification kit	H-1640.2
PAV o-ring	H-1640.3
CGA adapter	H-1640.4
High-pressure hose	H-1640.5
Specimen pans set	H-1640.6
Regulator, single-stage	H-1640.7
Pan handling tool	H-1640.8
Specimen rack	H-1640.9

H-1635.3F PAV Accessories & Components

Description	Model
PAV verification kit	H-1635.1
Stainless Specimen pans set	H-1635.2

Pressure Aging Vessel

ASTM D6251; AASHTO R28; EN 14769

Cooper Technology's New Generation Pressure Aging Vessel uses heated, pressurised air to simulate longterm oxidative aging of asphalt binders. The PAV consist of an ASME Boiler and Pressure Vessel Code and CE certified stainless steel pressure vessel, steel cabinet with encased band heaters, and integral pressure measurement control.

Includes a platinum RTD device to ensure accurate temperature resolution and uniformity. A pressure relief valve and high- temperature thermal shutdown are included as standard safety features. A USB port located on the front of the unit allows the user to easily store test data and upgrade software when necessary. This Pressure Aging Vessel uses a touch-screen controller with front panel user interface for complete control and monitoring of all test processes. The system has an operating pressure range of 2.1 ±0.1MPa and temperature range of 80°—115°C, with resolution of 0.1°C.

This easy-to-use system completes a test in three simple steps: Set the temperature and pressure, Insert specimens, Press the start button.

Features

- Includes touch-screen controller with front panel user interface with easy -o-use step-through operation
- Bench top unit with integral vessel/oven design and top opening door
- Thermo Regulation: Proportional control with integral and derivative function
- Platinum RTD temperature measurement

The Pressure Aging Vessel includes a set of ten specimen pans, a precision, anodized aluminum sample holder with lifting handle, and a specimen handling tool. Additional pans can be ordered as necessary. Compressed air with a pressure of at least 350psi (2.4MPa) and a regulator must be user provided.

Pressure Aging Vessel, 120/220V 50/60Hz H-1635.3F
 Shipping wt. 433 lbs (193kg)





H-1642T

Bending Beam Rheometer with Touch Screen

ASTM D6648; AASHTO T313, TP87 BS EN 14771

The Bending Beam Rheometer 3 (BBR3) has been designed to perform flexural tests on asphalt binder and similar specimens as part of the PG grading system according to Superpave. The BBR3 is a state of the art internal computer system incorporating touchscreen technology. The BBR3's new external cooling unit is now more compact and omits less noise during operation. Programmable test parameters allow users to input and save their own unique settings, allowing the BBR3 to satisfy a diverse range of testing applications.

The BBR3 is made up of a fluid bath base with a built-in touchscreen computer, load frame, external refrigeration unit, and a calibration kit with carrying case. During operation, a known force is applied to the center of a horizontally supported specimen beam submerged in a cold liquid bath while internal software calculates the flexural creep stiffness of the beam. Used in part to determine a sample's critical cracking temperature and low temperature PG grade, the BBR3's -40°C to 25°C temperature range is efficiently calculated by a platinum RTD measuring device. The 500g load cell and changeable specimen supports easily transition the BBR3 for crack sealant testing, and the free standing external cooling unit ensures that the cooling fluid maintains a constant temperature.

Programmable test parameters allow the user to define a test and save those parameters for later testing. Predefined test parameters include the standard ASTM BBR test, as well as the crack sealant test and the sliver test.

The BBR3's programmable test parameters include: Deflection Plot, Load Plot, Bath Temperature, Stirrer Speed, Specimen size, Testing Times, Load, and Testing Company.

The BBR3 features a Displacement Transducer

accuracy of 0.097 micron, a measurement resolution of 0.006g, and a Deformation Accuracy of 0.097. While other BBR models may favor Peltier cooling, the BBR3 operates more efficiently without it.

Reporting features on the new BBR3 include the ability to name your sample and enter any important notes. With the new BBR3, your data is collected twice per second in addition to these

new features, BBR3 users now also have the ability to upload their company logo directly into their test report.

Once the BBR3 has been connected to a network, users have the ability to access their equipment using a mobile phone, tablet, or PC. This also allows users to connect to a wireless printer, making it easy to print data and test results. A USB port on the back of the unit is also available for users who prefer to connect a printer directly.

In addition to the USB port on the back of the BBR3, a USB port on the front of the unit allows for user friendly software updates. Operators can also use this USB port to download data onto a flashdrive, or connect a wireless keyboard for more efficient data input.

BBR3 Touch, 120V 60Hz H-1642T
 BBR3 Touch, 230V 50/60Hz H-1642T.4F
CE Shipping wt. 250 lbs (115kg)

BBR Accessories & Components*

Description	Model
Specimen Mold Set (5 per set)	H-1642.1
Mylar Strips, 5 sets of 3 ea.	H-1642.2
BBR Calibration Kit	H-1642.3

* For use with all BBRs H-1642T, H-1642T.5F, H-1642 and H-1642.5F

H-1642T Specifications	
Power Requirements	120, 1ph, 50/60 Hz
Operating Temperature	Ambient to -40°C
Test Load	Variable test range from 0 to 4,000 mN standard. System. Maintains required test load within +/- 5mN throughout test cycle.
Test Cycle Times	Cycle times for pre-load, recovery, and test load are completely operator adjustable
Load Cell	500g (temperature compensated)
LVDT Displacement Transducer	6.35mm (0.25") calibrated range to provide 2µm resolution throughout testing and verification range.
Recommended Cooling Bath Fluid	Non-flammable ethylene glycol mixture
Temperature Measurement	Platinum RTD
Compressed Air Requirements	60 PSI inlet pressure (414 kpa) @ Class 3 Quality max particle of 5µm
Weight	Approximately 148 lbs.
Dimensions	24" W x 23.5" H x 26.5" D



H-1642

Bending Beam Rheometer

ASTM D6648; AASHTO T313-02

The bending beam rheometer (BBR) performs flexural tests on asphalt binder and similar specimens per tests, initially developed by the Strategic Highway Research Program (SHRP), which consist of a constant force being applied to a specimen in a

H-1642 Specifications	
Power Requirements	115V 60Hz or 230V, 1ph, 50/60 Hz
Temperature Range	-40 to 25°C
Operating Temperature	Ambient to -40°C
Test Load	Variable range from 0-200g standard within +/- .5g
Test Cycle Times	Cycle times for pre-load, recovery, and test load are completely operator adjustable
Load Cell	500g (temperature compensated)
LVDT Displacement Transducer	0.25 in. (6.35 mm.) calibrated range to provide 2um resolution throughout testing and verification range
Recommended Cooling Bath Fluid	Non-flammable ethylene glycol mixture
Coolant Capacity	2 gallons (7.57 liters)
Temperature Measurement	Platinum RTD
Compressed Air Requirements	50 psi (0.34 MPa) clean, dry air supply required
Dimensions	24.125" W x 24.125" D x 23.25" H (w/ load frame)
Weight	Approximately 270 lbs.

chilled fluid bath in order to derive specific rates of deformation at various temperatures. The complete BBR system consists of a fluid bath base unit, a three-point bend test apparatus, which is easily removed from the base unit for specimen loading and unloading, an external cooling unit with temperature controller and a calibration hardware kit with carrying case. The unit features an integral, stainless steel load frame and in-line, blunt-point loading shaft. The large, easy-to-read digital display shows load, displacement, and bath temperature for ease of setup and operation. Real-time displacement, loading, and temperature graphs are displayed during the test cycle and can be re-plotted and re-scaled as needed for easy viewing.

The BBR uses a linear, variable-displacement transducer (LVDT) with a range of 6.35mm and accuracy to $\pm 2\text{mm}$ measures deflection. The temperature-compensating 500g load cell with mechanical overload protection ensures accurate load results. Safe, rapid cooling of the ethylene glycol mixture test fluid to -40° to 25°C is provided by a mechanical refrigeration system. Process temperature is controlled and monitored by two, independent, platinum RTD temperature transducers maintaining temperature stability.

The BBR comes with a pre-loaded software package, which allows for device configuration, daily verifications, test setup, test initiation, and reporting. It also includes five aluminum specimen molds with mylar strips, a Calibration Kit with required weights, and confidence beam. Calibrated test weights and a certified LVDT (NIST-traceable). The easy-to-use software allows daily verification and periodic calibration of load cell, LVDT, and RTD transducers. Dimensions: 49" x 49" x 41" (1,245 x 1,245 x 1,040mm). An adequate compressed air source must be supplied by user.

Bending Beam Rheometer, 120V 60Hz H-1642
 Bending Beam Rheometer, 230V 50Hz H-1642.5F
 Shipping wt. 520 lbs (235.8kg)



H-1641T

Vacuum Degassing Oven (VDO Touch)

ASTM D6521-05; AASHTO R28-06

The vacuum degassing oven (VDO touch) is used to precisely and accurately degas pressure-aged binder samples and is designed for rapid removal of entrapped air bubbles in asphalt specimens to the required $15 \pm 1.0\text{kPa}$ (25.5Hg). The network-ready 7in (178mm) touch-screen controller features easy menu-driven operation in multiple language options for fast programming of vacuum, temperature values and soak times. The controller display indicates time, temperature, and current process stage, with alerts at the end of each test. When connected to a network with an Ethernet cable, the VDO Touch can be operated remotely via smart phones, tablets, or PC's. USB Ports allow easy software upgrades.

The compact, table-top unit is constructed of stainless steel with a hinged lid to conserve space while allowing easy access to the stainless steel vacuum chamber. The oven holds up to (8) 4 oz. (114ml) or (4) 8 oz. (236ml) sample containers and features a self-contained, automatic vacuum system.

Temperatures in the VDO Touch vacuum chamber are measured by a platinum RTD probe with a range from ambient to 200°C with accuracy to $\pm 5^{\circ}\text{C}$. Soak and degassing times are both programmable up to 4,320 minutes. The rugged stainless steel cabinet, chamber and cover are easy to maintain, and the removable cover features a heat-resistant glass viewing window for monitoring purposes. The VDO includes (4) 236ml (8oz) sample tins, and a specimen removal tool for easy loading and unloading of samples. Dimensions: 24" x 16" x 12" (610 x 406 x 304mm). *continued on next page*

H-1641T Specifications	
Operating pressure	$15 \pm 1.0\text{ kPa}$ (25.5Hg)
Temperature range	Ambient to 200°C
Temp. resolution	0.1°C
Accuracy	$\pm 5^{\circ}\text{C}$



continued from previous page

H-1641T VDO Features:

- Automated tabletop degassing oven for rapid removal of entrapped air bubbles in asphalt specimens
- Network-ready, 7" touchscreen controller provides simple control to input vacuum, temperature and soak time values
- Ethernet cable connection enables remote operation via smart device
- Capacity for eight 4oz (118ml) or four 8oz (236ml) sample containers

Vacuum Degassing Oven, 120V 60Hz H-1641T
 Vacuum Degassing Oven, 230V 50/60Hz H-1641T.4F
Shipping wt. 185 lbs (84kg)

H-1641T VDO Accessories & Components

Description	Model
UPS battery backup system	H-1640.1
VDO verification kit	H-1641.7
Sample container, 8 oz. (236ml) 4 (pk)	H-1641T.1A
VDO verification thermometer	H-1641T.2
VDO vacuum verification gauge	H-1641T.3
VDO calibration block	H-1641T.4
VDO vessel cap	H-1641T.5

Rolling Thin Film Oven

ASTM D2872; AASHTO T240; EN 12591;CTM 346

The Rolling Thin Film Oven (RTFO) is used to measure the effect of heat and air on a moving film of semi-solid asphaltic material and is an indicator of the approximate change in properties during conventional hot-mixing. The results of this treatment are determined from measurements of the asphalt properties before and after the test. Through the use of a programmable, temperature controller and a 4-digit, digital display system, along with a solid-state heater and 200-watt heating element, the oven accurately maintains the specified test temperature of ±1°F at 325°F (±0.5°C at 163°C).

The oven also features: double-wall construction; door with double-pane viewing window; symmetrical top and bottom vents; air plenum, and squirrel-cage-type 1725 rpm fan

The RTFO is available in a standard model with a glass flow meter or with a digital flow meter. Both models are identical other than the meter.

The RTFO oven includes:

- 200 to 14,000 ml/min flow meter
- Moisture meter
- 0 to 100 psi air pressure gauge with regulator
- Rotating (15rpm) test rack.
- 8 Glass sample containers

Overall dimensions 40"W x 36"H x 26"D (1016 x 3292 x 660mm). A clean, dry compressed air source is required for oven operation.

RTFO, 208-230V 60Hz H-30068.2F
 RTFO, 208-230V 50Hz H-30068.5F

Digital RTFO, 208-230V 60Hz H-30069.2F
 Digital RTFO, 208-230V 50Hz H-30069.5F

Shipping wt. 480 lbs (217.7kg)

Specifications

Construction	Double-walled, 16-gauge welded steel exterior. 18-gauge corrosion-resistant, stainless steel interior
Insulation	Insulation 3.5" (89mm) of high density fiberglass
Controller	Programmable microprocessor, UL listed
Temperature Display	Measured Temperature: 4 digit red LEDs Temperature Set Point: 4 digit green LEDs
Thermal Protection	Prevents overheating in the event of control failure
Temperature Range	Ambient to 390°F (200°C)
Vents	Double exhaust vents for dissipation of expended volatile from specimen
Air Flow Adjustment	Needle valve (long taper)
Air Pressure Gauge	Range 0 - 100 psi
Heat Exchanger	5/16" dia. copper tube

Rolling Thin Film Oven Accessories

Lab stand with wheels	H-30068.6
Silica gel, 1.5 lb can	H-30068.7
Dry air system	H-30068.8
Jar cooling rack	H-30068.3
Bottle scraper	H-30068.2
Digital mass flow-meter	H-30068.9
ASTM 13C Thermometer	H-2610.13C
Additional specimen bottles	H-30068.12
Oven Tongs	H-30068.1



ACCESSORIES

Accessories are not included and should be ordered separately.



H-1631

Loss-on-Heat Thin Film Oven

ASTM D6, D1754; AASHTO T47, T179; BS2000

This dual-purpose 16ft³ oven can be used for loss-of-heat test and thin film test for bitumen and asphaltic materials. The loss-on-heat oven determines the effect on asphaltic materials of heating in an oven under prescribed conditions. The results are reported in terms of change in sample mass and/or changes in selected properties such as viscosity, penetration and ductility as evidenced by test data taken before and after the oven cycle.

The oven features a stainless steel interior, a powder-coated steel exterior and a double-glazed door window for viewing the test chamber. Side-mounted controls are comprised of a microprocessor digital control and an independent overheat thermostat. Two rotating platforms are supplied to perform both types of tests.

The oven's temperature range is: ambient to 365°F (180°C), pre-set to 163°C ± 1°C. **Dimensions:** Internal Chamber: 15" (H) x 20.5" (W) x 18" (D) (38 x 52 x 46cm); external dimension 22.5" (H) x 34" (W) x 25" (D) (57 x 87 x 63cm). External Dimension does not include motor or handle.

Loss-On-Heat Oven, 120V 60Hz **H-1631**
 Loss-On-Heat Oven, 220V 50Hz **H-1631.5F**
Shipping wt. 300 lbs (136kg)

Loss-On-Heat Oven Accessories

Description	Model
Sample container, ASTM D6	H-1631.1
Thin film oven pan, stainless steel for ASTM D1754	H-1540

Pyrolytic Oven

This new Pyrolytic Oven from ATS is a must have for any testing lab. Designed to burn off test residue from lab equipment, this oven performs safe, solvent-free cleaning of asphalt and other organic residues from laboratory equipment and glassware. The Pyrolytic Oven provides fully-automatic cleaning cycles and cost-effective operation while reducing hazardous waste handling and disposal.



H-1647.2F

This model improves on previous versions and incorporates state-of-the-art touchscreen technology, automatic operation, and a clean, matte-black design. Lab technicians no longer need to rely on scraping, wire brushing, or hand heating to clean equipment. Operators can simply place everything in their pyrolytic oven, press start, and allow the machine to do the work. This not only reduces mess, but saves time and creates a safer, more efficient lab environment.

The Pyrolytic Oven's touchscreen controller provides user-friendly operation with menu-driven programming, which allows completely automatic operation. System monitoring diagnostics provides alerts to operators when maintenance is required. Pre-programmed language options include English, German, French, Italian, Chinese, Spanish, and Arabic. The clean, matte-black design fits the physical footprint and exhaust connection point of older Pyro-Clean models.

Maximum oven temperature is 900°F (482°C) and cleaning temperatures range from 800° to 900°F to burn off organic contaminants, leaving behind only carbonized residue, which can be easily removed.

Features:

- Low operating costs allows users to save both time and money.
- User-friendly touchscreen technology and enhanced ATS software.
- Eliminates the need to hand clean equipment
- Destroys even trace residues of organic contaminants, leaving lab equipment ultra clean for critical testing.
- Reduces or eliminates the costs of hazardous waste material disposal, the dangers of glass breakage, and the overall mess associated with manual equipment cleaning.
- Pre-programmed language options include English, German, French, Italian, Chinese, Spanish, and Arabic.
- Developed utilizing more than 50 years of process heating and materials testing industry experience.



H-30145E

- Built-in system monitoring diagnostics to alert operators when maintenance is required.
- Fits physical footprint and exhaust connection point of previous, obsolete pyrolytic oven models.

Pyrolytic Oven, 220V 60Hz **H-1647.2F**
Shipping wt. 380 lbs (172kg)

Heavy-Duty Lab Bench Oven

ASTM D6925

Forced draft oven capable of maintaining 437°F (225°C), more than adequate for both short-term aging of asphalt samples and heating aggregates, asphalt binders and equipment for use in ASTM D6925. The .7ft³ (19L) capacity provides ample room for all applications. The oven features a calibrated dial-type temperature controller (model H-30145) or a digital PID microprocessor temperature controller (model H-30145E). These ovens are constructed of corrosion-resistant, aluminized steel interiors and exteriors coated in an exclusive "high-tech" bronze polyester finish. The large, high-impact thermal plastic door handles provide durability and remain cool-to-the-touch during operation. Ovens come with (2) heavy-duty, chrome-plated wire shelves, which can support 80 lbs. (36kg).

Dimensions: Internal Chamber: 26" (H) x 20" (W) x 26" (D) (660 x 508 x 660mm); external dimension 33" (H) x 24" (W) x 32" (D) (838 x 610 x 813mm).

Lab Bench Oven, 120V 60Hz **H-30145**
 Lab Bench Oven, 230V 50/60Hz **H-30145.4F**
 Lab Bench Oven, 120V 60Hz **H-30145E**
 Lab Bench Oven, 230V 50/60Hz **H-30145E.4F**
Shipping wt. 206 lbs (93.4kg)

Heavy-Duty Lab Oven Accessories

Description	Part #
Floor Stand, 1 fixed shelf	H-30150
Floor cabinet, 2 sliding shelves	H-30155
Exhaust adapter for 3" pipe	H-30181
Shelf w/ mounting rails	H-30145S



ACCESSORIES

For more bench oven choices, as well as accessories, see page: 334-340. For gloves for use with these ovens, see page 352.





Interior of HA-1068 showing test molds, screw drive and disengage lever.

Elite Series Automated Ductilometer

ASTM D113, D5892, D6084,

The HA-1068 Ductilometer features Humboldt's Elite Series Controller. This touch-screen controller provides you with full, graphical monitoring of all testing functions in a stand-alone application, while also providing the ability to control the machine from a networked computer or just port data from the controller to a networked computer.

The HA-1068 Controller provides precise speed control of the DC, stepper motor maintaining constant speed, entirely vibration-free, from 5 to 100mm/min. The unit provides for three test briquettes per testing sequence with a maximum carriage travel (elongation) of 150cm and an automatic stop feature. The machine also provides a manual disengage lever for quickly disengaging the screw drive to return the testing carriage back to the start position after a test completion. This feature allows multiple tests to be run without having to wait for the machine to reset itself.

The HA-1068 has a stainless steel interior with an overflow connection, and a baked enamel stainless steel-wrapped exterior. Gears are bronze or brass; all other parts are solid brass to prevent rusting. Finned stainless steel tubes beneath a false bottom provide efficient thermal transfer. A single stainless steel lead screw mounted above water level prevents agitation of water and premature rupture of specimens. A traveling pointer adjusts to zero starting position and indicates exact position of carriage on a linear centimeter scale attached to trough's front edge.

Stand-Alone Control

In stand-alone mode the controller provides you with full, graphical monitoring of all testing functions, while maintaining full computer control when desired. The seven-inch, waterproof screen provides at-a-glance monitoring of testing functions, in a real-time graphical display, without the use of a computer, building upon Humboldt's dedication to modular, stand-alone data acquisition.

You will be able to run tests and display results while viewing tabulation, basic x-y graphs and instrument readings in real-time during the test, using user-defined, basic data acquisition. Test data is stored in the device and can be downloaded to a USB drive via the machine's FRONT USB port or the data can be transferred to a computer via the LAN port.

A second USB port located on the back of the machine can also be used to power a wireless access point, which can provide a wireless hook-up with a computer, if no LAN is available.

The HA-1068 Ductilometer is sold without a circulating temperature controller. If desired, choose a circulating temperature controller with the correct AC requirements. The temperature-controller provides a solid-state, thermostatically controlled bath and circulator to maintain water temperature within a $\pm 0.9^{\circ}\text{F}$ ($\pm 0.5^{\circ}\text{C}$). The temperature range is:

-10°C to 80°C and the heating capacity is 1000W with a 0.1°C stability. Includes a 6' (183cm) cord, feed-through switch and 3-prong plug and 3 standard H-1080 briquette molds with H-1090 plates. Trough overall dimensions: 11.75" x 74" x 6.375" H (30 x 188 x 16cm). Acrylic Cover is included with this machine.

Elite Series Ductilometer, 120/220V 50/60Hz HA-1068.3F
Shipping wt. 425 lbs (193kg)

Circulating Temperature Controller

The H-1068CB Circulating Temperature Controller is designed for use with the H-1068X ductility machine. It provides a solid-state, thermostatically controlled bath and circulator to maintain water temperature within a $\pm 0.9^{\circ}\text{F}$ ($\pm 0.5^{\circ}\text{C}$). Temperature range is: -10°C to 80°C. 1000W heating capacity with 0.1°C stability. Dimensions: 25" x 9" x 19" (635 x 229 x 483mm).

Circulating Temp. Control, 120V 60Hz H-1068CB
Circulating Temp. Control, 220V 60Hz H-1068CB.2F
Circulating Temp. Control, 220V 50Hz H-1068CB.5F
Shipping wt. 80 lbs (36.2kg)



Interior of HA-1060 showing force determination transducer set up.



Interior of HA-1060 showing test molds, screw drive and disengage lever.



HA-1060.4F

Elite Series Ductilometer, Refrigerated ASTM D113, D5892, D6084, AASHTO T51

Humboldt's Elite Series refrigerated Ductilometer features Humboldt's Elite Series Controller. This touch-screen controller provides you with full, graphical monitoring of all testing functions in a stand-alone application.

The HA-1060 Refrigerated Ductilometer is mounted into a polypropylene bath designed for use with sodium chloride solutions. The cabinet is constructed of a heavy-gauge, enamel-finish steel lower cabinet and stainless steel upper cabinet. It is fully-insulated and the sealed space between the inner and outer walls protects the low-thermal conductivity properties of the foam and fiberglass combination (tested and proven to have the best K factor). A high-capacity pump assures positive circulation in the bath to provide close temperature control. Three-direction flow regulation is handled with flow cut-off valves that engage when equilibrium is reached. A sensitive, magnetic-setting, electronic relay control panel for heat and refrigeration maintains temperature range of 32°F (0°C) to 86°F (30°C) by 0.1°F (0.1°C).

The HA-1060 Controller provides precise speed control of the DC, direct-drive motor maintaining constant speed, entirely vibration-free, from

5 to 100mm/min. The unit provides for three test briquettes per testing sequence with a maximum carriage travel (elongation) of 150cm and an automatic stop feature. The machine also provides a manual disengage lever for quickly disengaging the screw drive to return the testing carriage back to the start position after a test completion. This feature allows multiple tests to be run without having to wait for the machine to reset itself.

The HA-1060 has a stainless steel interior with an overflow connection, and a baked enamel stainless steel-wrapped exterior. Gears are bronze or brass; all other parts are solid brass to prevent rusting. Finned stainless steel tubes beneath a false bottom provide efficient thermal transfer. A single stainless steel lead screw mounted above water level prevents agitation of water and premature rupture of specimens. A traveling pointer adjusts to zero starting position and indicates exact position of carriage on a linear centimeter scale attached to trough's front edge.

Stand-Alone Control

In stand-alone mode the controller provides you with full, graphical monitoring of all testing functions, while maintaining full computer control when desired. The seven-inch, waterproof screen provides at-a-glance monitoring of testing functions,

in a real-time graphical display, without the use of a computer, building upon Humboldt's dedication to modular, stand-alone data acquisition.

You will be able to run tests and display results while viewing tabulation, basic x-y graphs and instrument readings in real-time during the test, using user-defined, basic data acquisition. Test data is stored in the device and can be downloaded to a USB drive via the machine's FRONT USB port or the data can be transferred to a computer via the LAN port. A second USB port located on the back of the machine can also be used to power a wireless access point, which can provide a wireless hook-up with a computer, if no LAN is available.

Includes 3 standard H-1080 briquette molds with H-1090 plates and an integral, clear acrylic cover to aid in temperature control. Cabinet is 90" x 41" x 23" (229 x 104 x 58cm).

Elite Ductilometer, Refrig., 220V 50/60Hz HA-1060.4F
Shipping wt. 1066 lbs (484kg)



Humboldt Ductilometer

ASTM D113, D5892, D6084, AASHTO T51

Humboldt Ductilometers determine ductility of formed asphalt/cement or semi-solid bitumen by measuring the distance of elongation before reaching the breaking point of a briquette sample, which is pulled apart at a specific speed and temperature. The H-1068X is a three-speed machine designed for standard and force ductility tests. The unit tests three briquettes simultaneously and its DC, direct-drive motor maintains constant speed, entirely vibration-free. Speeds of 1/4, 1 or 5cm per minute are selected via lever shift on mechanical gear box.

A single stainless steel lead screw mounted above water level prevents agitation of water and premature rupture of specimens. A traveling pointer adjusts to zero starting position and indicates exact position of carriage on a linear centimeter scale attached to trough's front edge. Maximum carriage travel (elongation) is 150cm with an automatic stop.

The Unit has a stainless steel interior with an overflow connection, and a baked enamel stainless steel-wrapped exterior. Gears are bronze or brass; all other parts are solid brass to prevent rusting. Finned stainless steel tubes beneath a false bottom provide efficient thermal transfer. Includes a 6' (183cm) cord, feed-through switch and 3-prong plug. Includes 3 standard H-1080 briquette molds with H-1090 plates. Trough overall dimensions: 11.75" x 74" x 6.375"H (30 x 188 x 16cm). H-1068PC Acrylic Cover is recommended to maintain constant tank temperatures.

Humboldt Ductilometer	
Humboldt Ductilometer, 120V 60Hz	H-1068X
Humboldt Ductilometer, 220V 60Hz	H-1068X.2F
Humboldt Ductilometer, 220V 50Hz	H-1068X.5F
Shipping wt. 240 lbs (108.8kg)	

Ductilometer, Temperature-Controlled

ASTM D113, D5892, D6084, AASHTO T51

The H-1068 Ductilometer builds on the H-1068X machine and adds a circulating temperature-control unit. Solid-state thermostatically controlled bath and circulator maintain water temperature within a $\pm 0.18^\circ\text{F}$ ($\pm 0.1^\circ\text{C}$). The H-1068B is a three-speed machine designed for Standard and Force Ductility tests. The unit tests three briquettes simultaneously and its DC, direct-drive motor maintains constant speed, entirely vibration-free. Speeds of 1/4, 1 or 5cm per minute are selected via lever shift on mechanical gear box.

A single stainless steel lead screw mounted above water level prevents agitation of water and premature rupture of specimens. A traveling pointer adjusts to zero starting position and indicates exact position of carriage on a linear centimeter scale attached to trough's front edge. Maximum carriage travel (elongation) is 150cm with an automatic stop.

The Unit has a stainless steel interior with an overflow connection, and a baked-enamel, stainless steel-wrapped exterior. Gears are bronze or brass; all other parts are solid brass to prevent rusting. Finned stainless steel tubes beneath a false bottom provide efficient thermal transfer. Includes a 6' (183cm) cord, feed-through switch and 3-prong plug. Includes 3 standard H-1080 briquette molds with H-1090 plates. Trough overall dimensions: 11.75" x 74" x 6.375"H (30 x 188 x 16cm). H-1068PC Acrylic Cover is recommended to maintain constant tank temperatures.

Ductilometer, Temperature Controlled	
Ductilometer, 120V 60Hz	H-1068B
Ductilometer, 220V 60Hz	H-1068B.2F
Ductilometer, 220V 50Hz	H-1068B.5F
Shipping wt. 410 lbs (185.9kg)	

Ductility Machine, Basic

ASTM D113, D5892, D6084, AASHTO T51

The H-1050 is a three-speed machine designed for standard and force ductility tests. It includes a quality mechanical gear box. Speeds of 1/4, 1 or 5cm per minute are selected via lever shift on mechanical gear box. The unit is a bare-bones, economical ductility machine, which does NOT include a wrapped exterior or thermal-finned, stainless steel tubes for enhanced thermal transfer.

Ductility Machine, Basic, 120V 60Hz	H-1050
Ductility Machine, Basic, 220V 60Hz	H-1050.2F
Ductility Machine, Basic, 220V 50Hz	H-1050.5F
Shipping wt. 200 lbs (90.7kg)	

Circulating Temperature Controller

The H-1068CB Circulating Temperature Controller is designed for use with the H-1068X ductility machine. It provides a solid-state, thermostatically controlled bath and circulator to maintain water temperature within a $\pm 0.9^\circ\text{F}$ ($\pm 0.5^\circ\text{C}$). Temperature range is: -10°C to 80°C . 1000W heating capacity with 0.1°C stability. Dimensions: 25" x 9" x 19" (635 x 229 x 483mm).

Circulating Temp.Control, 120V 60Hz	H-1068CB
Circulating Temp.Control, 220V 60Hz	H-1068CB.2F
Circulating Temp.Control, 220V 50Hz	H-1068CB.5F
Shipping wt. 80 lbs (36.2kg)	



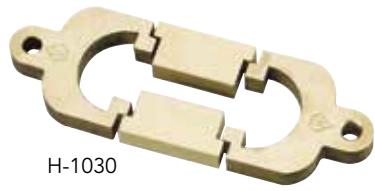

H-1030

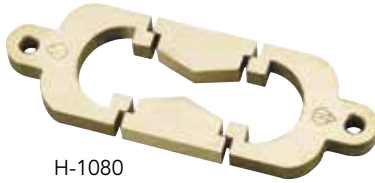

H-1080

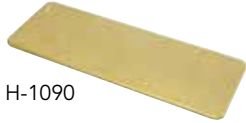

H-1090

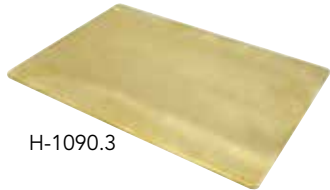

H-1090.3

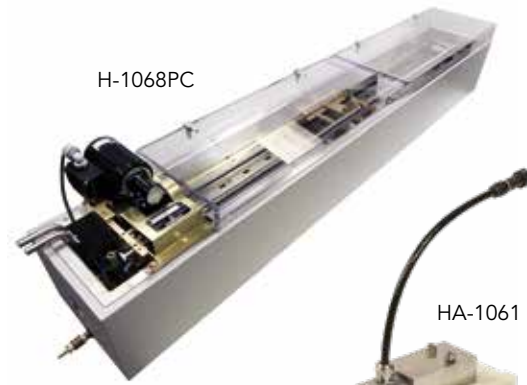

H-1068PC



HA-1061



H-1068.100



HA-1062



5320



HA-1063

Ductility Briquette Mold

ASTM D113

Mold for making test briquettes for use with any ductility testing machine. H-1080 briquette mold has angled sides for use in standard test. Four accurately machined interlocking brass segments are interchangeable with same parts from different molds; no parts identification marks are needed for matching. End pieces, designed to hold specimens being elongated, are provided with mounting holes.

Ductility Briquette Mold H-1080
Shipping wt. 0.8 lb (0.36kg)

Elastic Recovery Mold

ASTM D5892, D6084, AASHTO T301

Mold for making test briquettes for use with any ductility testing machine. H-1030 briquette mold has straight sides for use in forced tests. Requires H-1090 or H-1090.3 base plates. Four accurately machined interlocking brass segments are interchangeable with same parts from different molds; no parts identification marks are needed for matching. End pieces, designed to hold specimens being elongated, are provided with mounting holes.

Elastic Recovery Mold H-1030
Shipping wt. 1.1 lb (0.49kg)

Base Plate

Brass, base plate for single mold. Flat surface provides uniform contact with mold and surfaces. 5.5" x 2" x .125" (140 x 51 x 3mm)

Base Plate, Single Mold H-1090
Shipping wt. 0.6 lbs (0.27kg)

Base Plate, Triple Mold

Brass base plate for triple mold. Flat surface provides uniform contact with bottom surfaces mold. 5.5" x 8" x .125" (140 x 203 x 3mm)

Base Plate, Triple Mold H-1090.3
Shipping wt. 1.8 lbs (0.8kg)

Cover for Ductilometers (Clear, Acrylic)

Temperature control cover made from clear acrylic sheet. Can be used with all ductility machines, except HA-1060, which comes with one.

Ductility Machine Cover H-1068PC
Shipping wt. 40 lbs (18kg)

Ductilometer Stand

Designed for use with Humboldt Ductilometers, places machine at working height and includes a shelf for circulating temperature controller. Features square steel legs. Needs assembly.

Ductilometer Stand H-1068.100
Shipping wt. 200 lbs (90.7kg)

Force Determination Transducers

Force determination transducers for use with Humboldt Elite Series Ductilometers. Provides precise tensile strength measurement of any material, preparation, procedure or type of test to an accuracy of 0.01 lbs. Attaches over existing pin in Ductilometer without tools or machine modification. Can accommodate three adapters simultaneously. Electric components are located out of the water bath. Sold individually, Elite Series Ductilometer can accommodate up to 3 at a time.

Force Determination Transducer HA-1061
Shipping wt. 4 lbs (2.3kg)

Calibration Device, Force Transducers

Calibration device for Humboldt Elite Series Ductilometer force determination transducers. Provides simple and precise calibration of transducers. Includes calibration pedestal, storage pedestal, dead weight hanger and weight set.

Calibration Device, Force Transducers HA-1062
Shipping wt. 15 lbs (6.8kg)

Force Determination Kit for Ductilometers

This force determination kit is designed for use with manual control ductilometers like the H-1068X and H-1068B. It provides (3) Force Determination Transducers, a HM-5320 Data Logger and (1) Force Transducer Calibration Device. This kit will allow you to do force determinations and the Data Logger will allow you to monitor the test and its results. Humboldt's Elite Series Data Logger provides four individual, 24-bit analog to digital converters with an instrumentation excitation supply of 10 VDC. The analog Logger is ideal for use with instruments, such as pressure transducers, load cells, and strain transducers. It provides data storage for 1000 readings per channel. See page 145 for more information.

Force Determination Kit HA-1063
Shipping wt. 30 lbs (13.6kg)





H-1200



H-1240



H-1240D



H-1250



H-1252

Penetrometer, Universal

ASTM D5, D217, D1168, D1321, D1403, D1831, D5329; AASHTO T49, T187 and others

Direct-reading instrument for precision penetration measurements of bituminous materials, cement, petrolatum and waxes, as well as food, cosmetics and pharmaceutical products. Unit has 5" diameter indicator dial, graduated in 400 divisions of 0.1mm, corresponding to 40mm penetration. Zero preset to eliminate errors. Includes 47.5g plunger with 3.2mm hole, and two loading weights (50g and 100g). Overall dim. 10.5" x 13" x 22" (266.7 x 330.2 x 558.8mm).

Penetrometer, Universal **H-1200**
Shipping wt. 25 lbs (11kg)

Penetrometer, Electric

ASTM D5, D217, D1168, D1191, D1321, D1403, D1831, D1855; AASHTO T49, T187 and others

Takes our H-1200 universal penetrometer and adds an automatic digital timer to it. The timer's release mechanism is switchable between seconds minutes, or hours. Timer may be set in 1/10th second intervals. Plunger releases with push of a button, and automatically stops after the preset time duration. H-1240.4F adds a voltage adapter and internal switch on the timing mechanism to change cycle to 50Hz

Penetrometer, Electric, 120V 60Hz **H-1240**
Penetrometer, Electric, 220V 50/60Hz **H-1240.4F**
Shipping wt. 32 lbs (15kg)

Penetrometer, Digital

ASTM D5, D217, D1168, D1191, D1321, D1403, D1831, D1855; AASHTO T49, T187 and others

The H-1240D penetrometer adds a digital gauge to the H-1240 electric penetrometer to provide precise at-a-glance readings, as well as the ability to automatically start a test with a button push and have the test end after a preset duration.

Penetrometer, Digital, 120V 60Hz **H-1240D**
Penetrometer, Digital, 220V 50/60Hz **H-1240D.4F**
Shipping wt. 26.2 lbs (11.8kg)

Penetrometer for Battery Paste

Battery Paste Penetrometer combines the H-1200 and a H-1255 grease cone, which has a hardened steel tip with a special plunger. Total needle weight is 60g ±.050g.

Penetrometer for Battery Paste **H-1202**
Shipping wt. 25 lbs (11kg)

Penetrometer, Portable

ASTM D5, D217, D1168, D1191, D1321, D1403, D1831, D1855; AASHTO T49, T187 and others

Lighter and smaller than H-1200 for field work, unit's micrometer adjusts for accurate settings, as well as coarse adjustment for approximate settings. Only one additional 50g loading weight is included with a H-1280 needle. Overall dim. 7" x 7" x 16" (178 x 178 x 406mm).

Penetrometer, Portable **H-1250**
Shipping wt. 14 lbs (6.3kg)

Penetrometer for Battery Paste, Portable

Battery Paste Penetrometer combines the H-1250 and a H-1255 grease cone, which has a hardened steel tip with a special plunger. Total needle weight is 60g ±.050g.

Penetrometer for Battery Paste, Portable **H-1252**
Shipping wt. 9 lbs (4.08kg)

Deluxe Water Bath

ASTM D6927, D5581 and D4867

Microprocessor-based control for precise temperatures throughout the range to 180°F. Includes magnetic circulator, ensuring constant water temperature, and, a stainless steel shelf, which stands 2" (51mm) above the bottom of the unit for free circulation of water above and below test samples aided by magnetic stir bar, included. Volume is 7.76 gallons (29.40L) and dimensions are: ID: 19.5" W x 11.5" D x 8" H (495.3 x 292.1 x 203.2mm)

Deluxe Water Bath, 120V 60Hz **H-1390**
Deluxe Water Bath, 220V 50/60Hz **H-1390.4F**
Shipping wt. 44lbs. (19.9kg)

Water Bath

ASTM D6927, D5581 and D4867

Microprocessor-based control for precise temperatures throughout the range. Includes a stainless steel shelf, which stands 2" (51mm) above the bottom of the unit for free circulation of water above and below test samples. Volume is 7.76 gallons (29.40L) and dimensions are: ID: 19.5" W x 11.5" D x 8" H (495.3 x 292.1 x 203.2mm).

Deluxe Water Bath, 120V 60Hz **H-1392**
Deluxe Water Bath, 220V 50/60Hz **H-1392.4F**
Ship wt. 43lbs. (19.5kg)

Economy Water Bath

Low-cost alternative water bath for heating specimens holds eight standard 4" stability molds. Supporting shelf above the bottom allows water circulation around specimens. Automatic thermostatic control with a range of 150° to 500°F (65° to 160°C). ID 11.5" x 19.5" x 5.5" (293 x 497 x 140mm) deep. H-1380.4F uses a step-down transformer, which is included, for electric conversion.

Deluxe Water Bath, 120V 60Hz **H-1380**
Deluxe Water Bath, 220V 50/60Hz **H-1380.4F**
Ship wt. 18lbs. (8.16kg)

Transfer Dish

ASTM D5

Plastic transfer dish has flat bottom, straight sides and metal centering lugs with magnet in the bottom. Size is: 3.75" dia. x 3.25" deep (95 x 83mm).

Transfer Dish **H-1352**
Shipping wt. 0.9 lb (0.4kg)



H-1392



H-1352

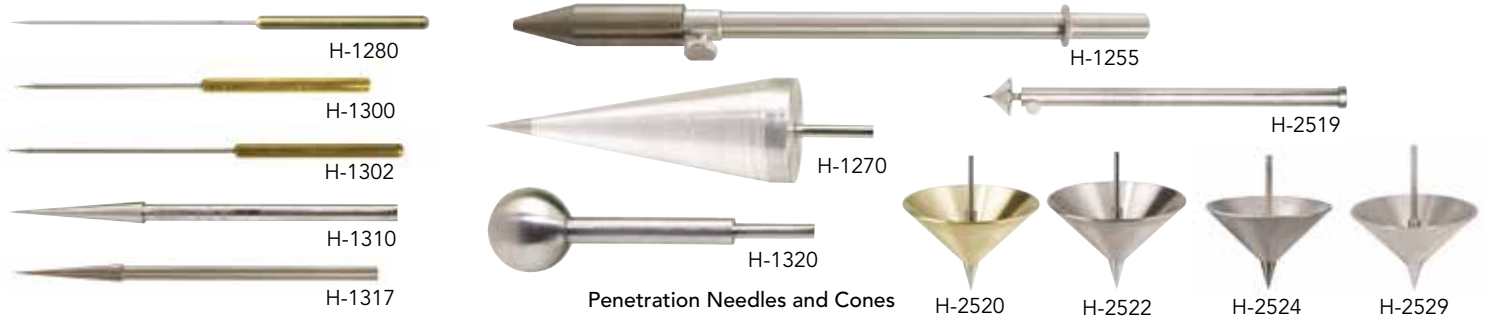

Material	Tool Description	Model	Tool Description	Model
Bituminous materials ASTM D5; AAS- HTO T49, IP49; ASA Std. A37.1; Fed Spec. SS.R. 406C, Meth. 214.01	Standard hardened stainless steel needle, 40-45mm exposed needle length. Wt. 2.5g.	H-1280	Measuring firmness of solid and plasticized fats: shortenings, butters AOCs Cc 16-60	H-1270
	Standard hardened stainless steel needle, 40-45mm exposed needle length. Certified to ASTM accuracy by independent laboratory. Wt. 2.5g.	H-1300	Recovery of used grease, small samples ASTM D1403	H-2519
	Long hardened stainless steel needle, 50-55mm exposed needle length. Wt. 2.5g.	H-1290	Grease testing penetrometers ASTM D217, D937 ASA Std. Z11.3	H-2520
	Long hardened stainless steel needle, 50-55mm exposed needle length. Certified to ASTM accuracy by independent laboratory. Wt. 2.5g.	H-1302	ASTM D2884	H-2524
Waxes with 250 or less penetration ASTM D1321	Hardened stainless steel wax penetration needles with tapered point, blunt tip of truncated cone. Ferrule is approx. 3.2mm dia. Wt. 2.5g.	H-1310	Food, Paste, Paints U.S. Dept of Agriculture	H-2529
	Same as H-1310. Certified to ASTM accuracy.	H-1317	Applications requiring 90° cones, ASTM D217, D937 ASA std. Z11.3	H-2525
Battery paste	Hardened stainless steel tip with special plunger. Total wt. 60g ± .050g.	H-1255		
Joint sealant for asphalt & concrete pavements ASTM D5329	Resilience ball penetration tool. Total wt. 27.5g.	H-1320		

Aluminum Moisture Boxes

Flat-bottom, straight-side seamless aluminum box has tight fitting cover, which fits bottom of box as well. Protects sample from exposure during storage and weighing operations.

Aluminum Moisture Boxes See chart below

Sample Cups, Tin

Flat-bottom, seamless tin sample cups have telescoping covers. Hold samples for determining penetrations.

Sample Cups, Tin See chart to right

Sample Cups, Tin

Capacity	Dimensions	Quantity	Model
2.5 oz (71g)	1.87" (47.5mm) ID, 1.42" (36mm) deep	48	H-1350.3A
3 oz (85g)	2.25" (57.1mm) ID, 1.42" (36mm) deep	36	H-1350.3
4.7 oz (133g)	2.42" (61.5mm) ID, 1.67" (42.6mm) deep	36	H-1350.4A
5.6 oz (159g)	2.59" (66mm) ID, 1.72" (43.4mm) deep	36	H-1350.6A
8.2 oz (232g)	3.05" (77.5mm) ID, 1.97" (50mm) deep	18	H-1350.8A
16 oz (454g)	4" (102mm) ID, 2.375" (60.3mm) deep	1	H-1350.16
42.3 oz (1200g)	6.12" (155mm) ID, 3" (76.2mm) deep	1	H-1350.42
70.5 oz (2000g)	6.12" (155mm) ID, 5" (127mm) deep	1	H-1350.70

Moisture Boxes, Aluminum

OD	ID	Height	Inside Ht.	Volume cu. in./fl. oz.	Model
2" (51mm)	1.975 (50mm)	.875" (22mm)	0.865" (22mm)	2.650 (44cc) 1.47 (44ml)	H-4926
2.5" (64mm)	2.470 (63mm)	1.75" (44mm)	1.746" (44mm)	8.366 (137cc) 4.64 (137ml)	H-4927
3" (76mm)	3.000 (76mm)	1" (25mm)	0.985" (25mm)	6.963 (114cc) 3.86 (114ml)	H-4928
3.5" (89mm)	3.490 (89mm)	2" (51mm)	1.990" (51mm)	19.037 (312cc) 10.55 (312ml)	H-4929





Viscometer and Thermosphere sold separately

Digital Rotational Viscometer

ASTM D4402; AASHTO T316

The H-1638, Fungilab Evo Expert R range rotational viscometer paired with the Asphalt Industry Thermosphere offers the latest in SHRP asphalt binder testing equipment specifically designed to meet the requirements of ASTM D4402 / AASHTO T316 high-temperature test methods for asphalt binders. The precision and accuracy for controlling sample temperatures up to +300°C is ideal for the asphalt industry.

The H-1638 viscometer provides a measuring range of 25-40,000,000 cP with 54 speeds in a range from 0.01 to 200 rpm. A Color TFT screen, for easy reading and fast data recognition is paired with an intuitive, full-touch key pad provides the ultimate in data control. The Evo Expert also provides USB connection to your PC and WiFi integration for easy control and access to your measurements. It also includes DataBoss software.

Features:

- Data displayed:
 - Selected speed: rpm
 - Selected spindle: SP
 - Viscosity reading: P mPas or cSt
 - Percentage of full scale: %
 - Sample temperature: °C or °F
 - Shear Rate: SR (s-1) with coaxial spindles
 - Shear Stress: SS N/m² (with coaxial spindles)
 - Density: g/cm³
- Viscosity reading: dynamic viscosity, cP or mPa·s, or kinematics viscosity, cSt.
- Unit converter: SI to CGS.

Program Features:

- Time to torque & Time to stop
- 9 working memories
- Customizable speed options
- Multi-step
- Ramp
- AUTO-TEST: automatical internal viscosimeter checking
- AUTO-RANGE: full scale range for combination spindle speed.
- Temperature reading by PT100.
- User-enabled viscosity and temperature calibration.
- 10 language options.

The Viscometer includes: Viscometer head with serial number, stand with 3-point levelling adjustment, Boss head, (1) TR8 spindle, spindle protector, spindle rack, PT100 probe, Datalogger software, USB cable, power cable, carrying case and calibration certificate.

Rotational Viscometer, 100/240V 50/60Hz H-1638.3F



Shipping wt. 18.0lbs (8.16kg)

Thermosphere

ASTM D4402; AASHTO T316

The Thermosphere allows for measurement of accurate viscosities at elevated temperatures. It offers the precision and accuracy for controlling sample temperature up to +300°C, ideal for the asphalt industry. It synchronizes with the Evo Expert Rheometer, above, to provide viscosity data. It provides an accuracy of 0.5°C for ambient to 80°C, <1.0°C for 80 to 150°C and <1.5°C for 150 to 300°C. Samples are placed in disposable Thermosphere chambers for each test. These chambers are available in 50 and 100 packs.

The Thermosphere includes: Thermosphere chamber; 3 height adjustable knobs for the base; Chamber; Chamber lid; Chamber support; Tweezer; Power cable; Holding rod enlarger for viscometer and an adapter to connect viscometer and thermosphere.

Thermosphere, 100V 60Hz

H-1639

Thermosphere, 220V 50/60Hz

H-1639.4F



22.0lbs (10.0kg)

Viscometer/Rheometer Accessories and Parts

Description	Model
Thermosphere chambers, 100pk.	H-1639.1
Thermosphere chambers, 50pk.	H-1639.2
Spindle (TR8) 50-170,000CP	H-1638.1
Spindle (TR9) 250-830,000CP	H-1638.2
Spindle (TR10) 500-170,000CP	H-1638.3
Spindle (TR11) 1000-3,300,000CP	H-1638.4
Silicone Std. Oil, RT 30,000 (600ml)	H-1637.6
Silicone Std. Oil, RT 60,000 (600ml)	H-1637.7
Silicone Std. Oil, RT 100,000 (600ml)	H-1637.8





H-1720



H-1730



H-1741H

H-1741V

Constant Temperature Bath, 100°C

ASTM D445

Specifically designed for precise viscosity determination with glass capillary viscometers, the H-1720 baths offer superior temperature control to 100°C. The H-1720 offers a 12" Dia x 12" H (305mm x 305mm). bath jar that can accommodate most viscometers.

These baths maintain accurate temperature control of ± 0.01°C within the range of 20°C to 100°C (±0.01°C), providing the temperature sensitivity required by ASTM D445 for kinematic viscosity measurements with glass capillary viscometers. Two electric heating elements inside the bath rapidly heat the medium to any desired temperature within the range.

The H-1720 bath chamber is a cylindrical clear glass vessel 12" dia x 12"H (305mm x 305mm). A stainless steel baffle located in the center of the bath provides a plain reflective background to aid in viewing instruments. The top cover contains seven round holes 2" (51mm) in diameter for insertion of viscometer holders, allowing up to seven viscosity measurements to be made simultaneously. Covers are supplied for capping unused holes. Two additional holes 10mm in diameter, are provided for thermometers. All wetted parts of the Constant Temperature Bath are made of stainless steel or glass. The frame is fabricated from heavy aluminum and coated with a corrosion-resistant epoxy finish. **Viscometers, holders, bath oil, and thermometers must be purchased separately.** Dimensions: 16"w x 14.25"d x 24"h (407 x 362 x 610mm).

Constant Temp. Bath, 120V 60Hz H-1720

Constant Temp. Bath, 220V 50/60Hz H-1720.4F

Shipping wt. 80 lbs (36.2kg)



Constant Temperature Bath, 150°C

ASTM D445

The H-1730 constant temperature bath maintains the accurate control required by ASTM D445 for kinematic viscosity measurements with glass capillary viscometers. The H-1730 baths offer superior temperature control to 150°C. Within the range of 20 to 100°C, temperature is controlled to 0.01°C; above 100°C temperature it is controlled to 0.03°C.

The H-1730 bath chamber is a cylindrical clear glass vessel 12" dia x 12"H (305mm x 305mm). A stainless steel baffle is located in the center of the bath to provide a good background for viewing viscometers. Two fluorescent lamps illuminate the interior of the bath brightly and uniformly, without glare. Two heating elements inside the bath rapidly heat the bath medium to any temperature within the bath range. The top cover contains seven round holes 2" (51mm) in diameter. Up to seven glass capillary viscometers (in holders) can be placed in the bath. Other hole configurations can be supplied on special order.

A solid-state control circuit, equipped with a stainless steel-encased thermistor provides proportional control of temperature. A motor-driven stirrer ensures a uniform temperature throughout the bath.

All wetted parts of the bath are made of stainless steel or glass. The bath housing is fabricated from heavy aluminum and coated with a corrosion-resistant epoxy finish. **Viscometers, holders, bath oil, and thermometers must be purchased separately.** Dimensions: 17.25"w x 18.25"d x 23"h (438 x 464 x 584mm).

Constant Temp. Bath, 120V 60Hz H-1730

Constant Temp. Bath, 220V 50/60Hz H-1730.4F

Shipping wt. 123 lbs (56kg)



Digital Vacuum Pressure Regulators

ASTM D2171

These digital vacuum regulators (DVR) are designed for precise measurement and control of vacuum at 300 mm Hg below atmospheric pressure. Unlike other vacuum regulators, the solid-state H-1741H and H-1741V Regulators use no mercury. Both units are identical except that one is a horizontal configuration and the other is vertical.

DVR meters display the amount of vacuum in mm/Hg or one of nine other units of measurement selected using a keypad on the meter.

In asphalt laboratories the digital vacuum regulator (DVR) may be used in conjunction with Cannon-Manning, Asphalt Institute, and Modified Koppers vacuum viscometers for measurement of highly viscous materials such as asphalt cement at 60°C (140°F) according to ASTM D 2171. The DVR is also useful in other laboratory systems where accurate measurement and control of vacuum is required.

Both the H-1741H and H-1741V are equipped with an internal vacuum pump and do not require an external vacuum source.

The internal set points for the instrument gauge are preset to regulate vacuum at 300 ± 0.5 mm Hg below atmospheric pressure (the vacuum required by ASTM D 2171). These set points may be altered to fit the user's specific needs within the DVR's operating range of 28 to 410 mm Hg below atmospheric pressure.

Reading accuracy: ±0.5mm HG. Operating temperature: 0 to 40°C (32 to 104°F). Upper/lower safety limit: 746mm HG below atmospheric pressure. Choice of horizontal: 18.5"w x 18"d x 6.75"h (470 x 457 x 171mm) or vertical: 6.75"w x 18" d x 18.5"h (171 x 457 x 470mm).

Digital, Vacuum Pressure Regulator

Regulator, Horizontal, 120V 60Hz H-1741H

Regulator, Horizontal, 220V 50/60Hz H-1741H.4F

Regulator, Vertical, 120V 60Hz H-1741V

Regulator, Vertical, 220V 50/60Hz H-1741V.4F

Shipping wt. 30 lbs (13.6kg)





H-1733



H-1745
H-1735



H-1722



H-1746.7



H-1747.1

IBF Bath Oil

Oil for constant temperature baths operating at less than 135°C (275°F). 6-gallon container (2.3L)

UBF Bath Oil H-1732

Shipping wt. 50 lbs (22.6kg)

Bath Fluid, High-Temperature Silicone

This clear, colorless, oily liquid has a nominal viscosity of 50 centistokes at 25°C, with a viscosity/temperature coefficient of 0.59. The boiling point is over 360°C with a flash point above 535°F. Fluid has a maximum volatility, with 0.5% weight loss over 24 hours at 150°C.

Bath Fluid, Silicone, .5 Gallon H-1733

Shipping wt. 20 lbs (9.07kg)

Vacuum Manifold

Vacuum manifold with manual valves for applying vacuum or pressure to capillary-type viscometers. Designed for use with the H-1720 and H-1730 constant temperature baths. Integral brackets permit mounting on bath covers. Two models are available: one for the H-1730, which has four valves and one for the H-1720, which has three valves. Both include a 10-foot length of rubber vacuum tubing, .25" bore x .625 OD, for connection to vacuum/pressure regulators. Housing is epoxy-coated aluminum, overall 13"W x 2.75"D x 9"H (330 x 70 x 229mm)

Vacuum Manifold for H-1720 H-1745

Vacuum Manifold for H-1730 H-1735

Shipping wt. 6 lbs (2.7kg)

Temperature Bath Storage Pedestal

This Heavy-duty, two-drawer unit provides a pedestal for constant temperature baths, as well as storage of accessories and consumables. It provides elevated viewing of the bath and ample room for storage of viscometers and other accessories. **Dimensions:** 18" W x 18" D x 6.5" H (457 x 457 x 165mm)

Temperature Bath Storage Pedestal H-1722

Shipping wt. 40 lbs (18.1kg)

Zeitfuchs® Cross-Arm Viscometer and Holder

ASTM D445, D446, D2170; AASHTO T201; ISO 3105

These models are used to determine kinematic viscosity of liquid asphalts, road oils and distillation residues of liquid asphalts at 140°F (60°C) and of asphalt cements at 275°F (135°C), requiring a charge of only 1 to 3ml. They are easily filled and cleaned while immersed in a temperature bath and need not be removed. The viscometers require a liquid depth of 9" (229mm). Includes round metal holder for 2" (51mm) dia. hole and certificate of calibration.

Zeitfuchs® Cross-Arm Viscometer see chart below

Shipping wt. 2 lbs (.9kg)

Zeitfuchs® Cross-Arm Viscometer and Holder

Size	Approx. Constant Cs/Sec.	Range of Centistokes	Model
1	0.003	0.6 to 3	H-1746.1
2	0.01	2 to 10	H-1746.2
3	0.03	6 to 30	H-1746.3
4	0.1	20 to 100	H-1746.4
5	0.3	60 to 300	H-1746.5
6	1.0	200 to 1,000	H-1746.6
7	3.0	600 to 3,000	H-1746.7
8	10	2,000 to 10,000	H-1746.8
9	30	6,000 to 30,000	H-1746.9
10	100	20,000 to 100,000	H-1746.10

Asphalt Institute Vacuum Viscometer

ASTM D2170, D2171

Designed for measurement of highly-viscous materials, such as asphalt cement at 60°C (140°F), viscometer contains a graduated capillary instead of timing bulbs. Applicable to materials with a viscosity range of 0.036 to 80,000 poise. They require a minimum sample volume of only 3ml and require a liquid bath depth of 180 mm (7.1 inches). Includes permanently-attached, round metal holder for 2" (51mm) dia. hole and certificate of calibration.

Asphalt Inst. Vacuum Viscometer see chart below

Shipping wt. 2 lbs (.9kg)

Asphalt Institute Vacuum Viscometers

Size/No.	Viscosity Range (Poise)	Approx. Constant poise/second at 300mm Hg Vacuum			Model
		B	C	D	
25	42 to 800	2	1	0.7	H-1747.1
50	180 to 3,200	8	4	3	H-1747.2
100	600 to 12,800	32	16	10	H-1747.3
200	2,400 to 52,000	128	64	40	H-1747.4
400R	9,600 to 140,000	500	250	160	H-1747.5
800R	38,000 to 5,800,000	2000	1000	640	H-1747.6



H-2165



H-2166A



H-2167

H-2166A shown with (4) Automatic Timers, which need to be ordered in addition to the H-2166A bath, see below.

Saybolt Viscosity Bath

ASTM D88, D244, E102; AASHTO T72

Designed for Saybolt universal and furlol viscosity testing, this constant temperature bath meets all ASTM and AASHTO requirements for precise temperature control. The micro-processor PID circuitry assures accurate temperature control within ASTM tolerances throughout the range of ambient to 464°F (240°C). Temperature stability is $\pm 0.05^\circ\text{F}$ ($\pm 0.03^\circ\text{C}$)

Simple push-button controls and dual digital displays are used for easy setting and monitoring of the baths temperature. With a capacity of four viscometers and 60ml receiving flasks, the bath features sliding draft shields, chemical-resistant alignment plates for handling of flasks and a glare-free fluorescent backlight for easy viewing of test sample. The insulated bath interior is constructed entirely of heavy-gage stainless steel and the built-in overflow pipe and drain valve simplifies filling the bath oil to the required level. A chemical resistant top plate provides insulation and is easily removed to allow for cleaning of the bath interior. The bath is supplied complete with four thermometer supports, four port covers, four chained corks, two port closures, tube nut wrench, orifice wrench, withdrawal tube and oil strainer. Viscometer tubes, orifices, receiving flasks, oil and thermometers are not included and must be ordered separately.

Saybolt Bath, 120V 60Hz H-2165
 Saybolt Bath, 220-240V 50/60Hz H-2165.4F
 Shipping wt. 100 lbs (45.3kg)

Saybolt Viscosity Bath, For Automatic Timers

ASTM D88, D244, E102; AASHTO T72

Constant temperature viscosity bath designed for use with one to four Automatic Saybolt Viscosity Timing Sensors. **Bath is sold with no timers, order auto timers separately.** Features simple push-button controls and dual digital displays are used for easy setting and monitoring of the baths temperature.

With a capacity of four viscometers and 60ml receiving flasks, the bath features sliding draft shields, chemical-resistant alignment plates for handling of flasks and a glare-free fluorescent backlight for easy viewing of test sample. The insulated bath interior is constructed entirely of heavy-gage stainless steel and the built-in overflow pipe and drain valve simplifies filling the bath oil to the required level. A chemical resistant top plate provides insulation and is easily removed to allow for cleaning of the bath interior. A cooling coil for tap water or refrigerated coolant is provided for operation at near-ambient temperatures. Steel cabinet has leveling feet and a chemical-resistant polyurethane-epoxy finish.

Temperature range is ambient to 464°F (240°C) and temperature stability is $\pm 0.05^\circ\text{F}$ ($\pm 0.03^\circ\text{C}$). Bath capacity is 5 gallons (19L) and recommended bath medium is water or suitable heat transfer fluid. Included accessories: Cleaning plunger; chained corks; oil strainer; withdrawal tube; tube nut wrench; orifice wrench; port closures; port covers and thermometer supports.

Saybolt Viscosity Bath, 120V 60Hz H-2166A
 Saybolt Viscosity Bath, 220-240V 50/60Hz H-2166A.4F
 Shipping wt. 82 lbs (37kg)

Automatic Timers for Saybolt Viscosity Bath

ASTM D88, D244, E102; AASHTO T72

At the push of a button, the automatic timer starts the sample flow, senses the 60ml end point and digitally records and displays the efflux time in 0.1 seconds resolution with an accuracy of 0.05%. Automatic timing improves testing accuracy and convenience, eliminating the chain and cork assembly and the need to manually time each sample. One to four automatic timers can be fitted to the H-2166A Saybolt viscosity bath.

Saybolt Viscosity Timing Sensor, 120V 60Hz H-2167
 Saybolt Viscosity Timing Sensor, 220-240V 50/60Hz H-2167.4F

Shipping wt. 5 lbs (2.2kg)



CAUTION These thermometers contain mercury. There are restrictions on their sale and shipment. Please check laws in your area or contact us before ordering. Due to Illinois law, Humboldt must drop-ship these items from New Jersey. Mercury Thermometers require ground shipment in the U.S. Not sold outside United States.

Test Apparatus Setup for bituminous materials

Description	Qty.	Model #
Saybolt viscometer bath	1	H-2165 H-2165.4F H-2166A H-2166A.4F
Viscometer tube	4	H-2180
Furol orifice	4	H-2174
Displacement ring	4	H-2194
Receiving flask for H-2165 or Borosilicate flask for H-2166	4	H-2176
Technical oil, white	5	H-2189
ASTM Thermometer*	1	H-2600.17F
or ASTM Thermometer*	1	H-2600.17C

Test Apparatus Setup for lubricants, insulating oils and heater fuels

Description	Qty.	Model #
Saybolt viscometer bath	1	H-2165 H-2165.4F H-2166A H-2166A.4F
Viscometer tube	4	H-2180
Universal orifice	4	H-2173
Receiving flask for H-2165 or Borosilicate flask for H-2166	4	H-2176
Technical oil, white	5	H-2189
ASTM thermometer*	1	H-2600.17F
or ASTM thermometer*	1	H-2600.17C

Saybolt Viscosity Bath Accessories

Description	Model
Cleaning plunger	H-2175
Borosilicate glass receiving flask, 60ml (for H-2165)	H-2176
Borosilicate glass receiving flask, 60ml (for H-2166)	H-2179
Withdrawal tube	H-2177
Oil strainer	H-2178
Technical oil, white, (1 gal.) suitable for use up to 230°F (110°C)	H-2189
High-temp. Dow-Corning 200 fluid (100 centistokes), 5 gallon, wt.40lb (18kg)	H-2199
Displacement ring	H-2194
Thermometer support	H-2195
Orifice wrench	H-2196
Socket wrench	H-2197
Thermometer* (66 to 80°F)	H-2600.17F
Thermometer* (19 to 27°C)	H-2610.17C
Thermometer* (94 to 108°F)	H-2600.18F
Thermometer* (34 to 42°C)	H-2610.18C
Thermometer* (120 to 134°F)	H-2600.19F
Thermometer* (49 to 57°C)	H-2610.19C
Thermometer* (134 to 148°F)	H-2600.20F
Thermometer* (57 to 65°C)	H-2610.20C
Thermometer* (174 to 188°F)	H-2600.21F
Thermometer* (79 to 87°C)	H-2610.21C
Thermometer* (204 to 218°F)	H-2600.22F
Thermometer* (95 to 103°C)	H-2610.22C

Components

Description	Model
Tubes with Orifices	
Brass saybolt viscometer tube w/ stainless steel universal orifice	H-2180
Brass saybolt viscometer tube w/stainless steel furol orifice	H-2182
Stainless saybolt viscometer Tube w/stainless steel furol orifice	H-2183
Brass saybolt viscometer tube w/stainless steel universal and furol orifice, includes wrench	H-2184
Stainless saybolt viscometer tube w/ universal and furol orifice, includes wrench	H-2185
Orifices	
Stainless steel universal	H-2173
Stainless steel furol	H-2174
Stainless steel furol, calibrated	H-2174C
Tubes	
Stainless steel saybolt viscometer tube	H-2171
Brass saybolt viscometer tube	H-2172





Ford Viscosity Cups

ASTM D333, D365, D1200

Used in determining viscosity of paint, lacquers and related coatings. Cup body is machined from aluminum; orifice is brass. Orifice not included with H-1530 cup, order from chart below. Cup/Orifice combinations should be selected to provide an efflux time within the 20 to 100-second range. Measurements with the Ford viscosity cup should be made at a temperature of 25°C ±0.1° (77°F ±0.2°) with a H-2610.17C (or H-2600.17F) thermometer. **Order thermometers and stand separately.**

Ford Cup w/ No. 1 Orifice	H-1530.1
Ford Cup w/ No. 2 Orifice	H-1530.2
Ford Cup w/ No. 3 Orifice	H-1530.3
Ford Cup w/ No. 4 Orifice	H-1530.4
Ford Cup w/ No. 5 Orifice	H-1530.5

Shipping wt. 1.2 lb (0.5kg)

Viscosity Cup Stand

Features leveling base and adjustable support bracket for H-1530 Ford viscosity cup.

Viscosity Cup Stand	H-1535
---------------------	--------

Shipping wt. 5 lbs (2.3kg)

Asphalt Viscosimeter Float Test Set

ASTM D139, AASHTO T50

Used to test flow behavior or consistency of certain bituminous materials and tar products via a float test. Includes calibrated aluminum float and three brass collars. Individual components can be ordered. **Order thermometer separately.**

Asphalt Viscosimeter Float Test Set	H-1400
-------------------------------------	--------

Shipping wt. 0.6 lb (0.27kg)

Float Test Set Components

Description	Model
Float only	H-1410
Collars only (set of three)	H-1420

Cloud and Pour Point Apparatus Set

ASTM D97, D117, D2500

Used to test flow characteristics of petroleum oils using cloud and pour points. Includes glass bath jar, polished brass cylinder mounted on metal tripod base, glass test cylinder, cork bottom disc and top rings. **Order thermometer separately.**

Cloud and Pour Point Apparatus Set	H-2560
------------------------------------	--------

Shipping wt. 5.3 lb (2.4kg)

Cloud and Pour Components

Description	Model
Metal tripod base	H-2560.1
Glass test jar	H-2560.3
Glass battery bath jar	H-2560.5
Brass cylinder	H-2560.2
Cork disks	H-2595
Cork rings	H-2598
Thermometer* -36 to 120°F	H-2600.5F
Thermometer* -38 to 50°C	H-2610.5C
Thermometer* -112 to 70°F	H-2600.6F
Thermometer* -80 to 20°C	H-2610.6C

Spot Test of Asphaltic Materials Set

AASHTO T102

Spot test set only for asphaltic products derived from petroleum not to be used for natural asphalts containing non-bituminous matter insoluble in xylene. Includes 250ml erlenmeyer flask, filter paper, 10ml pipette and rubber stopper.

Spot Test of Asphaltic Materials Set	H-1510
--------------------------------------	--------

Shipping wt. 3 lb (1.3kg)



CAUTION These thermometers contain mercury. There are restrictions on their sale and shipment. Please check laws in your area or contact us before ordering. Due to Illinois law, Humboldt must drop-ship these items from New Jersey. Mercury Thermometers require ground shipment in the U.S. Not sold outside United States.

Digital, Auto Ring and Ball Apparatus

ASTM D36; AASHTO T53; EN 1427; BIS 2000; DIN 52011; UNE 7111

Designed for speed and accuracy, this ring and ball apparatus automatically determines the softening point of asphalts and pitches. Two laser sensors detect the fall of the ball, detecting and recording the softening point of the test material.

Touch-screen graphical interface allows for easy setup of the parameters and the immediate execution of the test. The high-resolution color display offers all functions of a PC for the management and analysis of data, test results and graphs. Bath temperature is measured by an electronic system maintaining the gradient (5°C/min) as specified by the standard. Provides real-time visualization of the temperature/time graph for the entire test. A magnetic stirrer with electronic speed adjustment from 0 to 160rpm also ensures a uniform temperature in the vessel during the complete test.

Unit provides the ability to test with boiled distilled water for softening points from 30 to 80°C and 80° up to 150°C using glycerol.

Export data to a PC via USB flash drive or SD card with the ability to edit the data easily with Excel. Multiple languages are built in.

Digital, Auto Ring and Ball Apparatus	H-1567.4F
---------------------------------------	-----------

Shipping wt. 66 lb (30kg)

Description	Model
Steel ball, 9.5mm dia.	H-1567.1
Brass, tapered ring, chromed	H-1567.2
Centering guide, chromed-brass	H-1567.3
Beaker, 600ml pyrex	H-4911.600
Calibration rods (2)	H-1567.4





H-1569



H-1570

Softening Point Apparatus, Double
ASTM E28; AASHTO T53

Ring and ball method Apparatus for softening point determinations for use with asphalts, pitches, tars and most resins. Includes 800ml beaker with brass, double set-up fixture with cover and thermometer port with stopper, 2 shouldered rings, 2 ball centering guides and 2 standard balls. Order required thermometer separately.

Softening Point Apparatus, Double H-1569
Shipping wt. 2lbs (.9kg)

Softening Point Apparatus, Quad

Ring and ball method Apparatus for softening point determinations for use with asphalts, pitches, tars and most resins. Includes 800ml beaker with brass, quad set-up fixture with cover and thermometer port with stopper, 4 shouldered rings, 4 ball centering guides and 4 standard balls. Order required thermometer separately.

Softening Point Apparatus, Quad H-1570
Shipping wt. 2lbs (.9kg)

Softening Point Apparatus Set w/ Burner

Single, ring and ball method softening point apparatus set, including burner. This set can be used for single determinations such as: asphalts, pitches, tars and most resins. Includes burner, beaker, support stand, 1 ring, wire gauze with ceramic center, thermometer clamp, 1 shouldered ring and stem with hardened steel ball. Order required thermometer separately.

Softening Point Apparatus Set w/Burner H-1595
Shipping wt. 10lbs (4.5kg)



H-1595

Shown with Thermometers, not included, order separately



H-1596

Softening Point Apparatus Set w/ Hotplate

Single ring and ball method softening point apparatus set, including hotplate. This set can be used for single determinations such as: asphalts, pitches, tars and most resins. Includes 6" x 6" electric hotplate as a heat source rather than a gas burner. The hotplate provides an easy-to-set analog temperature control knob with graduated scale and LED display. Temperature range is: ambient to 540°C (Ambient to 1004°F). Includes beaker, support stand, 1 ring, wire gauze with ceramic center, thermometer clamp, 1 shouldered ring and stem with hardened steel ball. Order required thermometer separately.

Softening Point Apparatus Set w/Hotplate H-1596
120V 60Hz
220V 50/60Hz
Shipping wt. 18.4lbs (8.3kg)and

Thermometers* for Softening Point Apparatus

Description	Model
30 to 180°F (ASTM 15F)	H-2600.15F
-2 to 80°C (ASTM 15C)	H-2610.15C
85 to 392°F (ASTM 16F)	H-2600.16F
30 to 200°C (ASTM 16C)	H-2610.16C
30 to 350°F (ASTM 113F)	H-2600.113F
-1 to 175°C (ASTM 113C)	H-2610.113C



CAUTION These thermometers contain mercury. There are restrictions on their sale and shipment. Please check laws in your area or contact us before ordering. Due to Illinois law, Humboldt must drop-ship these items from New Jersey. Mercury Thermometers require ground shipment in the U.S. Not sold outside United States.



H-1575



H-1580



H-8900



H-8980

Description	Model
Brass, shouldered ring, Top: 23mm OD, 19.8mm ID; Bottom: 19mm OD, 15.9mm ID; Top to Shoulder: 4.4mm High; Shoulder to Bottom: 2mm High, 10 per package	H-1575
Hardened steel ball, .375" 99.5mm) dia.; weight between 3.45 and 3.55g, 10 per package	H-1580
Ball centering guide for shouldered rings, ball is centered on specimen by 3 locator pins	H-1588
Ring and stem assembly with 16" (406mm) long brass wire stem with shouldered brass ring	H-1602
Steel, clamp hook supports suspended thermometers. Locks into any position with check nut, Maximum distance from center of muff to hook: 4.25" (108mm), minimum distance is: 3.875" (99mm)	H-8900
Thermometer clamp with adjustable 360° muff, phosphor-bronze jaws, 3.5" (89mm) long	H-8950
Thermometer clamp, similar to H-8950, but holds H-1602 ring and stem and thermometer together	H-8980
Base (Cast iron) w/ Support Rod	H-21220
Burner	H-6220
Beaker, 800ml, Graduated	H-4911.800
Hot plate, 6" x 6" with LED Display	H-4942
Wire Gauze, 5" x 5" w/ceramic material center	H-25865





H-2405B



H-2405S



H-2407B



H-2400



H-1990A



H-2495

Bacon Bomb Samplers, 8oz. (237ml)

ASTM D4057, D6074, D1265

Bacon Bomb Samplers can be used to obtain samples from storage tanks, tank cars and drums. when the sampler is lowered into the tank and hits the bottom, a plunger assembly opens to admit the material. The plunger closes again when the bomb is withdrawn, forming a tight seal. Equipped with plunger locking cam for tight closure during transport. Available in plated brass or stainless steel. 2" dia. x 10" L. (51 x 254mm).

- Bacon Bomb Sampler, 8oz, Brass H-2405B
- Bacon Bomb Sampler, 8oz, Stainless H-2405S

Shipping wt. 4lbs (1.8kg)

Bacon Bomb Samplers, 16oz. (473ml)

ASTM D4057, D6074, D1265

Bacon Bomb Samplers can be used to obtain samples from storage tanks, tank cars and drums. when the sampler is lowered into the tank and hits the bottom, a plunger assembly opens to admit the material. The plunger closes again when the bomb is withdrawn, forming a tight seal. Equipped with plunger locking cam for tight closure during transport. Available in plated brass or stainless steel. 2.75" dia. x 12" L (70 x 305mm).

- Bacon Bomb Sampler, 16oz, Brass H-2406B
- Bacon Bomb Sampler, 16oz, Stainless H-2406S

Shipping wt. 6lbs (2.7kg)

Bacon Bomb Samplers, 32oz. (946ml)

ASTM D4057, D6074, D1265

Bacon Bomb Samplers can be used to obtain samples from storage tanks, tank cars and drums. when the sampler is lowered into the tank and hits the bottom, a plunger assembly opens to admit the material. The plunger closes again when the bomb is withdrawn, forming a tight seal.

Equipped with plunger locking cam for tight closure during transport. Available in plated brass or stainless steel. 2.75" dia. x 15.25" L. (70 x 387mm).

- Bacon Bomb Sampler, 32oz, Brass H-2407B
- Bacon Bomb Sampler, 32oz, Stainless H-2407S

Shipping wt. 8lbs (3.6kg)

Weighted Beaker

For beaker sampling from tank cars, tank trucks, shore tanks, ship and barge tanks. Copper construction with weighted bottom. Includes handle and chained cork. Takes all level samples, as well as running and outlet samples. Select .75" (19mm) opening for light crude oils, light lubricating oils, kerosenes, gasolines, transparent gas oils, diesel fuels and distillates. Select 1.5" (38mm) for heavy crude and fuel oils, heavy lubricating oils and nontransparent gas oils. Body is 3.375" dia. x 14" L. (86 x 356mm).

- Weighted Beaker, .75" (19mm) H-2400
- Weighted Beaker, 1.5" (38mm) H-2401

Shipping wt. 5lbs (2.2kg)

Tag, Open-Cup Flash Tester

ASTM D1310, D3143; AASHTO T79

For determination flash and fire points of liquids at temperatures of up to 325°F (163 °C) and flash points of cutback asphalts at temperatures of less than 200°F (93 °C) as per test methods ASTM D1310, D3143 and related test specifications.

Determines Tag Open-Cup flash point of liquid products and cutback asphalts. Includes sample test cup, plated brass liquid bath with constant level overflow, pivoting ignition taper with pilot light and reference bead, pivoting thermometer holder, heater and base.

Electrically heated model is equipped with stepless variable heat control for accurate control of temperature rate of rise per specification. Gas heated model also available.

Includes Tag Open Cup Flash Point Tester, borosilicate glass sample cup, liquid bath with constant level overflow and manual. Order leveling device and draft shield separately. Order necessary ASTM 9C mercury thermometer locally. Illinois law prohibits us from selling mercury thermometers.

- Tag, Open-Cup Tester, 120V 60Hz H-1990A
- Tag, Open-Cup Tester, 230V 50/60Hz H-1990A.4F

Shipping wt. 37.1lbs (16.8kg)

Parts for Tag, Open-Cup Flash Tester

Description	Model
Replacement Pyrex cup	H-1990.1
Leveling device	H-1990.2
Thermometer, range: 20 to 230°F	H-2600.9F*
Thermometer, range: -5 to 110°C	H-2610.9C

Conradson Carbon Residue Apparatus

ASTM D189, D2416

Tests petroleum products to determine the amount of carbon residue left after evaporation and pyrolysis of an oil and to indicate relative coke-forming propensities. Includes burner, tripod, refractory block, nickel chrome triangle, nickel crucible and cover, Skidmore crucible, porcelain crucible and monel hood and bridge. Component parts available separately.

- Conradson Carbon Residue Apparatus H-2495

Shipping wt. 7.1lbs (3.2kg)

Parts for Conradson Apparatus

Description	Model
Porcelain crucible	H-2494
Skidmore crucible and cover	H-2497
Carbon residue apparatus hood	H-2496
Nickel crucible with cover	H-2498
Refractory block insulator ring	H-2505





H-2085

Cleveland Flash and Fire Point Tester

ASTM D92, D117; AASHTO T48

Used to determine flash and fire points by the Cleveland open-cup method. Consists of electric Heater with rheostat, flash point platform with Thermometer holder, test burner and flash cup. Utilizes a 1250W-10 amp, nickel-chromium heater with stepless variable control for accurate, repeatable, rate-of-rise temperature settings per specifications. Heater is enclosed in a stainless steel housing with cooling vents.

Thermometer position is adjustable and provides the ability to raise the thermometer out of the way to facilitate the placement and removal of the test cup. Test flame requires a gas supply and the test flame can be adjusted through the use of the built-in needle valve. Order thermometer separately.

Cleveland Flash Tester, 115V 60Hz H-2085
 Cleveland Flash Tester, 220V 50/60Hz H-2085.4F

Shipping wt. 14lbs (6.3kg)

Replacement Parts/Accessories

Description	Model
Electric heater with rheostat (1250W)	H-2085.1
Flash-point platform	H-2085P
Test burner w/ holder	H-2112
Flash cup	H-2060
Supra-board plate	H-2095.4.2
Thermometer*	H-2600.11F

CAUTION These thermometers contain mercury. There are restrictions on their sale and shipment. Please check laws in your area or contact us before ordering. Due to Illinois law, Humboldt must drop-ship these items from New Jersey. Mercury Thermometers require ground shipment in the U.S. Not sold outside United States.



H-2095

Cleveland Flash and Fire Point Tester

ASTM D92, D117; AASHTO T48

Used to determine flash and fire points by the Cleveland open-cup method. Consists of a Humboldt, high-temperature burner, which is directly attached to the test support stand, for sample heating with a built-in, gas line extension for the test flame. Test flame burner and the heating burner include separate, integral, adjustment controls for regulating the flame. Includes flash point platform with thermometer holder, test burner and flash cup.

Thermometer position is adjustable and provides the ability to raise the thermometer out of the way to facilitate the placement and removal of the test cup. Flame size is adjustable through the use of the built-in needle valve. Order thermometer separately.

Cleveland Flash Tester, Gas H-2095
 Shipping wt. 15lbs (6.8kg)

Replacement Parts/Accessories

Description	Model
Cast-Iron support base	H-21335
High-temp burner w/ adjustable valve orifice	H-5605X
Test burner w/ holder	H-2112
Flash-point platform	H-2095P
Supra-board plate	H-2095.4.2
Platform coupling assembly	H-2095.5
Flash cup	H-2060
Thumb screw	H-3050.7
Thermometer*	H-2600.11F



H-2100

Cleveland Flash and Fire Point Tester

ASTM D92, D117; AASHTO T48

Used to determine flash and fire points by the Cleveland open-cup method. Consists of a free-standing, Humboldt, high-temperature burner and a separate test flame burner, which is directly attached to the test support stand. Test flame burner and the heating burner include separate, integral, adjustment controls for regulating the flame. Includes flash point platform with Thermometer holder, test burner and flash cup.

Thermometer position is adjustable and provides the ability to raise the thermometer out of the way to facilitate the placement and removal of the test cup. Flame size is adjustable through the use of the built-in needle valve. Order thermometer separately.

Cleveland Flash Tester, Natural Gas H-2100
 Shipping wt. 19lbs (8.6kg)

Replacement Parts/Accessories

Description	Model
Cast-iron support base	H-21335
Support rod	H-21370
High-temp. burner	H-5550
Test burner	H-2112
Flash cup platform	H-2111
Flash cup	H-2060
Thermometer clamp	H-8900
Thermometer*	H-2600.11F



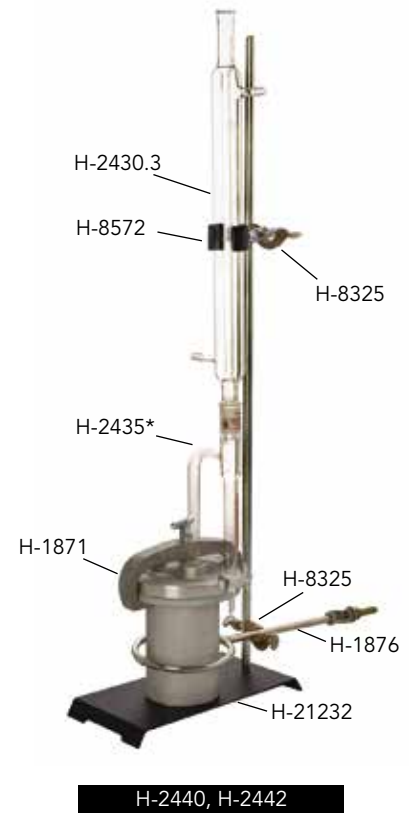
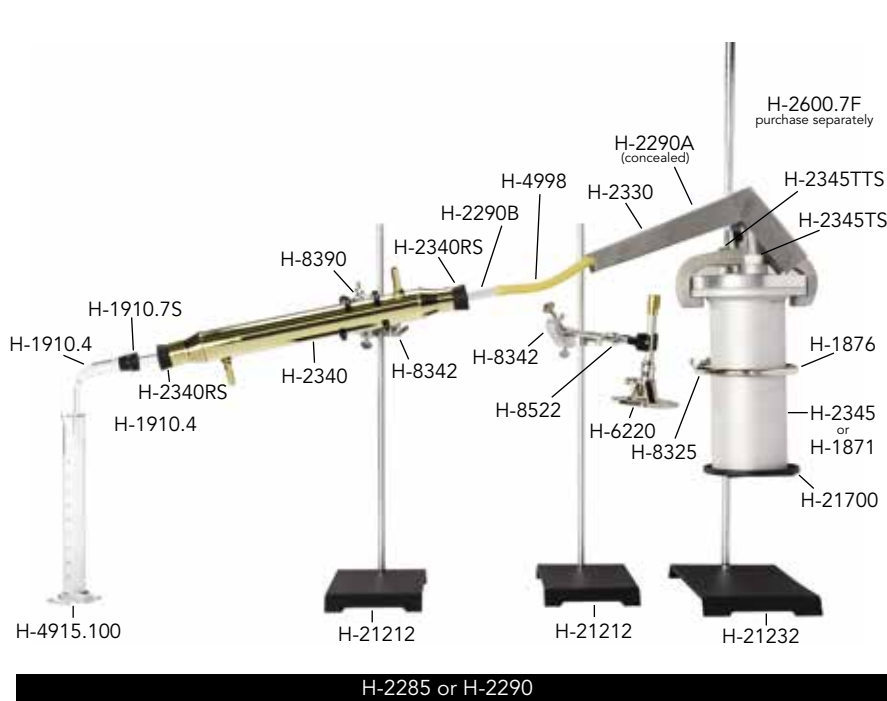

Distillation Set for Residue and Oil Distillate in Emulsified Asphalts

ASTM D6997; AASHTO T59

The distillation set is designed to meet the requirements of the Standards listed above. Use of this set will allow the user to accurately determine the representative portion of residue in emulsified asphalts. Two models are available. The H-2285 uses the large H-2345 still and the H-2290 uses the small H-1871 still. For a detailed explanation of the test procedure refer to the ASTM or AASHTO standards listed above. The complete set is comprised of the items listed in the chart below. Order H-2600.7F thermometer separately.

Distillation Set for Emulsified Asphalt H-2285
 Shipping wt. 28lbs (12.7kg)

Distillation Set for Emulsified Asphalt H-2290
 Shipping wt. 30lbs (13.6kg)

Distillation Set Components

Description	Model
Still, aluminum, small	H-1871
Ring burner	H-1876
Support stands (2 in set)	H-21212
Support stand	H-21232
Support shelf	H-21700
Burner	H-6220
Condenser	H-2340
Graduated cylinder	H-4915.100
Tube shield	H-2330
Straight glass tube	H-2290B
Bent glass tube	H-2290A
Adapter	H-1910.4
Clamp, brass	H-8325
Clamp	H-8390
Clamp holders (2 in set)	H-8342
Clamp	H-8522
Rubber tubing	H-4998
Still stopper (1)	H-2345TTS
Stopper, ptfе	H-2345TS
Stoppers, rubber (2)	H-2340RS
Stopper, rubber	H-1910.7S

Dean Stark Moisture Test Apparatus, Gas Type

ASTM D95, D244, D1461,E123; AASHTO T59, T110

The Dean Stark moisture test apparatus is used to determine the water content in petroleum products, tars, emulsified asphalts and other bituminous materials by the distillation method. The distillation process allows the water in the test sample to be isolated and collected in the receiver of the Trap. This model uses an aluminum still, which is heated by a gas, ring burner. The complete set is comprised of the items listed in the table below.

Description	Model
Ring burner	H-1876
Aluminum still, 0.95L	H-1871
Distillation trap, 20ml, 25ml, or 10ml	H-2435.25 H-2435.10
Condenser, liebig	H-2430.3
Support stand	H-21232
Clamp, brass	H-8325
Clamp, round jaw, coated	H-8572

Dean-Stark, Gas-Heated, 20ml H-2440
 Dean-Stark, Gas-Heated, 10ml H-2442.10
 Dean-Stark, Gas-Heated, 25ml H-2442.25
 Shipping wt. 30lbs (13.6kg)

CAUTION

CAUTION These thermometers contain mercury. There are restrictions on their sale and shipment. Please check laws in your area or contact us before ordering. Due to Illinois law, Humboldt must drop-ship these items from New Jersey. Mercury Thermometers require ground shipment in the U.S. Not sold outside United States.

ACCESSORIES

Digital and mercury-free mercury thermometers, see pages: 306-308, 312.



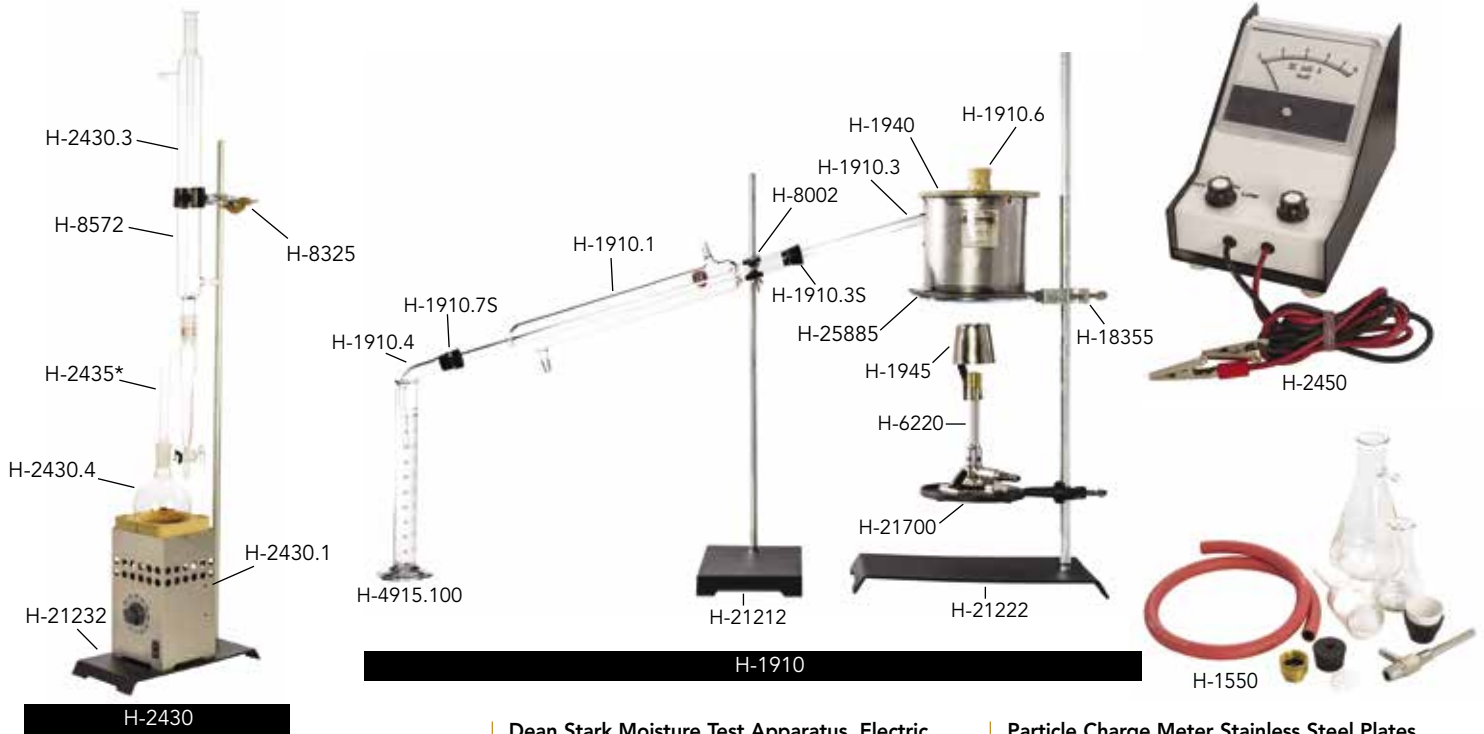

Distillation Set for Cut-Back Asphaltic (Bituminous) Products

ASTM D402; AASHTO T78

The H-1910 distillation set is designed to meet the requirements of the Standards listed above. Use of this set will allow the user to measure the amount of the more volatile constituents in cutback asphaltic products. For a detailed explanation of the test procedure refer to the ASTM or AASHTO standards listed above. The complete set is comprised of the items listed in the chart below. Order H-2600.8F thermometer separately.

Distillation Set for Cut-Back Products H-1910

Shipping wt. 16.8lbs (7.6kg)

Description	Model
Flask	H-1910.3
Condenser	H-1910.1
Adapter	H-1910.4
Distillation shield	H-1940
Flame shield	H-1945
Graduated cylinder	H-4915.100
Burner	H-6220
Clamp	H-8002
Support ring	H-18355
Support stand	H-21212
Support stand	H-21222
Support shelf	H-21700
Wire gauze	H-25885
Stopper, rubber	H-1910.7S
Stopper, rubber	H-1910.1S
Stopper, cork	H-1910.6

Dean Stark Moisture Test Apparatus, Electric

ASTM D95, D244, D1461, E123; AASHTO T59, T110

The dean stark moisture test apparatus is used to determine the water content in petroleum products, tars, emulsified asphalts and other bituminous materials by the distillation method. The distillation process allows the water in the test sample to be isolated and collected in the receiver of the Trap. This model uses a glass flask, which is heated by an electric heater. The complete set is comprised of the items listed in the table below.

Description	Model
Electric, heater 0-750W	H-2430.1
Flask, 500ml	H-2430.3
Distillation trap, 25ml, or 10ml	H-2435.25 H-2435.10
Condenser, liebig	H-2430.3
Support stand	H-21232
Clamp, brass	H-8325
Clamp, round jaw, coated	H-8572

Dean-Stark, Electric-Heated, 10ml H-2430

Dean-Stark, Electric-Heated, 25ml H-2430.4F

Shipping wt. 30lbs (13.6kg)

Particle Charge Meter Set

ASTM D7402; AASHTO T59

The particle charge meter identifies cationic emulsified asphalts by the migration of the particles to a negatively charged electrode (cathode) by means of a direct current. Allows selection of emulsified asphalts that are compatible with the available aggregate or sand. Set includes particle charge meter with positive- and negative-identified electrodes; a set of two H-2452 steel plates.

Particle Charge Meter Set, 110V 60Hz H-2450

Particle Charge Meter Set, 220V 50/60Hz H-2450.4F

Shipping wt. 12.9lbs (1.3g)

Particle Charge Meter Stainless Steel Plates

ASTM D7402; AASHTO T59

Set of two 1" x 4" (25.4 x 101.6mm) stainless steel plates for use with H-2450.

Particle Charge Meter Plates H-2452

Shipping wt. 0.3lbs (1kg)

Solubility of Bituminous Materials Test Set

ASTM D4, D2042; AASHTO T44

Test set is used to determine the degree of solubility in trichloroethylene of asphalt materials having little or no mineral matter. The portion that is soluble represents the active cementing constituents.

Solubility of Bitumen Material Test Set H-1550

Shipping wt. 6lbs (2.7kg)

H-1550 Parts	Model
Gooch crucible, 28ml	H-1550.1
Crucible holder	H-1550.2
Buchner funnel	H-1550.3
Stopper with #7 hole	H-1550.5
Filters, glass fiber, 10pk	H-1550.8
Flask, 125ml	H-1883
Rubber tubing	H-1448RT
Filter pump, Chapman	H-12020
Erlenmeyer flask, vented 500ml	H-4913.500





Still, Aluminum

ASTM D95, D244, D1461, D6997, E123; AASHTO T59, T110

Used primarily in standards for determining water in crude petroleum, tars and derivatives of those materials. Large model, 3.75" x 9.5" (95mm x 241mm) ID, has three tubulures, two drilled 10/18 and one drilled 24/40. The small model, 3.5" x 6" (89mm x 152mm) ID, has a 1 qt. (0.95L) capacity and one tubular. Both are cast aluminum.

Still, Large Aluminum **H-2345**
 Still, Small Aluminum **H-1871**
 Shipping wt. 6.5lbs (2.9kg)

Stoppers for Stills

Teflon stoppers for use with H-2345 and H-1871 Stills.

Stopper for Glass Tubing **H-2345TS**
 Stopper for Thermometer **H-2345TTS**
 Shipping wt. 0.2lbs (0.09kg)

Ring Burner

ASTM D244; AASHTO T59

Can be used with all gases. 4.75" (121mm) ID x 5.5" (140mm) OD. Overall shank length is 11" (279mm) with .375" (10mm) serrated hose connection. Guide pins keep burner equidistant around still. Fletcher attachment regulates gas and air.

Ring Burner **H-1876**
 Shipping wt. 1.4lbs (.63kg)

Distillation Shield

ASTM D402; AASHTO T78

Use with H-1910. Flanged, open-end, stainless steel cylinder with .125" ceramic lining and two-part cover. For use with 500ml flask. Flame distillation only

Distillation Shield **H-1940**
 Shipping wt. 1.5lbs (.68kg)

Flame Shield

ASTM D402; AASHTO T78

Use with H-1910. Stainless steel, spot-welded cone 2" (51mm) dia. at bottom with spring clip to fit 7/16" to .625" (11 to 16mm) burner tubes.

Distillation Shield **H-1945**
 Shipping wt. 0.3lbs (1.1kg)

Burner Chimney

Fits standard 4" (102mm) rings.

Burner Chimney **H-1946**
 Shipping wt. 3lbs (1.3kg)

Condenser Jacket

ASTM D244; AASHTO T59

For use with H-2285 and H-2290. Brass, 15" long inlet/outlet tubulures on opposite sides of jacket.

Condenser Jacket **H-2340**
 Shipping wt. 3lbs (1.3kg)

Connecting Tube Shield

ASTM D244; AASHTO T59

For use with H-2285 and H-2290. Stainless steel.

Connecting Tube Shield **H-2330**
 Shipping wt. 1lbs (.45kg)

Still Cleaner

Use with H-1871 and H-2345. Tool to remove residue from interior of still, 13" x 4" (328 x 101mm) diameter.

Still Cleaner **H-2348**
 Shipping wt. 1.3lbs (.58kg)

H-2435.25



Glass Distillation Trap, 25ml

ASTM D95, D1461; AASHTO T78

25ml distillation trap graduated 0.1ml from 0 to 25ml.

Glass Distillation Trap, 25ml **H-2435.25**
 Shipping wt. 1.1lbs (.49kg)

Glass Distillation Trap, 10ml

ASTM D95, D1461; AASHTO T78

10ml distillation trap graduated 0.1ml from 0 to 1ml and 0.2ml from 1ml to 10ml.

Glass Distillation Trap, 10ml **H-2435.10**
 Shipping wt. 1lbs (.49kg)

Glass Distillation Trap, 5ml

ASTM D95, D1461; AASHTO T78

5ml distillation trap graduated 0.1ml.

Glass Distillation Trap, 5ml **H-2435.5**
 Shipping wt. 1lbs (.45kg)

Glass Distillation Trap, 20ml

20ml distillation trap graduated 0.1ml.

Glass Distillation Trap, 20ml **H-2435.20**
 Shipping wt. 1.5lbs (.68kg)





Vacuum Pycnometer Set (4.34L) for Rice Test

ASTM D2041; AASHTO T209, T283

Used in rice testing to determine the maximum specific gravity of bituminous paving mixtures with maximum aggregate size up to 19.1mm (.75"). The H-1750 provides a 4.34L volume with a 2.9L max. sample volume and typically a 2500g required sample size and a 7.5" ID x 6" depth. Set includes aluminum volumetric canister; volumetric lid; flat, vinyl vacuum lid with O-ring and a metal water vacuum aspirator with 3/8" IPT and 6' hose with release valve and fittings. Unit achieves vacuum using an aspirator or optional vacuum pump.

This set is also available in stainless steel, order H-1750SS. For those who want to use smaller test samples, the H-1751 is available. The H-1751 provides a 2.9L volume with a 1.9L maximum sample volume for a typical sample size of 1500g. It measures 7.5" ID x 4" depth, but the H-1751 does not comply with ASTM specs.

A larger volume model pycnometer is also available. It provides a 5.8L volume with a 3.9L maximum sample volume and a 4000g typical sample size. It measures 7.5" ID x 8" depth.

All models can be used with H-1756A vibrating apparatus or H-1782 de-airing device, and H-1754D manometer, sold separately. See page 265 for vacuum pumps. Replacement parts are available, please inquire.

- Vacuum Pycnometer Set, 6" (4.34L) H-1750
- Vacuum Pycnometer Set, SS, 6" (4.34L) H-1750SS
- Vacuum Pycnometer Set, 4" (2.9L) H-1751
- Vacuum Pycnometer Set, 8" (5.8L) H-1755A

Ship wt. 13lbs. (5.8kg)

Pycnometer Replacement Lid

Replacement lid for models H-1750, H-1751 and H-1755A.

- Pycnometer Replacement Lid H-1750.2
- Ship wt. 4lbs. (1.8kg)

Pycnometer Lid, O-Ring

Replacement o-ring for models H-1750, H-1751 and H-1755A.

- Pycnometer Lid, O-Ring H-1750.3
- Ship wt. 0.05lbs. (0.02kg)

Vacuum Pycnometer Set, Large-Capacity

AASHTO T209, T283

Large-capacity unit, 10L (2.64 gal.), 6000g (13.2 lbs.) sample weight, with maximum aggregate size of 50mm (2"). The set features a domed, transparent cover for easy observation of sample testing, perforated plastic shelf, which some States require; water inlet valve and .25" ID hose, quick-disconnect, vacuum gauge, vacuum hose and aspirator with 3/8" NPT fitting. Flange OD is 10.75" (273mm); maximum clearance above plate is 7.75" (197mm). Use with H-1826A.3F vibrating table, and H-1754D manometer, sold separately. See page 165 for vacuum pumps. Replacement parts are available, please inquire. Dimensions: 9.5" ID x 12.125" (240 ID x 311mm)

- Vacuum Pycnometer Set, Large H-1820
- Ship wt. 10lbs. (4.5kg)

Slow-Release Valve for Vacuum Pycnometers

ASTM D2041; AASHTO T283

For use with H-1750, H-1755SS, H-1751, H-1755A and H-1820 for greater accuracy and shorter dry back time. Brass valve maintains 30mm vacuum pressure on sample.

- Valve, Slow-Release H-1749
- Ship wt. 0.6lbs. (.2kg)

Aspirator Filter Pump

Provides excellent performance for providing a vacuum for pycnometer applications. Water inlet is .375" and length is 5.375" (137mm). Nickel-plated with serrated tail and side arm.

- Aspirator Filter Pump H-12090
- Ship wt. 0.25lbs. (.11kg)

Manometer, Digital

A precise measurement device designed to replace mercury-filled manometers used in Rice test applications. This portable, hand-held device can be easily moved around the laboratory. Holes are provided for bench or wall mounting and a .375" barb fitting is used for quick connections. The instrument features a digital display range of 0 to 1000mm Hg (absolute) at a resolution of 0.1mm Hg. The device has a rated accuracy of +/-0.5% full scale and is powered by one 9V battery or AC adapter, both are included.

- Manometer, Digital, 120V 60Hz H-1754D
- Manometer, Digital, Certified H-1754D-CA
- Manometer, Digital, 220V 50/60Hz H-1754D.4F
- Manometer, Digital, Certified H-1754D.4F-CA

Ship wt. 2lbs. (.9kg)



H-1756.3F



H-1826.3F



H-1782



H-1753 shown in use with H-1782



HA-1665

De-airing Agitator

ASTM D2041; AASHTO T209, T283

Heavy-duty, vibrating, de-airing agitator for use with H-1750, H-1750SS, H-1751 and H-1755A pycnometers keeps sample material loose for more reliable test results. Strong, rugged-duty vibrators and sturdy bases having integral, heavy-duty on/off switches. Exclusive quick-release cam/lock fasteners allow quick placement and removal of canister.

De-airing Agitator, 120/220V 50/60Hz H-1756.3F



Shipping wt. 16 lbs (7.2kg)

De-airing Agitator, Large

AASHTO T209, T283

For use with the H-1820 large pycnometer. Heavy-duty vibrating Apparatus keeps sample material loose for more reliable test results. Strong, rugged-duty vibrators and sturdy bases having integral, heavy-duty on/off switches. Exclusive quick-release cam/lock fasteners allow quick placement and removal of canister.

De-airing Agitator, 120/220V 50/60Hz H-1826.3F



Shipping wt. 18 lbs (8.16kg)

De-Airing Flask Attachment

For use with H-1756A and H-1782, flask not included.

De-Airing Flask Attachment H-1753



Shipping wt. 1.3 lbs (.58kg)

Orbital De-Airing Device

The Humboldt orbital de-airing device is designed for use in maximum specific gravity and density determinations of bituminous paving mixtures. Through the use of an orbital shaking action, material densification that entraps air is virtually eliminated, resulting in more accurate and uniform test results. The front panel incorporates a variable

speed controller with a range of 10 to 250 rpm and an LED programmable timer with an accuracy of better than $\pm 0.1\%$. The orbital diameter of the 11" x 12" (279 x 305mm) platform is set at 1.5" (38.1mm). Taking up little counter space, the base is 10" x 10" (154 x 154mm) and has an overall height of 16" (406mm). Quick release clamps are used to permit quick mounting and removal of the pycnometer. The optional H-1753 flask attachment allows the user to conduct tests using a laboratory flask.

Orbital De-Airing Device, 120V 60Hz H-1782

Orbital De-Airing Device, 220V 50/60Hz H-1782.4F



Shipping wt. 38 lbs (17kg)

AutoRice Controller

ASTM D2041; AASHTO T209, T283

The AutoRice is an automatic control unit allowing laboratory technicians to quickly conduct and monitor specific gravity tests with the press of a button. Designed to accurately control and monitor the vacuum pressure, vacuum time and shaker vibration frequency for the Rice test, ASTM D2041 and AASHTO T209. The AutoRice ensures more consistent inter-laboratory repeatability and accuracy. The AutoRice will start the vacuum pump, regulate the vacuum pressure, precisely control the vacuum time and monitor the shaker frequency. Currently, the AutoRice acceleration monitor and shaker frequency is a parameter that is not monitored during the test. Data from the Rice test can be downloaded via the USB port, where results can be reviewed to assure accuracy and adherence to test specifications. The unique, compact design allows AutoRice to fit on a benchtop or mount to a wall and works with glass flasks and metal container setups.

Features:

- Reduces operator errors by automating test parameters; improving accuracy and repeatability
- Measures shaking frequency and acceleration to prevent stripping damage to the sample
- Automates saturation process for AASHTO T283 (moisture damage)
- Provides capability to enter weights and calculate max specific gravity results
- Replaces digital vacuum gauge used in Rice setup
- Replaces digital vacuum gauge used in Rice setup
- Stores test records (vacuum pressure, vacuum time, frequency and acceleration)
- Easy setup with menu driven software
- The AutoRice can output test data to a portable USB drive.

AutoRice Controller

HA-1665



Ship wt. 25lbs. (11.4kg)

PumpSaver

The PumpSaver is a unique new method for the removal of moisture in air prior to entering a vacuum pump. The device extends the life of vacuum pumps by reducing the amount of water entering the pump. It also increases pump efficiency by offering a lower resistance to air flow as opposed to a desiccant style air drier that actually inhibits the free flow of air. Using the PumpSaver also eliminates the requirement for a desiccant type air drier and eliminates the need to continually replace or recycle desiccant materials. The PumpSaver is



HA-1666



H-1759



H-1758



H-1763A



H-1762



H-1757



H-1764



H-1770

used to improve the accuracy, efficiency, reliability and repeatability of your tests requiring a vacuum pump, such as the Rice test, ASTM D2041 and AASHTO T209. PumpSaver connects to your vacuum pump and acts as a moisture trap eliminating the need for desiccants or in-line moisture filters to protect the pump from moisture damage.

- Reduces the number of oil changes per year
- Improves efficiencies
- Eliminates flow restricting desiccant cartridges
- Increases pump life and efficiencies

PumpSaver HA-1666
UPS Ship wt. 5lbs. (2.3kg)

AutoRice USB Shaker Sensor HA-1667
UPS Ship wt. 2lbs. (0.9kg)

Indicating Drierite Air Drying Unit

Easily installs in-line between vacuum pump and rice test equipment. This refillable unit measures 2.625" by 11.375" (667 x 289mm) with hose barbs at both ends, which can accept 0.25" to 0.375" flexible tubing. Supplied complete with 650g of 8 mesh, indicating desiccant.

Indicating Drierite Air Drying Unit H-1759
UPS Shipping wt. 3.1 lbs (1.4kg)

Indicating Drierite Desiccant

ASTM D2041

Indicating drierite is impregnated with cobalt chloride. This desiccant is blue when dry and changes to pink upon absorption of moisture. The color change is pronounced and clearly visible. This makes indicating drierite valuable when it is necessary to know with certainty that dryness is being maintained and to signal when the drying agent should be replaced. It has the same efficiency as regular drierite and can be regenerated for reuse.

Indicating Drierite Desiccant, 1lb/8 mesh H-1758
UPS Shipping wt. 2 lbs (.9kg)

Indicating Drierite Desiccant, 5lb/8 mesh H-1761
UPS Shipping wt. 10 lbs (4.5kg)

Drierite Desiccant, 8 mesh ASTM D2041

Replacement desiccant for air drying unit. Protects vacuum pump by removing final traces of moisture.

Drierite Desiccant, 1 lb H-1757
UPS Shipping wt. 2.5 lbs (1.1kg)

Drierite Desiccant, 5 lb H-1767
UPS Shipping wt. 9 lbs (4kg)

High Vacuum Pump

Direct-drive two-stage rotary sliding vane high vacuum pump features gas ballast and trap to reduce risk of oil being sucked into the system. Produces free air displacement 85L per minute (3 cu. ft. per minute) and maximum vacuum 29-30". Operating temperature is 30 to 170°F (-1.11 to 76.6°C). Has 0.25" OD intake ports for 0.25" ID tubing. Dimensions: 11.25" x 15.5" x 6.5" (28.6 x 39.4 x 16.5cm).

High Vacuum Pump 120V 60Hz H-1763A
High Vacuum Pump 220V 50/60Hz H-1763A.4F
UPS Shipping wt. 31 lbs (14kg)

Two-Stage Oil-less Vacuum Pump,

Split-capacitor four-pole, two-stage oil-less diaphragm vacuum pump pulls 29" Hg maximum-obtainable vacuum.

Two-Stage Pump, 120V 60Hz H-1762
Two-Stage Pump, 230 50/60Hz H-1762.4F
UPS Shipping wt. 25.7 lbs (11.6kg)

Two-Stage Vacuum Pump

Designed for continuous use, this two-stage, belt-driven pump operates on the oil-sealed rotary vane principle and is ideal for distillation, filtration, degassing and as a roughing pump for high-vacuum systems. Pumps are mounted on rectangular steel base plate and include V-belt and belt guard that totally encloses belt and pulleys. Pump pulls 29-30" maximum vacuum. Includes initial supply of oil plus an extra quart of HyVac® oil.

Two-Stage Pump, 120V 60Hz H-1764
Two-Stage Pump, 230 60Hz H-1764.2F
Two-Stage Pump, 230 50Hz H-1764.5F
UPS Shipping wt. 55 lbs (24.9kg)

Vacuum Pump

High-vacuum, small capacity, general-purpose vacuum pump with belt guard has two-stage construction for efficiency with low maintenance. Features metal vanes and vented exhaust for introduction of air to remove condensable vapors. Pump is filled with oil; an extra quart is included. Exhaust filter is available separately. Guaranteed ultimate vacuum is 25-29" (635-736mm) mercury, and free-air displacement is 25L/min. (0.9cfm).

Vacuum Pump, 120V 60Hz H-1770
UPS Shipping wt. 80 lbs (36kg)





H-1766.2



H-1766.3



H-1768.3



F85930-33
F85938



H-1304



H-4296A



H-4296



AY1087X1

Vacuum Pump Oil

High purity oil with low vapor pressure that does not materially increase at temperatures up to 50°C (122°F) and viscosity sufficiently low for use at 125°C (59°F). Oil remains fairly constant up to 50°C (122°F).

Vacuum Pump Oil, 1 Quart **H-1766.2**
Shipping wt. 3 lbs (1.3kg)

Vacuum Pump Oil, 1 Gallon **H-1766.3**
Shipping wt. 9 lbs (4kg)

Vacuum Pump Oil, 5 Gallon **H-1766.4**
Shipping wt. 41.2 lbs (18.6kg)

Vacuum Pump Oil, 1-Qt. (Case of 12) **H-1766.5**
Shipping wt. 25 lbs (11.3kg)

Vacuum Pump Oil, 1 Gallon (Case of 6) **H-1766.6**
Shipping wt. 54.6 lbs (24.7kg)

Flushing Oil for Vacuum Pumps, 1 gallon

Purges contaminants and condensables, such as water and solvents from all mechanical vacuum pumps. Use between oil changes minimizes contamination of new oil by residue from old oil; extends pump life.

Flushing Oil for Vacuum Pumps, 1 gal. **H-1768.3**
Shipping wt. 8.3 lbs (3.7kg)

Digital Timer, Humboldt

Humboldt's portable digital timers automatically shut off electrical equipment at a set time. Two models are available, one for up to 60 minutes, the other up to 99 seconds. Feature easy-to-use digital interface and two-plug, AC receptacle. The accuracy for both versions is 0.5%.

Digital Timer, Minute, 120V 50/60Hz **H-4296A**

Digital Timer, Minute, 220V 50/60Hz **H-4296A .4F**

Digital Timer, Second, 120V 50/60Hz **H-4299**

Digital Timer, Second, 220V 50/60Hz **H-4299.4F**

Ship wt. 3lbs. (1.3kg)

Universal Analog Timer

Portable timer automatically shuts off electrical apparatus at set time up to 60 minutes. Features two-plug AC receptacle.

Universal Analog Timer, 120V 60Hz **H-4296**

Universal Analog Timer, 220V 50/60Hz **H-4296.4F**

Shipping wt. 2.6 lbs (1.1kg)

Asphalt Content/Binder Ignition Furnace

ASTM D6307

The asphalt content/binder furnace with internal automatic balance is an environmentally-friendly and cost-effective method for the accurate determination of asphalt content. Developed by NCAT, the National Center for Asphalt Technology. The furnace's large capacity handles samples up to 4,000 grams. Ignition method reduces testing time compared to solvent testing methods and automatic operation frees technicians for other tasks. Temperature range is: 392 to 1202°F (200 to 650°C). 4,800 watt operation Accurate internal balance monitors weights automatically throughout ignition to within ±0.1 gram. Easy operation— simply enter sample weight, calibration factor, load the sample, and push start, when unit beeps at test end, push stop, and sign receipt. Door safety features, such as a software-activated door lock, an automatic interlock that cuts power when door is open, full 180 degree door opening and door hinge lock eliminate harmful solvents and make operation easy. Ignition Furnace comes complete with accessory package AY1087X1. CE-approved. Chamber dimensions: 14"W x 10.5"H x 14"D (355 x 266 x 355mm). Shipping dimensions: 32"W x 32"D x 60"H (813 x 813 x 1524mm.)

Content/Binder Ignition Furnace w/ Accessory Package, 240V 50/60Hz, 20 amp **F85930-33**

Shipping wt. 383 lbs (173.7kg)

Content/Binder Ignition Furnace w/ Accessory Package, 208V 60Hz, 23 amp **F85938**

Shipping wt. 280 lbs (127kg)

Content/Binder Ignition Furnace (furnace only), 240V 50/60Hz, 20 amp **F85930-33X**

Shipping wt. 357 lbs (161.9kg)

Content/Binder Ignition Furnace (furnace only), 208V 60Hz, 23 amp **F85938X**

Shipping wt. 230 lbs (104.3kg)

Accessory Package for Ignition Furnaces

Accessory package includes: 4 baskets, 2 trays, 2 covers, handle, cooling cage, insulated plate, gloves, face shield, 4 rolls of printer tape, balance calibration plate and anderol oil.

Description	Part #
Exhaust tubing, 3"ID (sold by foot)	H-1515
Exhaust tubing, stainless, 3"ID (sold by foot)	H-1515SS
Printer paper	PRX2
Baskets (set of 2)	AY1087X6

Ignition Furnace Accessory Package **AY1087X1**
Shipping wt. 75 lbs (34kg)

Rhoma-Sol™ Specialty Emulsifier

Spray-on solution used in the removal of asphalt and tack oil from testing, paving, oiling, patching, reclaiming and other work zone equipment. Contains no hazardous petroleum solvents and is 100% biodegradable. Flammable, must ship by truck domestically and as Dangerous Goods Internationally.

Rhoma-Sol™ Specialty Emulsifier **H-1304**
Shipping wt. 2 lbs (0.9kg)



ACCESSORIES

For gloves, see pages: 350.





H-1451



H-1456



H-1461



H-1485.627

Asphalt Centrifuge Extractor (Explosion Proof)
ASTM D2172; AASHTO T164

The asphalt centrifuge extractor is designed for determining the percentage of bitumen in asphaltic mixtures. Available in 1500g and 3000g capacities, these extractors conform to the explosion-proof standards for the safety of operating personnel.

All models feature a removable, aluminum bowl assembly, which quickly lifts out of the sealed housing for efficient specimen handling. A simple, control knob adjusts bowl speed up to 3600 rpm, and, an electric brake stops the centrifuge in seconds when extraction is complete. The heavy, cast-aluminum bowl cover latches securely in place and features an integral solvent dispensing cup for easy pouring of the solvent into the bowl. Power is supplied by a reliable 1/8hp DC motor. Extractors are supplied complete with 25 filter discs. Replacement filter discs (100-packs) are available, see chart at bottom right of page.

Dimensions: 1500g units: 12" x 20" x 22" (305 x 508 x 559mm); 3000g units: 14" x 20" x 22" (356 x 508 x 559mm).

- Extractor, 1500g, 115V 60Hz H-1451
- Extractor, 1500g, 220V 50/60Hz H-1451.4F
- Extractor, 3000g, 115V 60Hz H-1474
- Extractor, 3000g, 220V 50/60Hz H-1474.4F

Shipping wt. 85lbs (38.5kg)

Centrifuge Extractor (Open Motor)

ASTM D2172; AASHTO T164

This extractor is an open-motor version of the explosion-proof models described above. While it is safe to operate, it does not provide the added safety of the explosion-proof design. This extractor is a great economical choice or for those who need an extractor, but may not use it extensively. Not available in 220V model.

- Extractor, 1500g, 115V 60Hz H-1456
- Extractor, 3000g, 115V 60Hz H-1471

Shipping wt. 70lbs (31.7kg)

Centrifuge Extractor (Explosion Proof)

ASTM D2172; AASHTO T164

Available in 1500g and 3000g capacities, these extractors conform to the explosion-proof standards for the safety of operating personnel.

All models feature a removable aluminum bowl assembly, which quickly lifts out of the sealed housing for efficient specimen handling. A simple, control knob adjusts bowl speed. The heavy, cast-aluminum bowl cover latches securely in place and features an integral solvent dispensing cup for easy pouring of the solvent into the bowl.

Extractors are supplied complete with 25 filter discs. Replacement filter discs (100-packs) are available, see chart at bottom right of page.

Dimensions: both sizes: 18" x 18" x 18" (457 x 457 x 457mm).

- Extractor, 1500g, 115V 60Hz H-1466
- Extractor, 1500g, 220V 50/60Hz H-1466.4F
- Extractor, 3000g, 115V 60Hz H-1473
- Extractor, 3000g, 220V 50/60Hz H-1473.4F

Shipping wt. 75lbs (34kg)

Auto Centrifuge Extractor, (Explosion Proof)

ASTM D2172; AASHTO T164

These extractors feature automated, auto control of the unit. Timer allows unit to run unattended for a specific period of time (1 to 10 minutes). Unit brakes and stops automatically when time expires and holds last test cycle settings in memory for repeatable tests. Time and speed can be set quickly with the rotating dials below the digital display that shows the settings. The controller can also be wall- or remotely-mounted for visual ease as well as vibration isolation.

Power is supplied by a reliable 1/8hp DC motor. Extractors are supplied complete with 25 filter discs. Replacement filter discs (100-packs) are available, see chart at bottom right of page.

- Extractor, 1500g, 115V 60Hz H-1461
- Extractor, 1500g, 220V 50/60Hz H-1461.4F
- Extractor, 3000g, 115V 60Hz H-1465
- Extractor, 3000g, 220V 50/60Hz H-1465.4F

Shipping wt. 114lbs (51.7kg)

Auto Centrifuge Extractor (Open Motor)

ASTM D2172; AASHTO T164

This extractor is an open-motor version of the explosion-proof models described above. While it is safe to operate, it does not provide the added safety of the explosion-proof design. This extractor is a great economical choice or for those who need an extractor, but may not use it extensively. Not available in 220V model.

- Centrifuge Extractor, 1500g, 115V 60Hz H-1460
- Centrifuge Extractor, 3000g, 115V 60Hz H-1464

Shipping wt. 76lbs (34.4kg)

Centrifuge Extractor Replacement Parts	
Description	Model
Bowl for H-1456, H-1466	H-1456B
Bowl for H-1471, H-1473	H-1471B
Bowl cover, H-1456, H-1466	H-1456BC
Bowl cover, H-1456, H-1466	H-1471BC
Cover nut	H-1471N
Clamp, all models	H-1471C
O-Ring, all models	H-1471RV
Brake band, all models	H-1456BB
Brake band assembly, all	H-1471BBA

Filter Papers for Centrifuge Extractors

All filter papers for centrifuge extractors have a medium speed and a flow rate of 85 ml/min. The thickness is 0.71" with a 4 micron retention. Filter- come in packages of 100.

Filter Papers for Centrifuge Extractors See chart

Shipping wt. 4lbs (1.81kg)

Extractor / Size	Model
H-1451, H-1452 (9.75" OD x 1.75" ID)	H-1481.627
H-1474 (11.625" OD x 5" ID)	H-1485.627
H-1456, H-1466, H-1460, H-1461 (10" OD x 5" ID)	H-1487.627
H-1471, H-1473, H-1464, H-1465 (12.25" OD x 5" ID)	H-1489.627





Asphalt Solvent Recycler

This unit has been designed to recycle the solvents used in asphalt extraction tests. It successfully extracts pure solvent from the oil and wastes generated from the extraction process and generates clean solvent ready for reuse in a new test. The unit reduces the need for new solvent and eliminates problems with solvent disposal.

- UL 2208 Certified
- 6-gallon, heavy-duty stainless steel boiling tank
- Air-cooled, no water hookup necessary
- Bag-lined tank allows easy removal of solid contaminants
- Vacuum-assist option for higher boiling solvents
- Quiet operation and low maintenance
- Multiple safety controls with automatic shutoffs
- Mobile – mounted on locking wheels for easy relocation & stabilizer bars for added support
- Easy installation to standard connection: 220-240V or 120V
- Electric, fill pump available as an option
- Small footprint – 22.25" w x 39" l x 44" h

Description	Model
Operating capacity:	6 gallons / 23 Liters
Voltage:	120V 60Hz or 240V 60HZ
Wattage:	2800 VA (240V) 2300 VA (120V)
Maximum Rated Load:	11.1 A (240V) or 185 A (120V)
Voltage:	120V 60Hz or 240V 60Hz
Net weight:	290 lbs (132kg)
Clamp, round jaw, coated	H-8572

Asphalt Solvent Recycler 120V 60Hz H-1431A
 Asphalt Solvent Recycler 240V 60Hz H-1431.2F
 Not available in 50Hz

Shipping wt. 290 lbs (132kg)



Vacuum Extractor

ASTM D2172 (Method E); AASHTO T164

Basic vacuum extractor for use in quantitative determinations of bitumen in hot-mixed paving mixtures and pavement samples. The H-1449 provides a 12" (305mm dia) filtering surface. Unit includes a connecting hose, (100) H-1497.613 filter papers and test procedure instructions. Use with a 4,000cc erlenmeyer flask and a vacuum pump, see below. For replacement filter paper, use H-1497 series paper from chart at bottom of page.

Vacuum Extractor H-1449A

Shipping wt. 58.6lbs (26.5kg)

Vacuum Extractor Components & Accessories	
Description	Model
Fluorosilicone o-ring	H-1448.1
Stainless steel plate, as provided	H-1448P
Stainless steel plate, heavy-duty	H-1448HP
Rubber Tubing	H-1448RT
Clear, Heavy-wall, Vacuum Tubing	H-1446
4,000cc erlenmeyer flask, meets ASTM D2172 and AASHTO T164 (Method E)	H-4913.4M
8" Sieve adapter	H-1447
High-vacuum pump (see page 165 for info)	H-1763A H-1763A.4F

Filter Papers for Vacuum Extractors						
Size	Filter Speed	Flow Rate (ml/min.)	Thickness	Retention (µm)	Per Pkg.	Model
33cm dia.	Very fast	360	0.51	48	50	H-1497.617
33cm dia.	Very fast	435	1.02	31	100	H-1497.633
33cm dia.	Fast	235	0.25	24	100	H-1497.615
33cm dia.	Medium	60	0.17	6	100	H-1497.613
33cm dia.	Medium	85	0.71	4	100	H-1497.627



Centrifuge Extractor, Filterless

ASTM D1856; AASHTO T164

The continuous-flow filterless centrifuge extractor is ideally suited for use in the extraction of mineral fines from bitumen-laden solvents obtained from standard asphalt extraction tests. In operation, the solvent suspension is fed through the top funnel into a special aluminum beaker, (2) H-1857.5 supplied). Using the high, 11,000 rpm centrifugal force, the liquid moves up the beaker wall and out the overflow tube while the solids remain for easy removal at test completion. The system allows the continuous feeding of the suspension until the solids-retaining capacity of the beaker is reached. The unit is supplied complete with a No. 18 (1.0mm) and No. 200 (75µm) sieve for placement at the top of the inlet funnel. Using this arrangement, an asphalt mix extraction test can be carried out by pre-dissolving the mix with solvent and then pouring the sample into the sieve. Dimensions: 20" x 15" x 33" (508 x 380 x 840mm).

Centrifuge Extractor, Filterless H-1857A
 120V 60Hz H-1857A.2F
 230V 60Hz H-1857A.5F
 230V 50Hz
 Shipping wt. 154lbs (69.8kg)

Aluminum Beaker
 Replacement aluminum beaker for use with the filterless centrifuge extractor.

Aluminum Beaker H-1857.5
 Shipping wt. 2lbs (.9kg)



Reflux Extractor Sets

ASTM D2171, D2172; AASHTO T164 Method B
Used to determine the percentage of bitumen in a paving mixture using hot solvent extraction. Available in 1000g and 3000g versions.

The 1000g set includes: (2) 500g wire screen cones, copper condenser with 0.5" inlet/outlet water tubes, glass jar 6" OD x 18" H (152mm x 457mm) with ground open edges for a tight fit, a H-4942, 6" square hot plate and a 100-pack of 33cm filter paper.

The 2000g set includes: (2) 1000g wire screen cones, copper condenser with 0.5" inlet/outlet water tubes, glass jar 8.75" OD x 18" H (222mm x 457mm) with ground open edges for a tight fit, a H-4943, 9" square hot plate and a 100-pack of 40cm filter paper.

Reflux Extractor, 1000g, 120V 60Hz H-1495
Reflux Extractor, 1000g, 220V 50/60Hz H-1495.4F
Shipping wt. 29.3lbs (13.2kg)

Reflux Extractor, 2000g, 120V 60Hz H-1499
Reflux Extractor, 2000g, 220V 50/60Hz H-1499.4F
Shipping wt. 55lbs (24.9kg)

Reflux Extractor, 1000g Components

Description	Model
Wire screen cone, 500g sample holder (set of 2)	H-1495.1
0.5" Tube copper condenser w/ inlet/outlet water tubes	H-1495.2A
Glass jar with ground open edges	H-1495.3
Electric hot plate	H-4942
Filter paper, 33cm, 100-pack	H-1497.613
FibreChem circle, 8.5"	H-1496

Reflux Extractor, 2000g Components

Description	Model
Wire screen cone, 1000g sample holder (set of 2)	H-1499.1
0.5" Tube copper condenser w/ inlet/outlet water tubes	H-1499.2A
Glass Jar with ground open edges	H-1499.3
Electric hot plate	H-4943
Filter paper, 40cm, 100-pack	H-1498.613
FibreChem circle, 8.5"	H-1496

Pressure Limit Device

For use with reflux extractor kits to protect copper condenser from excessive pressure. For use with 0.5" tubes.

Pressure Limit Device H-1494A
Shipping wt. 0.5lbs (0.22kg)

Filter Papers for Reflux Extraction

Filter papers for use with reflux extractor sets.

Size	Filter Speed	Flow Rate (ml/min.)	Thickness	Retention (µm)	Per Pkg.	Model
33cm dia.	Very fast	360	0.51	48	50	H-1497.617
33cm dia.	Very fast	435	1.02	31	100	H-1497.633
33cm dia.	Fast	235	0.25	24	100	H-1497.615
33cm dia.	Medium	60	0.17	6	100	H-1497.613
33cm dia.	Medium	85	0.71	4	100	H-1497.627
40cm dia.	Medium	85	0.71	4	100	H-1498.627
40cm dia.	Medium fast	60	0.17	6	100	H-1498.613
40cm dia.	Medium fast	235	0.25	24	100	H-1498.615
40cm dia.	Very fast	300	0.51	48	50	H-1498.617

Asphalt Dispensers

Round, melting pot has stainless steel crucible (18 gauge) and shell (20 gauge) to facilitate easy clean up. Choice of 6 quart, or 12 quart models. Includes heavy-duty, adjustable bench mounting stand, which fits either size. Dual-point temperature control allows independent temperature for pot (0-350°) and for valve (1-10°). Digital display may be read in either Centigrade or Fahrenheit. Other features include: multiple-circuit blanket heater for very uniform heat; no-drip 1" ball valve dispenser, 7.25" (184mm) above work surface; 50-watt valve heater; 3" (76mm) fiberglass insulation; separate aluminum cover; 6' power cord.

6-qt capacity— 800 watts; 1

2-qt capacity— 1,200 watts;

Asphalt Dispenser, 6Qt, 120V 60Hz H-1440
Asphalt Dispenser, 6Qt, 220V 50/60Hz H-1440.4F
Shipping wt. 30lbs (14kg)

Asphalt Dispenser, 12Qt, 120V 60Hz H-1442
Asphalt Dispenser, 12Qt, 220V 50/60Hz H-1442.4F
Shipping wt. 20lbs (9.1kg)



H-3839



H-3842A



H-3843A



H-3841.1



H-3841.2



H-3843AHW



H-3842HW

Mixer, 5-Qt.

This mixer can be used for mixing asphalt mixes in the lab. The H-3839 operates on the principle of planetary action where the beater reaches every part of a batch, rotating on its axis in opposite directions as it moves around the bowl. This mixer thoroughly blends, mixes and aerates all ingredients for a consistent, predictable finished batch. Selective agitator transmission has 3 speed settings: 139, 285 and 591 RPM. Direct gear drive and a heavy-duty motor ensure constant mixing speeds under load. A locking hand-lever provides precise raising and lowering of the mixing bowl. Base dimensions: 10.375 x 15" (264 x 381mm). Height: 17" (432mm). The mixer includes a stainless steel bowl, wire whip, dough hook and an aluminum flat beater. It is suggested that a stainless steel beater or a Humboldt extreme-duty whisk be purchased for asphalt mixing applications as the standard mixer parts do not wear well in asphalt applications.

Mixer, 5-Qt. (4.73L), 120V 60Hz H-3839
 Mixer, 5-Qt. (4.73L), 230V 60Hz H-3839.2F
 Mixer, 5-Qt. (4.73L), 230V 50Hz H-3839.5F
Shipping wt. 55 lbs (25kg)

H-3839 Accessories and Replacement Parts

Description	Model
Bowl lid, acrylic	H-3846L
Beater—stainless steel, flat-type	H-3841.1
Bowl—stainless steel, 5 qt. (4.73L)	H-3841.2
Wire loop whip—stainless steel	H-3841WW
Dough hook, aluminum	H-3841DH

Laboratory Bench Mixer, 12-Qt. (11.35L)

The Hobart model HL-120 bowl has a 12-qt. (11.35L) mixing capacity and a 15-minute motor-driven timer. Planetary action of the beater assures thorough blending and mixing. Selective agitator transmission has 3 speed settings: 106, 196 and 358 RPM. Includes stainless-steel bowl, flat-type aluminum grid beater and aluminum dough hook. Base dimension: 14.75" x 20" x 29.5265" (375 x 508 x 750cm).

Laboratory Bench Mixer, 12-Qt. (4.73L) H-3842A
 120V 60Hz H-3842A.4F
 230V 50/60Hz Shipping wt. 185 lbs (83.9kg)

H-3842A Accessories and Replacement Parts

Description	Model
Aluminum beater	H-3842A.1
12-qt. stainless steel bowl	H-3842A.2
Aluminum dough hook	H-3842ADH
Stainless steel wire loop whip	H-3842AWW

Laboratory Bench Mixer 20-Qt. (18.92L)

The Hobart HL-200 mixer has a positive gear drive and planetary mixing action to deliver positive results. Selective agitator transmission has 3 speed settings: 107, 198 and 361 RPM. Exclusive stirring switch provides low (53RPM) speed to facilitate adding liquids to semi-solids. Includes stainless-steel bowl and flat-type aluminum grid beater. Base dimension: 21" x 21.5" x 41.25" (533 x 546 x 1048cm).

Laboratory Bench Mixer, 20-Qt. (18.92L) H-3843A
 120V 60Hz H-3843A.4F
 230V 50/60Hz Shipping wt. 230 lbs (104.3kg)

H-3843A Accessories and Replacement Parts

Description	Model
Aluminum beater	H-3843A.1
20-qt. stainless steel bowl	H-3843A.2
Aluminum dough hook	H-3843ADH
Stainless steel wire loop whip	H-3843A.WW

Humboldt Extreme-Duty Whisks

Custom, hand-made extreme duty whisks are formed from 0.25" dia. stainless steel rod. Designed to stand up to the abuse of mixing heavy aggregate asphalt mixes in the mixers listed above.

Description	Model
For H-3843A (Hobart HL-200 1/2HP) current	H-3843AHW
For H-3842A (Hobart HL-120 1/2HP) current	H-3842AHW
For H-3839 (Hobart N-50A-10) current	H-3841HW
Hobart 20-quart mixer old model (prior to 2007)	H-3843HW
Hobart 12-quart mixer old model (prior to 2007)	H-3842HW



NOTES

Replacement parts for previous models, H-3842 (Hobart A-120) and H-3843 (Hobart A-200) are available, please call. Also, please call for Extreme-duty whisks for these models





Asphalt/Concrete Mixer, 5 gal., Stationary
Chain-driven mixer, ideal for sample batch mixing in either laboratory or field. Separate utility bucket cradles securely inside enameled-steel mixer frame. Maximum capacity 70 lbs (50lb recommended). Built for continuous duty performance. Choice of 4 Mixing angles. Mix bucket speed is 60 rpm with 0.5 HP motor. Configuration includes bucket, H-1690.2 paddle and accessory chain guard.

Asphalt/Concrete Mixer, 5 gal., Stationary
120V 60Hz H-1690
220V 50Hz H-1690.5F
Shipping wt. 55.4 lbs (25.1kg)

H-1690 Mixer Accessories

Description	Model
Mixing paddle for 5 gal. H-1690 mixer	H-1690.2
Deluxe mixing paddle for 5 gal. H-1690 mixer	H-1690.3
Bucket & cover for 5 gal. H-1690 Mixer	H-1690.1

Asphalt/Concrete Mixer, 5 gal., Mobile,
Direct-drive, 5 gallon, portable mixer with 8" semi-pneumatic wheels for mobility. Mix bucket speed is 60 rpm with 0.5 HP motor. Includes mix bucket only. Order desired paddles separately.

Asphalt/Concrete Mixer, 5 gal., Mobile
120V 60Hz H-1691
220V 50Hz H-1691.5F
Shipping wt. 84 lbs (38.1kg)

Asphalt/Concrete Mixer, 10 gal., Mobile,
10 gallon, portable mixer with 8" semi-pneumatic wheels for mobility. Mix bucket speed is 60 rpm with 0.5 HP motor. Includes mix bucket only. Order desired paddles separately, see below.

Asphalt/Concrete Mixer, 10 gal., Mobile
120V 60Hz H-1692
220V 50/60Hz H-1692.4F
Shipping wt. 97 lbs (44kg)

H-1691, H-1692 Mixer Accessories

Description	Model
Asphalt paddle for 5 gal. portable mixer	H-1691.6A
Concrete paddle for 5 gal. portable mixer	H-1691.8A
Concrete paddle for 10 gal. portable mixer	H-1692.9
Mix bucket for 5 gal. mixer	H-1691.4
Mix bucket for 10 gal. mixer	H-1692.5

QuarterMaster™ Asphalt Mix Sample Splitter
The QuarterMaster™ is ideal for dividing the larger asphalt mix samples required in Superpave specifications. The hopper accepts samples up to 120 lb (54kg) of any mix with aggregate between 9.5 to 37.5mm and quarters it into four equal parts. In operation, a simple throw of a lever divides the sample. Using the device ensures greater control, consistency and uniformity in the preparation of test samples. The unit is supplied complete with four sample buckets. Dimensions are 14"W x 17"D x 48"H (356 x 432 x 1219mm). To assist operation, order a H-1702 materials handling scoop.

QuarterMaster™ Sample Splitter H-4122
Shipping wt. 100 lbs (45.3kg)

QuarterMaster™ Quick Funnel Insert
Use Funnel to significantly reduce the hopper size when reduction of smaller samples is desired.

QuarterMaster™ Quick Funnel Insert H-4122QF
Shipping wt. 11.2 lbs (5.08kg)

QuarterMaster™ Replacement Bucket
Replacement galvanized metal bucket for use with QuarterMaster™.

QuarterMaster™ Replacement Bucket H-3372
Shipping wt. 4lbs (1.8kg)



HA-5000A.4F

Superpave GYR Gyratory

ASTM D6925; AASHTO T312; CS9010-1115; CS9010-1230; SHRP M-002, T 0736-2011; TEX-241-F; EN 12697-10

Compaction is achieved by the application of a vertical stress (normally 600KPa (87psi)) via end platens to a known mass of asphaltic mixture within a 150 and 100mm (6" and 4") internal Ø mold. The longitudinal axis of the mold is rotated (gyrated) at a fixed angle to the vertical while the platens are kept parallel and horizontal. During compaction the height of the sample is automatically measured and both the mixture density and void content calculated.

Features:

- Automatic mold insertion and retraction on side table which allows cooling time before extraction without loss of compaction time (especially important for rubberized asphalt)
- 150 mm and 100 mm (6 and 4 inch) internal Ø molds can be tested without changing parts
- Cold mix (emulsion) materials can be compacted and the expelled fluid collected
- Ethernet and multiple USB connections for data acquisition and control system
- User friendly LabVIEW™ software displays results in real time
- Machine calibrated with traceable equipment
- Option for mold up to 300 mm (11.8") high

Software:

- User friendly, intuitive and reliable Windows® software developed using LabVIEW™
- Software allows 3 methods of compaction—number of gyrations, height and target density. The operator is guided through every step of the compaction
- Real-time display of current height, density and void content (%) Data is recorded to disk at regular intervals for further analysis
- Utilities are included for transducer check, diagnostic routines and calibration

Superpave Gyratory, 220V 50/60Hz HA-5000A.4F
 Ship wt. 1120 lbs. (508kg)

Specifications	
Speed	Normally 30 rpm
Stress	Normally 600 kPa (87psi) Maximum 1000 kPa (145psi)
Actuator Stroke	9.85" (250mm)
Internal Angle of Gyration	0.2 to > 2°
Electrical Supply	220V 60 Hz
Specimen Ø mm (inch)	6" (150mm) and 4" (100mm)
Compressed Air	7-10 bar (100-145psi) @ 12.5cfm (350 lpm)
Mixtures	Wet, dry and rubber
Dimensions	31" x 40" x 76" (780 x 1000 x 1920mm)
Working Space Required (WxDxH)	79" x 79" x 87" (2000 x 2000 x 2200mm)
Desktop PC	Included

INSTALLATION

Installation Verification and on-site Training are available for the Gyratory, please inquire.



ACCESSORIES

Accessories are not included and should be ordered separately.

Accessories	Model
Specimen Extruder, Pneumatic	HA-5000.17
Specimen Extruder, Electro-mechanical (for rubberized asphalt option)	HA-5000.18
Rubberized asphalt option	HA-5000.19
Dynamic Angle Verification (DAV) with Hot Mixed Simulator (HMS)	HA-5000.20
150mm Internal Ø mold & platens with specimen temperature measurement	HA-5000.2
150mm Internal Ø mold & platens, slotted for emulsion mix	HA-5000.6
100mm Internal Ø mold & platens, slotted for emulsion mix	HA-5000.4
100mm Internal Ø mold & platens	HA-5000.5
Lift handle for light weight gyro mould	HA-5000.21
150mm Spacer to compact 63mm height on Gyratory	HA-5000.10
Spacer, 100mm to compact 63mm height on HA-5000	HA-5000.11
Shear force display	HA-5000.13
Specimen Temperature Measurement	HA-5000.14
Calibration kit for internal angle	HA-5000.12
100mm Circle Filter Paper (100 pk)	HA-5000.16
(150mm circle filter papers (100pk)	HA-5000.15



Specifications	
Vertical Load (150mm)	10 to 1000 kPa (1000 kPa–10 bar) (800 kPa–8 bar) (700 kPa–7 bar)
Vertical Load (100mm)	23 to 1500 kPa with 7 bar compressor
Vertical Load Control	Auto electronic system
Gyration Rate	Adjustable from 5 to 60 work cycles/min.
Gyratory Angle Adjustable	0 to 2.4°
Number of Cycles	Adjustable from 1 to 5000
Electrical Supply	230V 50/60 Hz
Compressed Air	100-145psi (7-10 bar) @ 350 L/min (12.5cfm)
Mixtures	Wet, dry and rubber
Dimensions	25.2" x 19.7" x 41.3" (640 x 500 x 1050mm)

Accessories	Model
Specimen Cylinder, (100mm)	HA-5950.1
Specimen Cylinder, (150mm)	HA-5950.2
Cylinder w/Holes, (100mm)	HA-5950.3
Cylinder w/Holes, (150mm)	HA-5950.4
Penetration Piston, (100mm)	HA-5950.5
Penetration Piston, (150mm)	HA-5950.6
Metallic Disk, (100mm)	HA-5950.7
Metallic Disk, (150mm)	HA-5950.8
Filter Paper, (100mm)	HA-5950.9
Filter Paper, (150mm)	HA-5950.10
Auto Specimen Extruder	HA-5950.11*
Bench	HA-5950.12
Wheels	HA-5950.13
Internal Angle Measurer	HA-5950.14
Calibration Check for Internal Angle Measure	HA-5950.15

* Requires HA-5950.12 Bench for mounting.



HA-5950.14



ACCESSORIES

Accessories are not included and should be ordered separately.



HA-5950.1, HA-5950.2



HA-5950.3, HA-5950.4

Shown with HA-5950.12 Bench Order Separately



HA-5950.4F

Superpave Gyratory

ASTM D6925; AASHTO T312; CS9010-1115; CS9010-1230; SHRP M-002, T 0736-2011; TEX-241-F; EN 12697-10

This Gyratory Compactor is used to simulate and reproduce the real compaction conditions of actual road paving operations in determining the compaction properties of asphalt.

Its fully-automatic compaction operation provides that both rotary and vertical forces are applied to the specimen by the mechanical head. The gyratory's rigid, steel frame ensures that excellent angle control is maintained through the testing operation.

Load is applied by an electro-pneumatic cylinder, which is servo-controlled by a precision pressure regulator while the height is measured by a linear transducer. Gyratory motion is generated by an eccentric high-precision system allowing an easy set up with precision and constant angle of gyration. The rotation speed is controlled by an inverter through on-board computer control.

In addition to testing standard mixes the Gyratory can also test cold emulsified asphalt mixes using one of the available perforated molds. Machines are factory calibrated to the selected internal angle. The touch-screen, icon-based interface allows for easy test parameter set up and test

execution, as well as data acquisition and data processing.

- Rigid steel frame ensuring excellent angle control.
- Electro-pneumatic action with servo-controlled regulator.
- Full-color, touch-screen control unit
- PC Software for control, acquisition and data processing.
- Optional shear stress measurement.
- Optional integrated balance.
- Optional integrated extruder.

The machine provides direct connection to a LAN network and the internet, which allows for remote machine control, as well as remote communication with technicians for immediate diagnostics and problem solving and for software updates.

Unlimited memory storage with: 2 USB ports, 1 SD card. Machine is factory calibrated and supplied with the internal angle set to 1.16° as specified by ASTM, AASHTO Specifications.

Superpave Gyratory, 230V 50/60Hz HA-5950.4F

Ship wt. 529lbs. (240kg)



Compact, Hydraulic Steel Roller Compactor

ASTM D8079, EN 12697-33

The Roller Compactor is considered to be the method of laboratory specimen compaction that results in slabs of asphaltic paving materials with properties that most closely simulate those of materials in the highway. Slabs can be compacted to target mixture densities using loads that are equivalent to those of full-scale compaction equipment.

This compactor is hydraulically powered and controlled by a programmable logic controller (PLC) connected to an HMI (Human Machine Interface), which the operator can use to select the number of passes. A manual pressure control is adjusted to set the required load. The main function of the Compact Steel Roller is to produce slabs for beam fatigue and wheel tracking tests.

Features:

- Steel wheeled roller segments
- Solid machine frame
- Optional heated head for reducing mixture sticking to roller during compaction
- Compaction head option: of 15.7/12.6 x 10.2 inch (400/320 x 260mm) and 15.7/12 x 12 inch (400/305 x 305mm) slabs
- Slab depth from 1.6 to 3.9 inch (40 to 100 mm)
- Slabs can be used as wheel-tracking specimens, and cored to make indirect tensile test specimens or cut into beams for 4-Point Bending Test
- Roller Compactor molds will fit Cox/Cooper Wheel Trackers so that compacted slabs can be wheel-tracked without de-molding
- Maximum compaction load of 30kN (6750lbf) (equivalent to largest on-site static rollers)
- Speed control
- HMI for operator selection of number of passes
- Vibrating roller and heated head option to simulate on-site vibratory rollers.

Steel Roller Compactor, 220V 60Hz HA-5700.2F
 Steel Roller Compactor, 220V 50Hz HA-5700.5F

Ship wt. 79 lbs. (36kg)



HA-5700.2F

Specifications	
Maximum Roller Load	6750 lbf (30kN) over 12" (305mm) roll width
Trolley Travel	±6" (150mm) or ±8" (200mm)
Slab Thickness	1.6" to 3.9" (40 to 100mm)
Electrical Supply	220V 60Hz, 1 Ph
Dimensions	23.6" x 57" x 74.8" (600 x 1450 x 1900mm)
Working Space Required (WxDxH)	63" x 67" x 79" (1600 x 1700 x 2000mm)
Desktop PC	Not required

Accessories	Model
Heated-head option	HA-5700.2
Vibration option to simulate conditions in-situ	HA-5700.7
Stainless steel mold 12.6" x 10.2" x 2.3" (320 x 260 x 60mm) deep	HA-5700.5
Stainless steel mold 15.7" x 10.2" x 4" (400 x 260 x 100mm) deep	HA-5700.6
Steel and aluminum quick release mold for roller compactor or wheel tracker, 15.7" x 10.2" x 2" (400 x 260 x 50mm) deep	HA-5700.3



INSTALLATION

Installation Verification and on-site Training are available for the Gyratory, please inquire.



ACCESSORIES

Accessories, roller heads and molds are not included and should be ordered separately.

* Other mold sizes available, please inquire.





Hand Compactor Set for 4" Molds

ASTM D6926

Compactor set that facilitates hand compaction of 4" Marshall specimens. Set features ASTM-compliant oak pedestal with hammer support rod, which holds hammer in perpendicular alignment to base during compaction. Also features a mold holder, which keeps the mold securely positioned during compaction. Set includes: H-1340G compaction hammer; H-1347 pedestal with ASTM-compliant steel plate; H-1341A compaction mold; H-1343 compaction mold holder; H-1345.6 hammer support rod, and H-1345.5 adjustable guide. Additional mold and hammer assemblies are recommended for efficient testing operations, allowing you to preheat multiple molds and hammers to speed testing.

4" Hand Compactor Set **H-1345**
Ship wt. 165lbs. (74.8kg)

4" Hand Compaction Hammer

AASHTO T245, R68

Hammer used to compact asphalt mixture in the compaction mold. Flat circular face is 3.875" (98mm) dia.; hammer is 10 lb. (4.54kg.), sliding weight and has a free fall of 18" (457mm). Additional mold and hammer assemblies are recommended for efficient testing operations, allowing you to preheat multiple molds and hammers to speed testing.

4" Hand Compaction Hammer **H-1340**
Ship wt. 18.5lbs. (8.3kg)

4" Hand Compaction Hammer w/ Finger Guard

ASTM D6926

Compacts asphalt mixture in the compaction mold. Hammer has finger guard at base of sliding weight. Flat circular face is 3.95" (100.3mm) dia.; hammer is 10 lb. (4.54kg.) sliding weight and has a free fall of 18" (457mm). Additional mold and hammer assemblies are recommended for efficient testing operations, allowing you to heat multiple molds and hammers to speed testing.

4" Hammer w/Finger Guard **H-1340G**
Ship wt. 20lbs. (9.0kg)

Mold Holder for Hand Compaction

ASTM D6926

Holder mounts on compaction pedestal and centers the compaction mold under the hammer for fast, repeatable operation. Mold holder keeps mold, collar and base plate securely positioned during compaction.

Mold Holder for Hand Compaction **H-1343**
Ship wt. 4.8lbs. (2.1kg)

Pedestal for 4" Hand Compactor

ASTM D6926

This oak pedestal is necessary for stabilizing molds during compaction. The ASTM-compliant oak compaction pedestal is 8" x 8" x 18" (203 x 203 x 457mm), capped with 12" x 12" x 1" (305 x 305 x 25mm) steel plate. The pedestal mounts to a concrete slab with four angle brackets located at the bottom of pedestal.

Pedestal for 4" Hand Compactor **H-1347**
Ship wt. 82lbs. (37.1kg)

Hammer Guide, Adjustable

Hammer guide for hand compactor testing.

Hammer Guide, Adjustable **H-1345.5**
Ship wt. 2.6lbs. (1.1kg)

Hammer Support Rod

Hammer support rod for hand compactor testing. Mounts to pedestal.

Hammer Support Rod **H-1345.6**
Ship wt. 9.3lbs. (4.2kg)

Marshall Mix Design and Testing Booklet

This booklet covers the Marshall mix design criteria; equipment necessary to perform the tests; sample preparation and testing procedures; data analysis, as well as moisture susceptibility testing methods.

Marshall Mix Design Booklet **H-1328A**
Ship wt. 9lbs. (4.1kg)

ACCESSORIES

Ovens and hotplates can be used to facilitate the heating of molds and hammers for better testing control. See page 332-337 for ovens and page 339 for hotplates.



Heavy-Duty, Auto Marshall Compactor

ASTM D6926, D5581, AASHTO T245, PTM705, R68 Humboldt automatic, Marshall compaction machines are designed to provide a stable and rigid mechanism for producing 4" or 6" diameter asphalt pills used in Marshall tests. These Marshall compaction machines are available in two types of configurations: one with a rotating mold with a tapered-foot hammer assembly, and the other, a stationary mold with a flat-foot hammer. Both models feature a heavy-duty design, which stands up well to the constant jarring caused by the compaction process.

These machines feature an automatic counter, which allows the operator to preset the number of blows desired and, turns off the machine when a cycle is completed. After the number of blows has been set, the operator can start the machine with a push button and keep track of the number of blows on an LED readout. A cam-action lever operates the integral mold holder to facilitate insertion and removal of the compaction mold.

Machines can be ordered with either 4" or 6" molds, but can easily be altered later to accommodate the other size by purchasing a hammer and test molds of the desired size.

Each machine includes: the mechanical compactor, ASTM-compliant pedestal, an automatic counter and hammer assembly, (1) compaction mold, and (1) package of paper discs. rotating-mold configuration machines come with a tapered-foot hammer assembly and stationary-mold configuration machines come with a flat-foot hammer assembly.

Rotating Mold Configuration

4" Dia. Specimens, 115V 60Hz	H-1364R
6" Dia. Specimens, 115V 60Hz	H-1366R
4" Dia. Specimens, 230V 60Hz	H-1364R.2F
6" Dia. Specimens, 230V 60Hz	H-1366R.2F
4" Dia. Specimens, 230V 50Hz	H-1364R.5F
6" Dia. Specimens, 230V 50Hz	H-1366R.5F

Ship wt. 330lbs. (149.6kg)

Stationary Mold Configuration

4" Dia. Specimens, 115V 60Hz	H-1364
6" Dia. Specimens, 115V 60Hz	H-1366
4" Dia. Specimens, 230V 60Hz	H-1364.2F
6" Dia. Specimens, 230V 60Hz	H-1366.2F
4" Dia. Specimens, 230V 50Hz	H-1364.5F
6" Dia. Specimens, 230V 50Hz	H-1366.5F

Ship wt. 320lbs. (145.15kg)



H-1364R



H-1360A
H-1360AF

H-1360B
H-1360BF



H-1360M



H-1334BA
H-1334BA.4F



ACCESSORIES

Ovens and hotplates can be used to facilitate the heating of molds and hammers for better testing control. See page 332-337 for ovens and page 339 for hotplates.



Replacement Parts for Heavy-Duty Automatic, Single Compactors

Item	Part No.
4" Hammer with tapered foot (rotating mold)	H-1360A
6" Hammer with tapered foot (rotating mold)	H-1360B
4" Hammer with flat foot (stationary mold)	H-1360AF
6" Hammer with flat foot (stationary mold)	H-1360BF
Lift chain for H-1364, H-1366 series compactors	H-1360.21
Replacement ASTM-compliant pedestal for compactors	H-1360M
Replacement counter & proximity switch, 120V	H-1334BA
Replacement counter & proximity switch, 230V	H-1334BA.4F



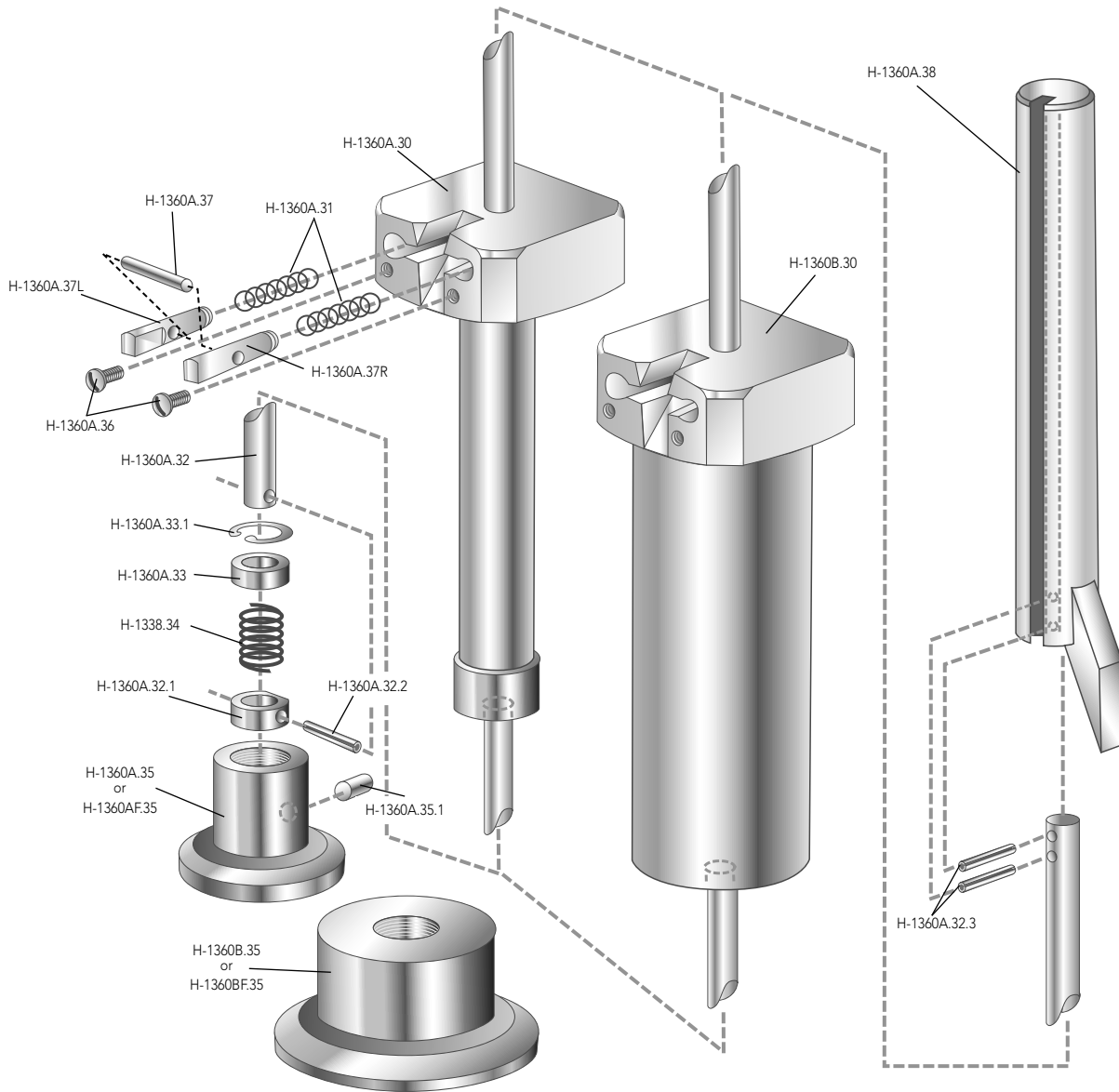

Hammer Assemblies and Replacement Parts

Item	Part No.	Item	Part No.
Sliding weight, 10 lb (for 4" mold)	H-1360A.30	Anvil release arm weldment	H-1360A.38
Sliding weight, 22.5 lb (for 6" mold)	H-1360B.30	Hammer release arm	H-1360A.38.1
Hammer slide shaft	H-1360A.32	Anvil, top	H-1360A.38.2
Spring retainer, anvil	H-1360A.32.1	Spring (Foot)	H-1338.34
Spring washer, anvil	H-1360A.33	Spring (Release)	H-1360A.31
Hammer foot, 4" tapered	H-1360A.35	0.25" dia. x 1" large roll pin	H-1360A.32.2
Hammer foot, 4" flat	H-1360AF.35	0.1875" dia. x 1.5" roll pin	H-1360A.32.3
Hammer foot, 6" tapered	H-1360B.35	Internal retaining ring	H-1360A.33.1
Hammer foot, 6" flat	H-1360BF.35	0.3125" dia x 0.5" large dowel pin	H-1360A.35.1
Hammer release pin, left hand	H-1360A.37L	1/4-20 x 1/2" large truss head screw	H-1360A.36
Hammer release pin, right hand	H-1360A.37R	0.25" dia. x 1.375" Large dowel pin	H-1360A.37



H-1336AD

4" Automatic, Single Compactor (64 Blows per min.) with Stationary Base

ASTM D6926, AASHTO T245, PTM705, R68

This compactor automatically compacts samples at a preset number of 64 hammer blows a minute and shuts off at completion. The compactor features a stationary base with flat-foot hammer. Unit includes mechanical compactor, automatic counter, ASTM-compliant oak compaction pedestal, (1) hammer and (1) H-1341A mold assembly. Additional mold and hammer assemblies are recommended for efficient testing operations, allowing you to preheat multiple molds and hammers to speed testing.

- 4" Single Compactor, 115V 60Hz H-1336AD
 - 4" Single Compactor, 230V 60Hz H-1336AD.2F
 - 4" Single Compactor, 230V 50Hz H-1336AD.5F
- Ship wt. 226lbs. (102.5kg)

4" Automatic, Single Compactor (55 Blows per min.) with Stationary Base

ASTM D6926, AASHTO T245, PTM705, R68

This compactor automatically compacts samples at a preset number of 55 hammer blows a minute and shuts off at completion. The compactor features a stationary base with flat-foot hammer. Unit includes mechanical compactor, automatic counter, ASTM-compliant oak compaction pedestal, (1) hammer and (1) H-1341A mold assembly. Additional mold and hammer assemblies are recommended for efficient testing operations, allowing you to preheat multiple molds and hammers to speed testing.

- 4" Single Compactor, 115V 60Hz H-1336BD
 - 4" Single Compactor, 230V 60Hz H-1336BD.2F
 - 4" Single Compactor, 230V 50Hz H-1336BD.5F
- Ship wt. 226lbs. (102.5kg)



H-1346D

4" Automatic, Double Compactor with Rotating Base

ASTM D6926, AASHTO T245, PTM705

This compactor automatically compacts two samples simultaneously at a preset number of hammer blows and shuts off at completion. The compactor features rotating bases with tapered-foot hammers. Unit includes mechanical compactor, automatic counter, ASTM-compliant oak compaction pedestal, (2) hammers and (2) H-1337 mold assemblies. Additional mold and hammer assemblies are recommended for efficient testing operations, allowing you to preheat multiple molds and hammers to speed testing.

- 4" Double Compactor, 115V 60Hz H-1346D
 - 4" Double Compactor, 230V 60Hz H-1346D.2F
 - 4" Double Compactor, 230V 50Hz H-1346D.5F
- Ship wt. 265lbs. (120.2kg)



H-1356D

4" Automatic, Triple Compactor with Rotating Base

ASTM D6926, AASHTO T245, PTM705

This compactor automatically compacts three samples simultaneously at a preset number of hammer blows and shuts off at completion. The compactor features rotating bases with tapered-foot hammers. Unit includes mechanical compactor, automatic counter, ASTM-compliant oak compaction pedestal, (3) hammers and (3) H-1337 mold assemblies. Additional mold and hammer assemblies are recommended for efficient testing operations, allowing you to heat multiple molds and hammers to speed testing.

- 4" Triple Compactor, 115V 60Hz H-1356D
 - 4" Triple Compactor, 230V 60Hz H-1356D.2F
 - 4" Triple Compactor, 230V 50Hz H-1356D.5F
- Ship wt. 351lbs. (181.4kg)

Replacement Parts for Standard-Duty, Automatic Compactors

Item	Model #
4" hammer with flat foot (stationary base) for H-1336D	H-1338A
4" hammer with tapered foot (rotating base) for H-1346D, H-1356D	H-1338B
4" hammer with "Canadian" tapered foot (rotating base) for H-1346D, H-1356D	H-1338C
Marshall Compaction Mold 4" for Stationary Base Compactors	H-1341A
Marshall Compaction Mold 4" for Rotating Base Compactors	H-1337
Lift Chain for H-1336D, H-1346D and H-1356D	H-1336.21
Replacement Counter and proximity switch for Compactors, 115V	H-1334B
Replacement Counter and proximity switch for Compactors, 230V	H-1334B.4F
Replacement Pedestal for H-1336D Marshall Compactor	H-1347M
Replacement Pedestal for H-1346D Marshall Compactor	H-1347.2M
Replacement Pedestal for H-1356D Marshall Compactor	H-1347.3M



Lift Catch Assembly and Replacement Parts

Item	Model #
Complete lift catch assembly	H-1338.40A
Release block	H-1338.28
Pin	H-1338.28.1
Clevis pin	H-1338.29
Lift catch	H-1338.30
Spring	H-1338.31
Screw	H-1338.36
Washer	H-1338.37
Release housing	H-1338.40
Screw for release housing	H-1338.40.1

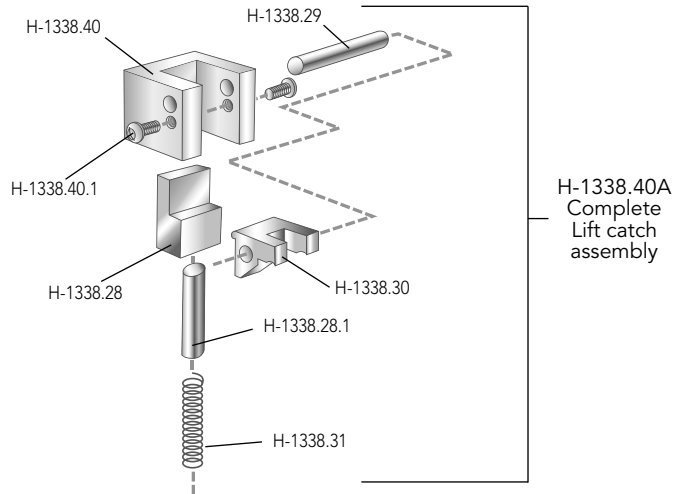

Hammer Assemblies and Replacement Parts

Item	Model #
Clevis pin with screw	H-1338.29
Locator guide	H-1338.25
Hex head bolt	H-1338.25.1
Washer	H-1338.25.2
Nut	H-1338.25.3
Spacer	H-1338.25.4
Hammer handle	H-1338.26
Spring pin	H-1338.26.1
Hammer rod	H-1338.27
Key	H-1338.27.1
Hammer weight (complete)	H-1338.32
Plug	H-1338.33
Spring	H-1338.34
Hammer foot, flat	H-1338.35
Hammer foot, tapered	H-1338.38
Hammer foot, Canadian spec	H-1338.39
Screw for foot (2 required)	H-1338.35.1
Socket Head Screw, 5/16 x 18 x 1.25"	H-1338.36
Washer	H-1338.37

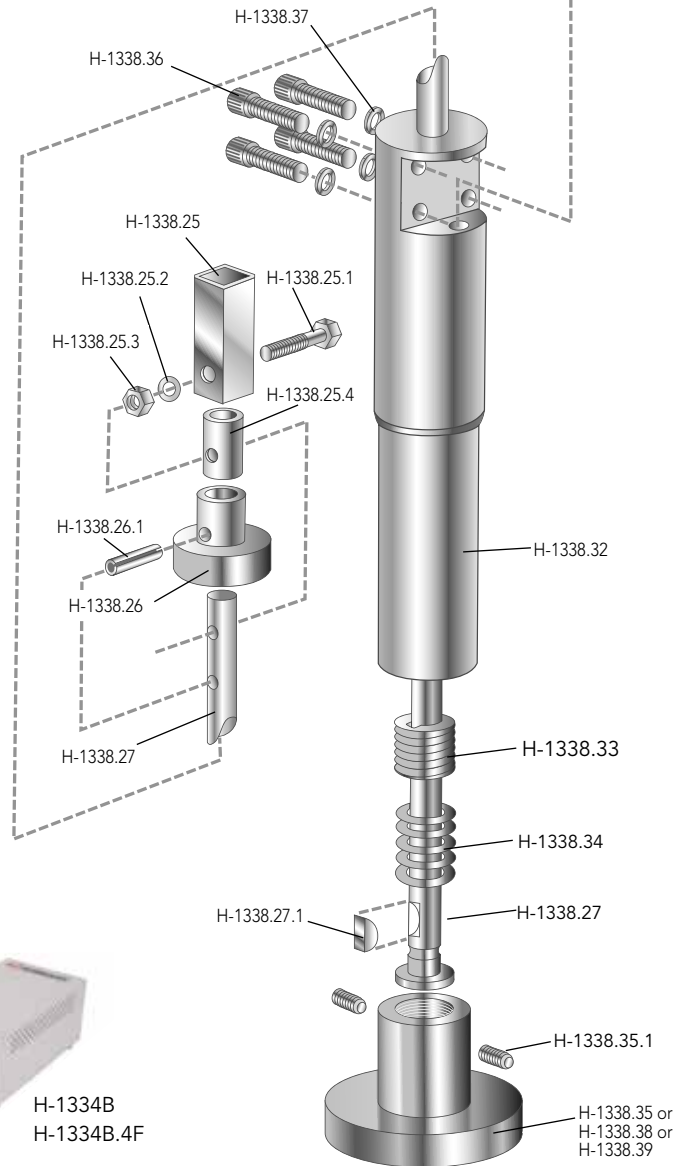

H-1338A
H-1338B
H-1338C



H-1347M



H-1334B
H-1334B.4F



ACCESSORIES

To facilitate the heating of molds and hammers, See page 332-337 for Ovens and page 339 for Hotplates.



Marshall Compaction Mold, 6" or 150mm
ASTM D5581

6" or 150mm compaction mold assembly for preparing test specimens with the H-1366 and H-1366R compactors. Can be used with rotating or stationary base models. Mold is machined from seamless tubing and plated. Mold is comprised of a base plate, mold cylinder and extension collar.

Compaction Mold, 6" H-1367
Compaction Mold, 150mm H-1367MM
Ship wt. 15lbs. (6.8kg)

Marshall Compaction Mold, 4" (Rotating Base)
ASTM D6926

4" compaction mold assembly for preparing test specimens with the H-1364R rotating base compactors. Mold is machined from seamless tubing and plated. Mold is comprised of a base plate, mold cylinder and extension collar.

Compaction Mold, 4" H-1361
Ship wt. 9lbs. (4kg)

Marshall Compaction Mold, 4" (Stationary Base)
ASTM D6926

4" compaction mold assembly for preparing test specimens with H-1336D mechanical compactor and H-1340 and H-1345 hand compactors. Mold is machined from seamless tubing and plated. Mold is comprised of a base plate, mold cylinder and extension collar. Base plate and collar are interchangeable with either end of the forming mold. Forming mold is 4" (102mm) ID by 3" (76mm) high.

Compaction Mold, 4" (Stationary Base) H-1341A
Ship wt. 8lbs. (3.6kg)

Marshall Compaction Mold, 4" or 100mm (Rotating Base)

4" or 100mm compaction mold assembly for preparing test specimens with the H-1346D and H-1356D rotating-base compactors. The mold is machined from seamless tubing and plated. Mold is comprised of a base plate, mold cylinder and extension collar. Base plate of mold is designed to link with rotating base feature of compactors causing the mold to rotate during compaction. Forming mold is 4" (102mm) ID by 3" (76mm) high and interchangeable with either end of the forming mold. Forming mold is 4" (102mm) ID by 3" (76mm) high.

Compaction Mold, 4" (Rotating Base) H-1337
Compaction Mold, 100mm (Rotating Base) H-1337MM
Ship wt. 8lbs. (4kg)

Paper Disks
ASTM D5581, D6926

Circular, smooth-edged 4" or 6" diameter disks, which can be placed in the bottom of compaction molds prior to filling with asphalt mixture to facilitate removal of the sample from the mold. Use with all molds.

Paper Disks, 4" package of 1000 H-1341P
Paper Disks, 6" package of 500 H-1361P
Ship wt. 0.8lbs. (0.3kg)

Mold Extractors
ASTM D5581, D6926, AASHTO T245, R68

Used with compression tester for removing 4" or 6" specimens from compaction molds.

Mold Extractor, 4" H-1348
Mold Extractor, 6" H-1363
Ship wt. 3.6lbs. (1.6kg)

Storage Can for Marshall Samples

4" dia. x 5.5" tall metal can with lid for storing Marshall mix samples.

Storage Can, 4" H-1331
Ship wt. 2.8lb. (1.27kg)

Sample Ejector, Hand-Operated

ASTM D5581, D6926, AASHTO T245, R68

Designed for lab and field use to extract asphalt samples from either 4" or 6" compaction molds. The ejection force is generated by means of a 3-ton (27.7kN) capacity hand-operated hydraulic jack. The cast-aluminum ejector head assembly can be positioned at different heights through the use of quick release pins. This enables the operator to easily match the ejection travel to the height of the mold being used. Maximum stroke distance for this ejector is 7.5". Overall dimensions: 13"W x 6"D x 27"H (330 x 152 x 686mm).

Sample Ejector, Hand-Operated H-1353A
Ship wt. 46.2bs. (20.9kg)

Sample Ejector, Motorized

ASTM D5581, D6926, AASHTO T245, R68

Similar in design and construction to the H-1353A series sample ejector, this model features the use of a 5-ton capacity motorized hydraulic pump and ram assembly. The unit incorporates extended upright rods in order to accommodate both standard 4" or 6" asphalt compaction molds, as well as the taller gyratory compaction molds. Maximum stroke distance for this ejector is 9.25". Overall dimensions excluding pump: 13"W x 6"D x 29"H (330 x 152 x 737mm).

Sample Ejector, 120V 60Hz H-1355
Sample Ejector, 220V 50/60Hz H-1355.4F
Ship wt. 81lbs. (36.7kg)



H-1394



H-1392, H-1390



H-1380

- Auto-tuning is fast & effortless
- Rapid cycling provides fast system response
- Dual, digital display simultaneously shows set point and process temperature
- Ramp-to-set point handles critical temperature processes smoothly
- Set point range limiting protects process and equipment
- Percent power limit protects components from stress.
- Operator lockout guards against unwanted changes
- All exposed parts are stainless steel. Front panel is water and corrosion resistant.

Humboldt water baths feature a microprocessor-based digital controller for precise temperature control throughout their temperature range of ambient to 180°F (82°C) at an accuracy of +/-0.1% of input span. The dual digital display simultaneously shows the set point and the process temperature at a glance.

Humboldt water baths are fully insulated to help maintain constant temperatures easily. Models H-1390 and H-1392 can accommodate (12) 4" diameter or (3) 6" diameter Marshall specimens at a time. And the model H-1394 can accommodate (16) 4" and (9) 6" diameter Marshall specimens at a time. All models include a stainless steel shelf, which supports specimens while allowing 2" of free circulating water above and below specimens. Models H-1390 and H-1394 also utilize a magnetic stirring bar to induce water flow within the bath and ensure a uniform temperature is maintained. Model H-1392 does not have a magnetic stirring bar. All exposed areas are stainless steel and the front control panel is both water and corrosion resistant.

Deluxe Water Bath

ASTM D6927, D5581 and D4867

Microprocessor-based control for precise temperatures throughout the range. Includes magnetic circulator, ensuring constant water temperature, and, a stainless steel shelf, which stands 2" (51mm) above the bottom of the unit for free circulation of water above and below test samples. Volume is 7.76 gallons (29.40L) and dimensions are: ID: 19.5" W x 11.5" D x 8" H (495.3 x 292.1 x 203.2mm).

Water Bath, Deluxe 120V 60Hz H-1390
 Water Bath, Deluxe 220V 50/60Hz H-1390.4F

Ship wt. 44lbs. (19.9kg)

Water Bath

ASTM D6927, D5581 and D4867

Microprocessor-based control for precise temperatures throughout the range. Includes a stainless steel shelf, which stands 2" (51mm) above the bottom of the unit for free circulation of water above and below test samples. Volume is 7.76 gallons (29.40L) and dimensions are: ID: 19.5" W x 11.5" D x 8" H (495.3 x 292.1 x 203.2mm).

Water Bath, 120V 60Hz H-1392
 Water Bath, 220V 50/60Hz H-1392.4F

Ship wt. 43lbs. (19.5kg)

Large Deluxe Water Bath

ASTM D6927, D5581 and D4867

Microprocessor-based control for precise temperatures throughout the range. Includes magnetic circulator, ensuring constant water temperature, and, a stainless steel shelf, which stands 2" (51mm) above the bottom of the unit for free circulation of water above and below test samples. Volume is: 17 gallons (63.4L) and dimensions are 20" x 20" x 10" deep (508 x 508 x 254mm).

Water Bath, Large 120V 60Hz H-1394
 Water Bath, Large 220V 50/60Hz H-1394.4F

Ship wt. 75lbs. (34kg)

Economy Water Bath

Low-cost alternative water bath for heating specimens holds eight standard 4" stability molds. Supporting shelf above the bottom allows water circulation around specimens. Automatic thermostat control with a range of 150° to 500°F (65° to 160°C). ID 11.5 x 19.5 x 5.5" (293 x 497 x 140mm) deep. H-1380.4F uses a step-down transformer, which is included, for electric conversion.

Water Bath, Economy 120V 60Hz H-1380
 Water Bath, Economy 220V 50/60Hz H-1380.4F

Ship wt. 18lbs. (8.16kg)



ELITE SERIES Load Frames



HM-5120.3F

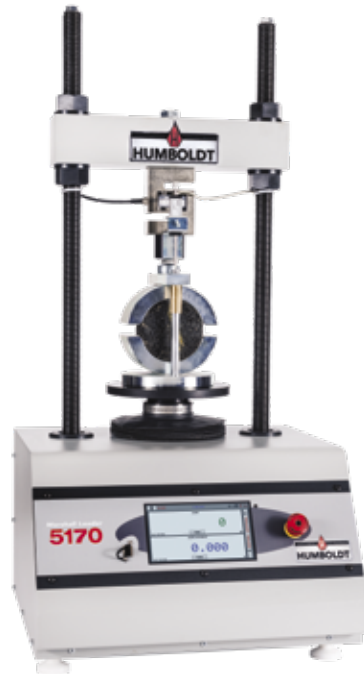

HM-5170.3F

NOTES

HM-5120.3F and HM-5170.3F Load Frames are sold as a load frames only. (shown with typical Marshall setup)

Marshall, TSR, SCB Load Frames

ASTM D5581, D6926, D6931; AASHTO T245, T283; BS 598; EN12697-34

Humboldt provides these two Elite Series Load Frames for doing Marshall, TSR and SCB testing. The two machines are identical except that the HM-5170 can also do CBR soil testing.

The HM-5120 and HM-5170 Load Frames have been specifically designed to handle Marshall, TSR and SCB applications. Their heavy-duty design and precise stepper-motor control provide a stable platform for years of reliable service. From educational institutions and consulting firms to high-volume commercial labs and construction projects, the Load Frames can perform these applications with ease.

The HM-5120 and HM-5170 are built around Humboldt's integral, data logger with touch-screen control, which allows the load frames to be used as standalone devices capable of full test control and data logging.

It is recommended that users operate the testing procedure from the front panel of the load frame, since Marshall testing is such a short, time-sensitive test. The waterproof, touch screens featured on these load frames provide a colorful, at-a-glance monitoring

of testing functions without the use of a computer. Operators can see all the data in several formats at the machine during the testing procedure. Test data can then be transferred to a computer for use with Humboldt's NEXT Software for report generation. A Marshall-specific software module is also available for use with the NEXT software, which provides Marshall-specific setup and formatting, rather than the generic formatting provided with the basic NEXT software.

Standalone Control

Touch-Screen Controller provides:

- Multi-channel data acquisition
- Hi-res, 7", waterproof, touch-screen provides total control and real-time graphical display of tests
- Machine/Test control and data acquisition via touch-screen
- Calibration of channels to load cell and transducer
- Real-time graphical chart and numerical display of tests via touch-screen display
- Effective sampling rate of 50 readings per second
- Stores up to 1000 tests with 3000 points per test
- 2 USB ports. One in front for data transfer and the rear port is for powering a wireless access point.

Humboldt's NEXT software is included with all Elite Series Load Frames. In the case of the HM-5120 and HM-5170 for use with Marshall testing, it is recommended this software be used for data acquisition and report generation only and not for control of the machine. In this appli-

cation the NEXT software can provide advanced graphing capabilities, full-unit customization and reports can also be exported to Excel or a CSV file.

HM-5120 and HM-5170 Specifications

Load capacity	11000 lbf (50kN)
Speed range	2 in/min. 50.8mm/min.
Data channels	2
Platen Size / Travel	10" (254mm) / 4" (100mm)
Data storage	1000 tests and up to 3000 readings per test
Clearance, vertical	40" (1000mm)
Clearance, horiz.	15" (380mm)
Voltage	110/220V 50/60Hz. 5.0amps

The HM-5120 and HM-5170 load frames are sold as a Load Frame ONLY, refer to the recommended accessories chart for items needed to perform specific tests.

Marshall Load Frame, 110/220V 50/60 Hz HM-5120.3F

Shipping wt. 300 lb (136kg)

Marshall CBR/LBR Frame, 110/220V 50/60 Hz HM-5170.3F

Shipping wt. 300 lbs (136kg)

Humboldt MasterLoader Marshall Solution

ASTM D5581, D6926, D6931; AASHTO T245, T283; BS 598; EN12697-34

The HM-5030 Master Loader provides the ultimate solution for a lab looking to perform Marshall, Hveem and SCB testing, but would also like to be able to use the load frame for all their other testing needs as well. The digital MasterLoader provides that ability by easily handling asphalt compression testing, as well as soil tests such as CBR and triaxial tests including UU, CU, CD and UC.

The digital MasterLoader has the ability to work as a stand-alone unit, which can perform Marshall tests at the push of a button; or in conjunction with Humboldt's NEXT software, the Marshall software module and a computer, it can gather data in real-time data acquisition in the form of charts and graphs. The HM-5030 is ideal for road construction projects in either mobile or fixed labs, educational institutions and consulting firms.

Designed for applications requiring multi-purpose loading systems, such as road construction projects in either mobile or fixed labs, educational institutions and consulting firms, the HM-5030 Master Loader is ideal for just about any application from road construction to high-volume commercial and educational laboratories.

While the HM-5030 has been specifically designed for soil testing labs conducting multiple testing operations including: UU, CU and CD triaxial, UC, CBR and LBR, it is also perfect for running Marshall, Hveem, TSR and SCB asphalt tests as well. Its heavy-duty design and precise stepper-motor control provide a stable platform for years of reliable service allowing the HM-5030 to perform any tests required up to its load capacity of 11000 lbf (50kN).

Like all Elite Series load frames, the HM-5030 is built around Humboldt's integral, 4-channel data logger with touch-screen control, which allows the load frame to be used as a standalone device capable of full test control and data logging. It can also be controlled by a networked computer at any location with access to the network.

HM-5030.3F Specifications	
Load capacity	11000 lbf (50kN)
Speed Range Testing:	0.00001 – 2.00000 in/min (0.00001 – 50.80000 mm/min)
Fast Approach:	3.0 in/min (75.0 mm/min)
Data channels	4
Platen Size / Travel	10" (254mm) / 4" (100mm)
Data storage	1000 tests and up to 3000 readings per test
Clearance, vertical	40" (1000mm)
Clearance, horiz.	15" (380mm)
Voltage	110/220V 50/60Hz. 5.0 amps

Master Loader, 110/220V 50/60 Hz **HM-5030.3F**
Shipping wt. 300 lb (136kg)



HM-5030.3F

Recommended Marshall, TSR and SCB Accessories for use with HM-5030, HM-5120 and HM-5170 Load Frames

Marshall, TSR & SCB Accessories	
Part #	Description
HM-2300.100	S-type load cell, 11,000lbf (50kN)
HM-2310.10	Strain Transducer, 1" (25mm)
HM-2305.10	Strain Transducer, 1" (25mm) Required for HM-5120-5170 ONLY.
HM-4178BRT	Displacement transducer bracket
HM-2305BRSQ	Displacement transducer bracket Required for HM-5120-5170 ONLY.
HM-5005SW	Marshall software module
H-1342	Marshall breaking head, 4"
H-1362	Marshall breaking head, 6"
H-1349	Lottman breaking head, 4"
H-1369	Lottman breaking head, 6"
H-1351	Semi-circular Bend Test Breaking Head



NOTES

HM-5030.3F Load Frame is sold as a load frame only. (shown with typical Marshall setup)

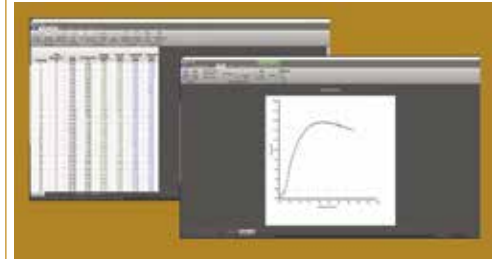

NEXT Marshall Software Module

ASTM D5581, D6926, D6931; AASHTO T245, T283; BS 598; EN12697-34

Humboldt's NEXT software is used to control the operation of Humboldt's testing machines, as well as provide data acquisition and reporting of test data. The software provides a computer-based platform with the ability to configure testing machines and the testing process, specify testing parameters and limits, operate the machine during the testing and provide detailed reports of the data collected in tabular or graphical formats.

Humboldt's NEXT data acquisition software, in conjunction with compatible Humboldt testing equipment, provides a complete solution for the acquisition, recording and presentation of test data.

The Marshall-specific Module provides these added features to the NEXT software.

- Marshall-specific setup, which guides you through the process and includes selecting data collection parameters that best fit the Marshall test
- Input specific project information for each test, such as project name, client information, etc
- All Marshall-specific initial, intermediate, and final parameters required by ASTM and BS standards are dynamically calculated for you, based on your input of specimen information, such as size, weight, etc
- Tabulated test data, graphs and all Marshall-specific calculations are provided in real time, allowing you to monitor tests in process
- Generate Marshall-specific reports that include all graphs and data presented in a project

NEXT Marshall Software Module **HM-5005SW**

Download from Humboldt website





HM-2850.3F



H-1339B



H-1335
Marshall Test Set

Multi-Speed Load Frame

ASTM D5581, D6926, D6931, AASHTO T245, T283, BS 598, EN12697-34

The HM-2850 Multi-speed Load Frame is designed for those who want a high-quality, but simple, multi-purpose load frame without built-in data acquisition capabilities. The HM-2850 is ideal for applications where the operator is either not concerned with data acquisition; or, already has or is planning to construct their own data acquisition system. With its large 7" color, touchscreen, the HM-2850 provides the operator with the ability to precisely select any speed with four-decimal accuracy within the machine's speed range.

The HM-2850 features a quiet, direct drive stepper motor that provides a range of loading speeds from .00001 to 2.00000 in/min. This speed range is more than adequate for the majority of standard soil tests. The HM-2850 also incorporates a separate, dedicated control to accommodate 2.00 in/min. for use in Marshall and TSR Testing, as well as a rapid travel speed of 2.25 in/min for moving the platen into position quickly. Speeds are controlled through the use of edit keys and the digital display.

Specifications	
Load capacity	11000 lbf (50kN)
Speed range	.00001 - 2.00000 in/min. .00001 - 50.80000 mm/min.
Platen Size / Travel	8" (203mm) / 3" (76mm)
Clearance, vertical	40" (812mm)
Clearance, horiz.	11" (279mm)
Dimensions (l x w x h)	17 x 22 x 51 inch (432 x 559 x 1295mm)
Voltage	110/220V 50/60Hz. 5.0 amps

Multi-Speed Load Frame, 110/220V 50/60 Hz HM-2850.3F
Shipping wt. 300 lb (136kg)

Marshall Compression Machine

ASTM D5581, D6926, D6931, AASHTO T245, T283, BS 598, EN12697-34

Compression machine designed specifically for testing the resistance to plastic flow of bituminous paving mixtures—the Marshall test. Machine has a one-speed motor with reversing switch that produces a uniform vertical movement of 2" (51mm) per minute. Unit includes a H-4454.100 calibrated load ring and dial indicator for determining test load. Load capacity is 11,000 lbf. (50kN). Maximum piston travel is 3.5" (88mm). Overall dimensions are: 18" x 18" x 38.5"H (457 x 457 x 978mm).

Compression Machine, 120V 60Hz	H-1339B
Compression Machine, 220V 60Hz	H-1339B.2F
Compression Machine, 220V 50Hz	H-1339B.5F
Ship wt. 250lbs. (113.3kg)	

Basic Marshall Test Set

ASTM D5581, D6926, D6931, AASHTO T245, T283, BS 598, EN12697-34

Basic test set for evaluating stability and plastic flow (Marshall tests) of bituminous paving mixtures. Includes all the basic testing equipment for performing these tests. Ideal setup for field lab applications, as well as dedicated Marshall test labs. Included in the set are: (1) H-1339B—Marshall compression machine; (1) H-1340— 4" hand compaction hammer; (2) H-1341A— 4" Marshall compaction molds; (1) H-1342—4" Marshall breaking head; (1) H-1343— mold holder for hand compactor; (1) H-1344— dial flowmeter with guide sleeve; (1) H-1347— pedestal for 4" hand compactor; (1) H-1348— 4" mold extractor, and (1) H-1390— water bath. 230V models include a H-1390.4F water bath.

Metric version includes: (1) H-1339B, 220V Marshall compression machine; (1) H-1340— 4" hand compaction hammer; (2) H-1341A— 4" Marshall compaction molds; (1) H-1342M—100mm Marshall breaking head; (1) H-1343— mold holder for hand compactor; (1) H-1344.2M— dial flowmeter with H-1390, 230V water bath.

Marshall Test Set, 120V 60Hz	H-1335
Marshall Test Set, 220V 60Hz	H-1335.2F
Marshall Test Set, 220V 50Hz	H-1335.5F
Marshall Test Set-Metric, 230V 60Hz	H-1335M.2F
Marshall Test Set-Metric, 230V 50Hz	H-1335M.5F
Ship wt. 325lbs. (147.4kg)	

Typical Setup for Marshall Testing with HM-2850 or H-1339B Load Frames

Description	Qty	Part #
Marshall load frame (choose one)	1	H-1339B HM-2850
Load Ring, 11,000 lbf (50kN)	1	H-4454.100
Dial flow meter kit w/ Dial gauge 1.00" x 0.01 "	1	H-1344
Marshall breaking head, 4"	1	H-1342





H-1342, H-1362
H-1342M

H-1349, H-1369
H-1349M, H-1369M



H-1351



HA-1343, HA-1343M

H-1344.2

H-1344

Marshall Breaking Head,
ASTM D6927

Marshall breaking heads consist of an upper and lower cylindrical segment having 3" inside radius of curvature for 6" samples and 2" for a 4" sample. The lower segment is mounted on a base with two perpendicular guide rods extending vertically from the base. One guide rod is larger than the other, with a correspondingly larger guide sleeve in the upper segment to ensure correct assembly. Guide sleeves in the upper segment bring the two sections together without appreciable binding or loose motion on the guide rods.

Marshall Breaking Head, 4"	H-1342
Marshall Breaking Head, 6"	H-1362
	Ship wt. 25lbs. (11.3kg)

Marshall Breaking Head, Metric

Marshall breaking heads consist of an upper and lower cylindrical segment. The lower segment is mounted on a base with two perpendicular guide rods extending vertically from the base. One guide rod is larger than the other, with a correspondingly larger guide sleeve in the upper segment to ensure correct assembly. Guide sleeves in the upper segment bring the two sections together without appreciable binding or loose motion on the guide rods.

Marshall Breaking Head, 100mm	H-1342M
	Ship wt. 25lbs. (11.3kg)

Lottman Breaking Head

ASTM D6931, AASHTO T283

Breaking heads for testing tensile strength. H-1349 has 0.5" wide upper and lower segments for use on 4" samples. H-1369 has 0.75" wide upper and lower segments for use on 6" samples.

Lottman Breaking Head, 4"	H-1349
Lottman Breaking Head, 6"	H-1369
Lottman Breaking Head, 100mm	H-1349M
Lottman Breaking Head, 150mm	H-1369M
	Ship wt. 10.2lbs. (4.6kg)

Semi-Circular Bending (SCB) Head
ASTM D8044; AASHTO TP124

The H-1351 Semicircular Bend fixture has been designed for use with the test methods above. The H-1351 SCB head can be configured in two ways. The first utilizes the upper and lower segments of the breaking head. The lower segment is comprised of a base with two perpendicular guide rods extending vertically and an upper segment mounted to the lower segment by sliding on the vertical guide rods. The holes in the upper segment are lined with brass to reduce binding as it moves up and down the guide rods. In this configuration the upper swivel contact bar is mounted to the upper breaking head segment.

In the second configuration, the upper swivel contact bar is separated from the upper breaking head bar and is mounted directly to the load cell. If using this method, precise alignment can be achieved by using the alignment guide, which is included.

The H-1351 Semi-circular Bending Head can be used in conjunction with one of Humboldt's load frames, such as the HM-5030 Master Loader or HM-5120 Marshall frames. It may also be used with your present load frame, if the frame meets the test's speed requirements. Humboldt offers additional Data Loggers with instrumentation for data acquisition of the SCB test results using the SCB breaking head when used with your present load frame.

Semi-Circular Bending (SCB) Head	H-1351
	Ship wt. 25lbs. (11.3kg)

Asphalt Tack Bond Shear Strength Apparatus
AASHTO T-114

The Asphalt Tack Bond Shear Strength Apparatus is used in a Marshall Stability Test Load Frame to measure shear strength of tack coat material between two asphalt layers. The heavy steel frame holds fixed and moveable shear plates. The moveable plate is centered over the shear plane and features roller bearings to minimize drag. Lateral load on the specimen is controlled by a calibrated spring and a dial indicator displays force. The shear plane gap is 0.5" (12.5mm), and maximum shear travel is also 0.5" (12.5 mm). Adapters are included for testing either 4" (102mm) or 6" (152mm)

diameter samples. The Tack Bond Shear Strength Apparatus is compatible Marshall Load Frames with daylight openings of at least 10" (254mm). The HA-1343 Asphalt Tack Bond Shear Strength Apparatus tests 4" (102mm) and 6" (152mm) Marshall samples. The HA-1343M Asphalt Tack Bond Shear Strength Apparatus accommodates testing of 100mm and 150mm Marshall specimens.

Tack Bond Shear Strength Apparatus	HA-1343
Tack Bond Shear Strength App. Metric	HA-1343M
	Ship wt. 40lbs. (18.1kg)

Dial Flowmeter Kit
ASTM D6927

Used to measure flow during Marshall testing. Consists of a special dial indicator with a maximum position brake assembly and a guide sleeve, which fits over either guide rod of a H-1342 or H-1362 Marshall breaking head. H-1344 has a range of 1.00" with 0.01" divisions and the H-1344M has a range of 25mm with 0.25mm divisions

Dial Flowmeter Kit	H-1344
Dial Flowmeter Kit, Metric	H-1344M
	Ship wt. 2lbs. (.9kg)

Dial Gauge For Flowmeter
ASTM D6927

Consists of a special dial indicator with a maximum position brake assembly. The H-1344 has a range of 1.00" with 0.01" divisions and the H-1344M has a range of 25mm with 0.25mm divisions

Dial Gauge For Flowmeter	H-1344.2
Dial Gauge For Flowmeter, Metric	H-1344.2M
	Ship wt. 1lbs. (.45kg)

Guide Sleeve For Flowmeter Kit
ASTM D6927

Guide sleeve for use with dial gauge to measure flow during Marshall testing. Device fits over either guide rod of a H-1342 or H-1362 Marshall breaking head and provides mounting of dial gauge.

Guide Sleeve For Flowmeter Kit	H-1344.1
	Ship wt. 0.6lbs. (.27kg)



Nuclear Gauges

Choose from Two, High-Quality Gauge Models



HS-5001SD

HS-5001EZ

www.humboldtscientific.com

see pages 6-12 for more information

All Humboldt nuclear gauges are built rugged for the day-to-day rigors of construction projects. These gauges are built to last using high-quality Noryl® PPO material, which is one of the most dimensionally stable thermoplastics available. This produces a gauge housing that is less brittle than the competition resulting in less breakage. Humboldt gauges also pay strict attention to sealing the gauges against dirt and dust, providing a better design and less electronic problems due to dust.

Humboldt gauges are also "Field Serviceable". If you have a problem with your Humboldt gauge, chances are we can quickly get a part out to you, which you can install on your own, saving you lots of time and money. Other manufacturers require you to send your gauge back to the factory for

calibration. We don't. You can send your gauge back to us or you can allow a third party to calibrate your gauge without incurring any charges from Humboldt.

With Humboldt, you get:

- High-quality gauges, built to take a beating
- Truly, field serviceable with parts readily available
- Third-party calibration with no added costs
- Exceptional calibration, leak test and repair service

Humboldt nuclear gauges are available in two models: the SD and EZ Gauges. The SD Gauge, which provides more efficient operation, data collection and processing than any other gauge in its class. Using state-of-the-art technology, the SD gauge brings you a host of features aimed at making your job easier. Featuring a 4.3" touch-screen,

the SD Gauge provides intuitive operation of all gauge operations. It also provides touch pad operation as an alternative control method.

Our EZ gauge is just rugged. It's been used for years in many tough and demanding applications. It has always proven to be easy-to-operate, easy-to-power and easy-to-service. The EZ gauge features a menu-driven control panel with easy-to-use, built-in test routines and auto features, making testing a quick and accurate operation. It also features our innovative trigger release handle that eliminates pinched fingers while providing smooth operation. Unlike some competitors, all Humboldt nuclear gauges are manufactured with 100% new parts — no refurbished gauges sold as new.



Humboldt Pavement Scanner

Humboldt Pavement Scanner with both radar compaction and infrared temperature sensors. No nuclear sources needed. Generates maps of asphalt compaction and temperature.

The Humboldt Pavement Scanner measures asphalt pavement density using advanced radar technology without using nuclear sources. The radar sensor continuously scans the surface to produce compaction or density maps. Additionally, an integrated temperature sensor generates pavement temperature maps. Temperature differences indicate locations where the asphalt mix is not uniform in terms of temperature or mix (i.e., too little binder, different aggregate, etc.). Cold zones and improperly compacted zones lead to premature failure of the mat.

Data Visualization

The Pavement Scanner produces two-dimensional maps of the work area rather than a handful of measurements at specific locations. These maps of compaction and temperature provide much more information than the spot measurements of traditional density gauges. The scanner has an integrated GPS so that these compaction and temperature data can be exported into Google maps and sent to any smart device (cell phone or tablet) for viewing. The ability to view information in map

for provides much better coverage, fast and easy interpretation, better Q/A and Q/C, and ultimately reduced costs.

A Better Alternative

The Pavement Scanner does not use any nuclear sources and does not emit dangerous radiation. Costs and risks associated nuclear sources are eliminated. No more nuclear safety training classes. No more source licensing headaches. The pavement scanner has been designed for high reliability and to be easy to use. All cabling has been eliminated to improve ease of use, and end common problems associated with connectors and cables.

What the Researchers are Saying

When laying down an asphalt mat, research has shown that cold spots are not compacted properly. The IR temperature sensor clearly delineates these zones. Compaction measurements from the radar sensor can be made even after the mat has cooled. The Transportation Research Board has published a detailed study that illustrates the use of these instruments: Using Infrared and High-Speed Ground-Penetrating Radar for Uniformity Measurements on New HMA Layers, TRB, available at: <http://nap.edu/22769>. Complete system includes: 2 GHZ radar antenna, scan cart, tablet and carrying case.

Specifications
2GHz, bi-static radar antenna
Non-contacting IR temperature sensor
Includes rugged IP67 tablet computer
Wifi connection between sensor and tablet
Durable construction with IP65 ingress protection
Positioning system includes odometer, GPS and optional inertial measurements
Provides continuous real-time pavement density and temperature measurements
Generate mpas of pavement density and temperature
Calibrate the unit from core measurements.
Rechargeable LiFePO4 battery provides 5-6 hours of use. Includes second battery for all day use
Dimensions: 71.5" x 25.9" x 36.5"
Shipping dimensions: 29" x 18" x 13.8"

Humboldt Pavement Scanner HHA-6000
Ship wt. 36.4lbs. (16.5kg)





HA-5300A.4F

Hamburg (Immersion) Wheel Tracker

AASHTO T324; EN 12697-22; Various State standards

The Hamburg test, or immersion wheel tracking has become an extremely popular test method over the last few years.

The Hamburg wheel tracker is built to withstand the demands of the busiest test labs. It is made of high quality stainless steel, uses the standard cantilevered arm system of loading the specimens and produces fully sinusoidal motion.

In the NCHRP report - Hamburg Wheel-Track Test Equipment Requirements and Improvements to AASHTO T 324, the Cox/Cooper Hamburg was clearly the best performing machine. Since then the heaters and water flow have been uprated, resulting in more rapid heating and improved temperature control.

A number of Hamburg wheel trackers fall purporting to meet the standard fall short of current AASHTO requirements and may fall further behind when the norm is updated. Please be sure to verify the important parameters in the standard are met by the machine. The Cox/Cooper machine meets all the requirements of the standards.

Features:

- Full super rigid stainless steel construction
- The most rugged, precise and accurate Hamburg wheel tracker available
- Auto arm lift for fully automated test procedure and user safety
- True sinusoidal motion
- Mechanical recirculating water bath for accurate control of the water temperature to better than ± 0.9 °F (0.5 °C).=

- Two displacement transducers with a resolution of 0.01mm, positioned in line with the wheel to ensure accurate measurement of the rut
- Continuous rut and rut profile measurement throughout the test
- Analysis software to automatically pick the inflection point and analyze the output data
- Air hood option for dry tests
- Stainless steel and rubber wheels available
- Built-in timer to start tests automatically
- AASHTO T324, a variety of DOT methods and EN12697-22
- Anytime remote access support
- Quality build in the USA

Software:

- User friendly, intuitive and reliable Windows® software developed using LabVIEW™
- Specifically written to meet AASHTO standards
- The user interface can be translated into the user's preferred language – please inquire
- Stored test data can be analyzed and compared with other test data utilizing a spreadsheet package
- Utilities are included for curve fitting of acquired data; testing of system's inputs and outputs; phase correction and a transducer database for storing calibration factors
- Includes full software control of arms individually at outset and completion of test, with stainless steel frame, includes full software package, traceable calibration certificate and desk PC to perform testing according to AASHTO T324.

Hamburg Wheel Tracker, 220V 50/60Hz HA-5300A.4F
 Hamburg Wheel Tracker, 415V 50/60Hz 3PH HA-5300A.7F

Ship wt. 1520lbs. (687kg)



INSTALLATION

Installation Verification and on-site Training are available for the Gyrotory, please inquire.

Specifications	
Wheel Speed	Variable between 15 and 30 cycles (30 to 60 passes) per minute
Wheel Load	158 ± 1.0lbf (705 ± 4.5N)
Variable Speed Range	15 to 30 RPM
Slab Thickness	2 to 4" (50 to 100mm), different thicknesses can be tested with spacers
Rut Depth Transducer Range	2" (50mm)
Temperature Range	Ambient to 158°F (70°C)
Electrical Supply	220-240V 15 A, 50/60Hz, 1 Ph (single phase with a neutral and ground)
Dimension (W x D x H)	57" x 55" x 50" (1430 x 1380 x 1260mm)
Desktop PC	Included



ACCESSORIES

Accessories are not included and should be ordered separately.

Accessories	Model
Stainless steel molds 12.6" x 10.2" x 2.4" (320 x 260 x 60mm)	HA-5300.1
Plastic mold for double cores 6" tested simultaneously to be inserted in stainless steel mold 12.6" x 10.2" x 2.4" (320 x 260 x 60mm)	HA-5300.5
Stainless steel wheel AASHTO T324-02	HA-5300.6
Rubberized Stainless steel wheel EN 12697-22	HA-5300.7
Powered winch and stainless steel mast	HA-5300.8
Guarding, stainless steel	HA-5300.11
Dry Hood	HA-5300.13

* Other mold sizes available, please inquire.





HA-5600.4F

Specifications	
Maximum force	4946lbf (22kN)
Load transducer	5000lbs (22.2kN)
Maximum displacement	0.2" (5.1mm)
Temperature range	23 to 104°F (-5 to 40°C)
Electrical supply	220V 50/60Hz
Frame dimensions (WxDxH)	62" x 25" x 43" (1580 x 650 x 1100mm)
Working space (WxDxH)	78" x 43" x 43" (2000 x 1100 x 1100mm)
Desktop PC	Not required

INSTALLATION

Installation Verification and on-site Training are available for the Gyrotory, please inquire.

Overlay Tester

ASTM WK26816, Tex-248-F

In recent years many mixture design methods have produced materials that are stiffer, leaner and more resistant to rutting, however, such materials are often more susceptible to fatigue and reflection cracking. The Texas Overlay Tester was designed to simulate the expansion and contraction movements that occur in the vicinity of joints or cracks and which result in reflection cracking in overlays. With the Cox/Cooper Texas Overlay Tester it is possible to characterize both the crack initiation and crack propagation properties of asphalt mixtures. Cox/Cooper have developed the Texas Overlay Tester, which is a dedicated, state-of-the-art piece of equipment for carrying out this test.

Automatically calculates critical fracture energy and crack resistance index according to Tex-248-F.

Features:

- Dedicated no compromise Texas Overlay machine
- Integral surface-mounted, touch-screen control
- Intelligently designed specimen gluing and "zero stress" carrying frame
- Fitted with high performance hydraulic actuator and powerpack
- Ergonomically designed for easy operation

Overlay Tester, 240V 50/60Hz

HA-5600.4F

Ship wt. 1102 lbs. (500kg)

Texas Overlay Tester includes:

HA-5600.4F Includes	Model
Pair of Platens with pins for Texas Overlay	HA-5600.7
"Zero Stress" carrying frame to align the two base plates and fix the specimen prior to testing with specimen alignment	HA-5600.8
Cutting Template	HA-5600.10
Two-part epoxy with minimum 24 hour tensile strength of 4.1MPa and 24hr shear strength of 13.8MPa in accordance with Tex-614-J (Devcon™ two-ton 30-Minute Plastic Steel Epoxy Cement)	HA-5600.11
2mm x 4.2mm spacer bar for plate separation and alignment	HA-5600.5
5 lb (2.25 kg) weight (in the shape of the specimen to ensure load is spread evenly and does not overhang the edges of the specimen)	HA-5600.9
0.25" width adhesive tape	HA-5600.12
Permanent marker	HA-5600.13
Glue removing agent	HA-5600.14
Gluing Jig	HA-5600.15

Accessories	Model
Texas Overlay Prep Table/ Gluing Jig	HA-5600.8
10 lb (4.5 kg) weight (in the shape of the specimen to ensure load is spread evenly and does not overhang the edges of the specimen)	HA-5600.5
Calibration Kit	HA-5600.6
Semi-circular Bending	HA-5600.2

ACCESSORIES

Accessories are not included and should be ordered separately.



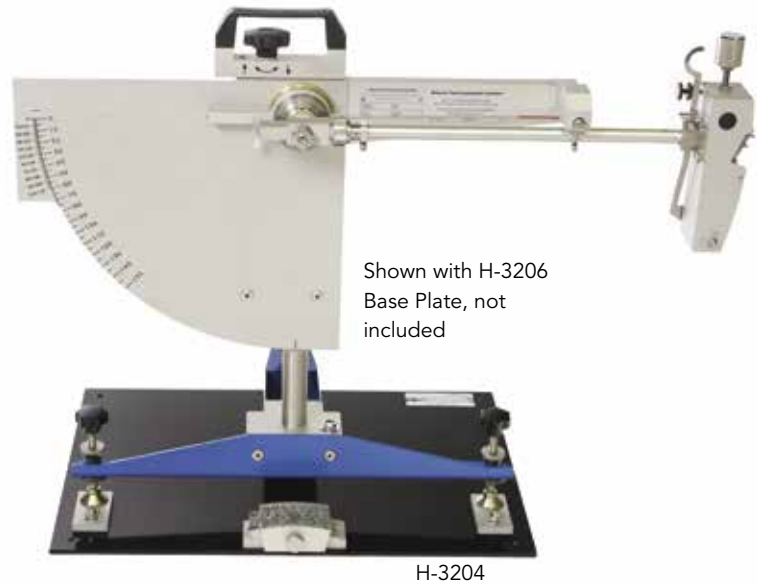

Shown with H-3206 Base Plate, not included

Accelerated Polishing Machine

BS 812 Pt 114 EN 1097-8

The accelerated polishing machine polishes samples of aggregates, simulating actual road conditions, and is used in conjunction with the portable skid resistance tester to determine the polished stone value for aggregates used in road surfaces, and gives a measure of the resistance to skidding. Fourteen specimens are clamped around the "road wheel" of the polishing machine, and subjected to two stages of polishing by a loaded rubber tire. First by corn emery, and secondly by emery flour. Use of the accelerated polishing machine and the skid resistance tester in road construction has had a major influence in reduction of accidents.

The H-3205 features:

- Heavy welded steel mainframe, standing in adjustable pads
- Digital display preset timer and revolution counter.
- Specimens are easily affixed and removed from testing wheel
- Water gravity fed from high level tank through calibrated flowmeter.
- Used abrasive and water collected in removable tray.
- Loaded tire raised and lowered to the running surface by mechanical lifting device.

- Easily removed covers and guards protect operator during testing and safety switch ensures removable safety covers are in place.
- Comes with four molds and two mold plates.

Dimensions: 32"x 32"x 48" (82 x 82 x 123cm)

Acc. Polishing Machine, 120/220V 50/60Hz H-3205.3F
Ship wt. 463lbs. (210kg)

Portable Skid Resistance Tester

ASTM E303; BS EN 1097-8; BS 812 Pt 114

Measures friction (skid resistance) on flat, cambered, or gradient road surfaces. Originally developed by the Transport and Road Research Laboratory of Great Britain.

- Compact, easily transported and used in the field
- Can be used in remote locations, independent of any vehicle
- Enclosed bearings & working parts for protection against wear and contamination
- Heavy-duty frame construction
- Adjustable feet on base

A pendulum arm, having a spring-loaded rubber slider on the pendulum foot. Device is placed on the portion of the road surface to be tested. It is then leveled, and the height of the center of suspension of the pendulum is adjusted to a fixed value which is read on a special gauge.

The pendulum is then released from its horizontal position, to swing down freely until the rubber slider contacts the test surface. As the slider travels across the surface for a fixed distance, the pendulum is slowed and a frictionally-constrained pointer

affixed to the pendulum arm measures the highest point in the pendulum arc. The position of the pointer is then read on a measuring arc graduated from 0 to 150. Pointer readings indicate the resistance to skidding of the test surface. Dimensions (include carrying case): 31" x 25.5" x 9" (787 x 648 x 229mm).

Portable Skid Resistance Tester

H-3204

Ship wt. 88lbs. (39.9kg)

H-3204 Accessories	Model
Rubber slider, 1.25", for lab use	H-3207
Rubber slider, 3", for field use	H-3208
Laboratory base plate	H-3206





HM-9110
HM-9111

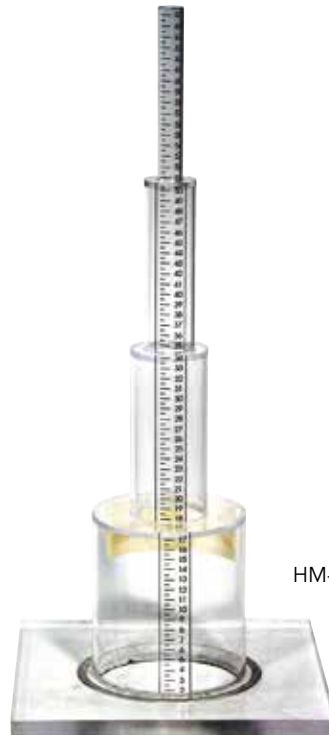

HM-9113.1

Asphalt Permeameter

These asphalt permeameters are compact, self-contained, easy-to-use units, which can be used in the lab or in the field. They are used to test the permeability of a compacted asphalt paving mixture by using the falling head method to determine hydraulic conductivity of saturated 4" or 6" samples. To use, place the specimen inside the metal cylinder, where it is held in place by a latex membrane. The unit is then pressurized by the built in hand pump. The expanding membrane pushes against the outer edge of the sample, filling in voids and preventing flow down the side of the core. The sample is then saturated from the bottom, and 500cc of water is allowed to flow through the sample while being timed. Both permeameters include a 500cc manometer with 15 ft of 0.25" OD water line, built-in hand pump and a pressure gauge.

Asphalt Permeameter, 4" HM-9110
 Asphalt Permeameter, 6" HM-9111
Ship wt. 20lbs. (9kg)

Asphalt Permeater Parts	Model
4" Membranes	HM-9110.2
6" Membranes	HM-9111.2
4" O-rings	HM-9110.1
6" O-rings	HM-9111.1

NCAT Field Permeameter Kit

The NCAT field permeameter kit is a falling-head permeameter using Darcy's law to determine rate of water flow through asphalt pavement. This design was selected by the National Center for Asphalt Technology (NCAT) for its close correlation with laboratory test results. Testing and subsequent calculations can usually be completed in 10-15 minutes by one technician.

The HM-9113.1 permeameter is a supplied in two sections and constructed of rugged plastic. In use, sealing material is placed on the base plate and the unit seated against the pavement using gentle foot pressure and included base weights. After filling with water, outflow is observed using the clearly marked graduations. The smallest, uppermost tier allows rapid determinations in low-porosity pavements. The larger diameter tiers are used to accurately read flow on more porous pavements. The alternate top section can be used to replace the two top tiers with one larger diameter tier. This allows for extended test times on moderately permeable mats or for rapid filling when testing highly permeable mixes. The NCAT field permeameter kit provides the user with a complete operation package for using the NCAT field permeameter. It includes the 4-tiered HM-9113.1 permeameter; an alternate graduated top section; a filling tube; moldable sealant for sealing the permeameter to its base; a whisk broom for test site preparation and (4) 5lb (2.3kg) base weights to help seal the permeameter to the test surface.

NCAT Field Permeameter Kit HM-9113
Ship wt. 49lbs. (22.2kg)

NCAT Field Permeameter (Permeameter Only)

The NCAT field permeameter is for those who don't wish to buy the complete kit or who need to replace an existing one. This field permeameter is the same permeameter used in the HM-9113 kit. The HM-9113.1 permeameter is supplied in two sections and constructed of rugged plastic. In use, sealing material is placed on the base plate and the unit seated against the pavement using gentle foot pressure and included base weights. After filling with water, outflow is observed using the clearly marked graduations. The smallest, uppermost tier allows rapid determinations in low-porosity pavements. The larger diameter tiers are used to accurately read flow on more porous pavements.

NCAT Field Permeameter HM-9113.1
Ship wt. 14lbs. (6.3kg)





Shown with H-3221HA horizontal digital gauge and cover removed.

H-3220A



H-3221HA



H-3222



H-2790

Benkelman Beam

AASHTO T256

The Benkelman beam measures the deflection of a flexible pavement under moving wheel loads. Extremely accurate and easy to use. Direct-reading dial indicator eliminates need for conversion tables or field calculations. This pavement analysis tool provides the following features:

- Precision accuracy
- Easy to use on test site
- Lightweight, quick set-up
- Easy to transport, easy to store
- No need for conversions or field calculations, gauges are direct read.

Order dial gauge separately.

Dial indicator vibrator system assures accurate pavement measurements. Telescoping design adds convenience, reduces weight, and saves storage space. Lightweight aluminum construction.

Specifications	
Main body	Aluminum with black finish 55" (1397mm) long
Probe beam	8 ft. (2.4m) aluminum beam telescopes into body
Probe fulcrum	Provides lever ratio of 2:1, ball pivot bearing
Vibrator system	Assures measurement accuracy. Top-mounted operating switch for easy use. Requires 4 "D" size batteries
Dial indicators	Ordered separately. Adjusted for direct read
Leveling wheel	Elevation adjustment
Overall length	With beam fully extended 12 ft. (3.7m).

Benkelman Beam H-3220A Ship wt. 62lbs. (28kg)

Digital Indicator, Horizontal

Horizontal-reading, digital indicator for use with the H-3220A Benkelman beam. No more laying on the ground to read a dial indicator. We've also redesigned the gauge cover on the beam, so that you can now store the new horizontal digital indicator mounted to the Benkelman beam, speeding set up and keeping the gauge and beam together, eliminating the chance of forgetting the gauge. Horizontal digital Indicator: 1.0" range x 0.001" resolution. Designed for use with the Humboldt H-3220A Benkelman beam. The indicator's 2:1 logic ratio allows it to provide direct readings of benkelman beam results without manual computations. Can be read in inches or metric units

Digital Indicator, Horizontal H-3221HA Ship wt. 2lbs. (0.9kg)

Dial Indicator, Vertical, 1" x 0.002"

Vertical-reading, dial indicator for use with the H-3220A Benkelman beam. 1" range x 0.002" divisions

Dial Indicator, Vertical, 1" x 0.002" H-3222 Ship wt. 1lbs. (0.5kg)

Dial Indicator, Vertical, 25 x 0.02mm

Vertical-reading, dial indicator for use with the H-3220A Benkelman beam. 25mm range x 0.02mm divisions

Dial Indicator, Vertical, 25 x 0.02mm H-3222M Ship wt. 3lbs. (1.4kg)

Bell/Buzzer Indicator

Sounds simultaneously with visual indicator, 9V DC battery

Bell/Buzzer Indicator H-2790B Ship wt. 3lbs. (1.4kg)

High-Low Detector (Rolling Straight Edge)

Used to measure planeness of pavement surfaces, such as highways, airport runways, bridge decks, etc. Requires only one operator to detect, register, and dye mark high and low areas that need to be ground down or filled.

Operator has full view of variations which are magnified 16 times, on a vertical scale graduated in 0.125" (1mm) increments, so that magnified readings range up to 0.25" (6.4mm), high or low. The 16 ft. long model incorporates aluminum reinforcing riveted along both sides of the frame for added support and rigidity. Frame is constructed of rectangular aluminum and wheels are provided, one front and one rear with precision ball bearings and neoprene tires for support. Scraper blades keep wheels clean to maximize accuracy. Includes wheel stands for stabilizing during calibration, transport and storage. There is provision for checking wheel alignment. A steering handle is provided for easy positioning and movement, and provides a button for dye discharge. Marking dye is used to mark high and low areas on pavement. Dye can mount is designed for 12 oz. (340g) aerosol cans.

Shipping weight	H-2790: 166 lbs. (75.2kg)
	H-2791: 160 lbs. (100kg)
	H-2792: 414 lbs. (72.5kg)

High-Low Detector, 10 ft. (3m) Span	H-2790
High-Low Detector, 12 ft. (3.7m) Span	H-2791
High-Low Detector, 16 ft. (4.9m) Span	H-2792

see table above

Bell/Buzzer Indicator

Provides audible alert, 9V DC battery

Bell/Buzzer Indicator H-2790B Ship wt. 3lbs. (1.4kg)

Dye, Aerosol Can, 12-pack
12 pack of 16oz. (454g) spray cans

Dye, Aerosol Can, 12-pack H-2790D Ship wt. 12lbs. (5.4kg)

Aerosol Cans cannot be shipped internationally.





HR-2801.6F



HR-2802



HR-2500



HR-2508

Hand-Held Core Drill

The HR-2801 Hand-Held Core Drill can be used for hand-held drilling up to 4". Perfect tool for sample drilling and drilling smaller holes for ventilation, plumbing pipes, joints, electrical sockets and telecome cable openings. It is equipped with a LED indicator that shows when the drill is in a vertical or horizontal position and can also be calibrated to help guide the operator while angle drilling. The positioning system makes it possible for the operator to focus on drilling while controlling the position of the machine via the LED indicators. It is equipped with Softstart™, which slowly increases motor RPMs when starting, which reduces wear on the motor and brushes. The drill comes with a vac port as standard for use in dry applications, such as drilling bricks, blocks or other building materials. Can be used for wet applications when drilling reinforced concrete. Includes case.

Held-Core Drill, 120/220V 60Hz **HR-2801.6F**
 Ship wt. 15.4lbs. (6.9kg)

HR-2801 Hand-Held Drill	
Motor	115/230V 60Hz
Bit capacity, handheld	4"
Bit capacity, with stand	6"
Speeds (no load)	900, 2150 4500
Speeds (full load)	500, 1400 2900
Auger capacity	NA

Small, 1-Speed Drill Stand

Perfect stand for drilling in walls and floors with the HR-2801 Hand-held Drill. Can also be used to angle drill and stitch drill. Maximum drill diameter is 10" (254mm) and max travel is 27" (685mm). Max tilt angle is 60°.

Small, 1-Speed Drill Stand **HR-2802**
 Ship wt. 16lbs. (5.9kg)

Core Drill, Electric

This core drill provides a flexible, multi-purpose vacuum/anchor bolt drilling system. It can be used for almost all applications involving floor, wall and ceiling placements, as well as hard-to-reach places. Includes a two-speed (350-900 RPM), 3.5 HP 20 amp heavy-duty motor, waterproof switch box, built-in water swivel, continuous duty oil-less vacuum pump, filter, hose, quick connections and has a 12-inch bit diameter capacity. The drill's 6" (254mm) wide base is a vacuum pad anchor with more than 1000 pounds of vacuum force that solidly grips the drilling surface within seconds making it the ideal drill stand for floors, walls, ceilings, as well as, pavement. Requires water supply, if none is available order HR-2516 portable water pressure tank separately.

Features include:

- 3.5 HP Milwaukee electric drill motor with 2-speed gear box
- Water swivel
- Drill stand with combination vacuum pad/anchor bolt base
- Large (6") rubber wheels

HR-2500	
Horse power	3.5
Motor: volts/amps	115/20
Cycle	50/60
Bit capacity	12"
Auger capacity	NA
Column dimensions	2.5" x 35"
Carriage travel	22"

Core Drill, Electric 120V 60Hz **HR-2500**
 Core Drill, Electric 230V 50/60Hz **HR-2500.4F**
 Ship wt. 130lbs. (60kg)

Core Drill, Hand-held, Gas-Powered

Hand-held, portable, ultra lightweight core drilling machine, gasoline powered; just add gasoline and water and start drilling. Perfect for road, bridge and fencing contractors. For fast, economic drilling—either vertical or horizontal—of concrete/asphalt and/or auger drilling into soil. One-person drilling, easy-to-handle, 22 lbs. overall weight. Quick set-up, easy-to-use, reliable. Honda 31cc, 4-cycle gasoline engine, high performance water swivel, bit locator. Accepts up to 6" diameter.

Features include:

- Designed for concrete/asphalt surfaces
- Minimize drilling time with gasoline power
- Easy-to-use and quick to set up
- One-person, hand-held, core drill machine
- 31cc, gasoline powered engine - 4 cycle
- 7" bit diameter capacity
- Vertical or horizontal drilling
- Heavy-duty, quad precision ball bearing gear box

HR-2508	
Motor	31cc, 4-cycle
Bit capacity	6"
Auger capacity	NA

Core Drill, Hand-held, Gas-Powered **HR-2508**
 Ship wt. 40lbs. (18kg)





HR-2503E



HR-2701



HR-2600

Core Drill, Mobile Stand, Gas-Powered

This core drill reduces job costs through the faster drilling speeds gained from the use of a gas-powered motor. This drill can be wheeled into place easily when mounted on its heavy-duty, sturdy platform or can also be mounted to a trailer, pickup or van.

Features include:

- 17 HP gas-powered, electric-start drill head with electric start, with 8" or 16" bit capacity
- Accurate and easy drill positioning and platform movement with its 4" Delrin wheels
- Dead-weight base no anchor bolts required
- Drill stand

Standard package includes:

- Drill stand
- 17 HP gasoline-powered, electric-start engine
- Variable RPM (300-1500 bit RPM)
- Water swivel

HR-2503E and HR-2504	
Horse power	17
Cycle	4
HR-2503E bit capacity	8"
HR-2504 bit capacity	16"
Auger capacity	NA

Core Drill, Mobile Gas-Powered — 8" HR-2503E

Core Drill, Mobile Gas-Powered — 16" HR-2504
Ship wt. 413lbs. (187kg)

Core Drill, Hitch-Mounted

This hitch-mounted system provides a mobile system, which provides fast set-up and drilling while ensuring consistent quality. Setup minimizes time required to do jobs reducing job costs.

Features include:

- 15 HP gas-powered, electric-start drill head with electric start, with 16" bit capacity
- Accurate drilling with easy positioning and alignment of drill head
- Positioning arm swings 180° in semi-circle
- Multi-jointed arm allows drilling anyway within the arc of trailer-hitch mount
- Stand-alone, gasoline-powered system— no additional power supplies needed
- Easy, one-person mounting or removal using machine's own drill caddy

Standard package includes:

- Drill Head with up to 16" bit capacity
- Flexible position receiver mount bracket
- Drill caddy
- Variable RPM (300-1500 bit RPM)
- Water swivel
- Drive shaft stabilizer system

HR-2700 and HR-2701	
Horse power	15
Cycle	4
HR-2700 bit capacity	16"
HR-2701 bit capacity	16"
HR-2700 auger capacity	NA
HR-2701 auger capacity	8"

Core Drill, Hitch-Mount 16" Capacity HR-2700

Core Drill, Hitch-Mount, Auger Capability HR-2701
Ship wt. 604lbs. (274kg)

Core Drill, Trailer-Mounted

This complete stand-alone core drill rig offers field independence, versatility, dependability, and easy single-person operation. Provides mobile yet very stable drilling platform, which extends bit life. Provides exceptional solution for remote locations.

Features include:

- 17 HP gasoline-powered drill head with electric start, with 16" bit capacity and a 24" travel;
- Variable drill head positioning system, which allows drill head movement of approx. 43" side-to-side and 12" fore and aft for accurate hole placement;
- Hydraulic-assisted machine lift for single-handed removal and replacement of drill;
- Lockable, weather-resistant toolbox;
- 200-gal. water tank and 12 VDC water pump
- 5' x 8' steel-construction trailer, equipped with electric brakes and pre-wired for brake and tail lights.

HR-2600 and HR-2601	
Horse power	17
Cycle	4
HR-2600 bit capacity	16"
HR-2601 bit capacity	16"
HR-2600 auger capacity	NA
HR-2601 auger capacity	8"
Carriage travel	24"

Core Drill, Trailer-Mount 16" Capacity HR-2600

Core Drill, Trailer-Mount, Auger Capability HR-2601
Ship wt. 2000lbs. (907kg)





Z-Edge for concrete



Core Drill Accessories

Description	Model
Extension rod, 9" (229mm); for drilling holes deeper than 12" (305mm)	HR-2510
Strap wrench, 18" (457mm) allows bit removal from drill spindle without damage to bit barrel	HR-2514
Angle drilling attachment for HR-2500. Tilts column to allow drilling from 90° to 45° angle from surface	HR-2515
Portable water pressure tank. Hand-operated. 4 gallon (15 liter), delivers water under pressure when water supply is not available.	HR-2516
Water trapping assembly, confines wastewater on surface and electric pump moves water into container	HR-2511
Diamond bit edge dresser	HR-2512
Replacement wheel for diamond bit edge dresser (HR-2512)	HR-2513

ExitPoint Through-hole Drill Guide

Accurately detect exit points before drilling and coring with the ExitPoint through-hole drill guide. The HR- is the easiest and fastest way to locate a precise spot, without measuring, before you start your project. Scans through most types of non-magnetic building materials, such as wood, drywall, gypsum panels, bricks, and poured concrete up, to 11.81 in. (300 mm) thick.

This simple, yet effective, tool saves time and money by reducing guesswork, rework, unnecessary holes, and costly broken drill bits. Ideal for cable and wire installations, concrete scanning, and anytime through-hole drilling is required.

ExitPoint Through-hole Drill Guide **HR-2599**
 Ship wt. 1.4lbs. (0.64kg)

Diamond Drill Bits

These professional-quality, diamond, drill bits are designed for use in drilling asphalt and concrete. They have a total segment height of .320" (8.128mm), a diamond depth of .250" (6.350mm) and a segment base of .070" (1.778mm). The standard bit length is 13" (330.200mm) and the integral thread adapter is 1.25" – 7 thread.

Concrete drill bits are for critically hard concrete with heavy, steel reinforcement. Asphalt drill bits are for asphalt and concrete with soft, abrasive aggregate.

Size		Asphalt	Concrete
In.	mm		
1	25	HR-2550.1	HR-2530.1
1.125	29	HR-2550.1125	HR-2530.1125
1.25	32	HR-2550.125	HR-2530.125
1.5	38	HR-2550.15	HR-2530.15
1.75	44	HR-2550.175	HR-2530.175
1.875	63	HR-2550.1875	HR-2530.1875
2	51	HR-2550.2	HR-2530.2
2.25	57	HR-2550.225	HR-2530.225
2.5	63	HR-2550.25	HR-2530.25
2.75	70	HR-2550.275	HR-2530.275
3	76	HR-2550.3	HR-2530.3
3.5	89	HR-2550.35	HR-2530.35
4	100	HR-2550.4	HR-2530.4
4.25	108	HR-2550.425	HR-2530.425
4.5	114	HR-2550.45	HR-2530.45
5	127	HR-2550.5	HR-2530.5
5.5	140	HR-2550.55	HR-2530.55
6	152	HR-2550.6	HR-2530.6
6.25	159	HR-2550.625	HR-2530.625
7	178	HR-2550.7	HR-2530.7
8	203	HR-2550.8	HR-2530.8
9	230	HR-2550.9	HR-2530.9
10	254	HR-2550.10	HR-2530.10
11	280	HR-2550.11	HR-2530.11
12	305	HR-2550.12	HR-2530.12
13	330	HR-2550.13	HR-2530.13
14	350	HR-2550.14	HR-2530.14

Diamond Drill Bits, High-Performance, Small

These professional-quality, diamond drill bits are designed for drilling cured concrete with medium to soft aggregate with or without steel reinforcement. They have a total segment height of .400" (10.160mm) (.300" (7.620mm) diamond depth and .100 (2.54mm) segment base. The standard bit length is 13" (330.200mm) and the integral thread adapter is 1.25" – 7 thread.

Size		Medium***
Inches	mm	
1/2	13	HR-2570.5
5/8	17	HR-2570.625
3/4	19	HR-2570.75
7/8	22	HR-2570.875
1	28	HR-2570.1

CoreSnap Removal Tool

The CoreSnap allows you to remove a drilled sample from a roadbed at or below the tackline without prying or drilling completely through the old roadbed. The CoreSnap is placed down over a normally cut core and tighten the binding bolt with a 0.25" drive socket/ratchet. A quick lateral motion of the handle breaks the core sample away from the older mat beneath, allowing the core to be removed easily.

CoreSnap Removal Tool, 4" **HR-2554**
 CoreSnap Removal Tool, 6" **HR-2556**

Ship wt. 10.4lbs. (4.7kg)



NOTES

Be advised that core drill bits have .125" walls and produce a core 0.25" smaller than the OD of the drill bit.





HA-5100.3F

Servo-Pneumatic Universal Testing Machine (15.5kN)

ASTM D4123, D7369, D7313, D8044; AASHTO TP31, TP62, TP79, TP105, TP124, T307, T322, T342; NCHRP 9-19; EN 12697-24 Annex E, EN12697-25 Method A and B, EN 12697-26 Annex C and E

This machine is a development of the NAT which was developed by Keith Cooper and Professor Steven Brown at the University of Nottingham. The use of a high precision servo-pneumatic valve in conjunction with a low-friction actuator and sophisticated data acquisition and control, results in a performance that is equal to many servo-hydraulic systems.

Accurate, digitally generated waveforms are applied by the actuator producing repeatable stress variations in test specimens that are simulative of those in a road pavement due to moving traffic. The actuator is double-acting allowing both compressive and tensile forces to be applied. A tri-axial cell system is available for the measurement of the resilient modulus of unbound materials.

Features:

- Low cost dynamic loading universal test system ideally suited to testing asphalt and unbound granular materials
- High performance ceramic spool servo-valve
- Double acting low friction actuator with integral stroke transducer
- High quality stainless steel frame
- Accessories available to perform a range of standard and non standard test methods

Control System and Software

This machine can be controlled using our Standard Acquisition and Control System along with Universal Software™. Universal Software is user friendly, intuitive and reliable Windows® software developed using LabVIEW™. Universal test software

Specifications	
Maximum Load	3500lb (15.5kN) dependent on air pressure
Load Transducer	±4496lb (20kN)
Actuator Stroke	1.2" (30mm)
Frequency	0 to 30 Hz
Electrical Supply	110/220V 50/60 Hz, 1 Ph
Compressed Air	7-10 bar (100-145psi) @ 21cfm (600 lpm)
Dimensions	31" x 40" x 76" (780 x 1000 x 1920mm)
Working Space Required (WxDxH)	32.5" x 65" x 83" (825 x 1650 x 2100mm)
Desktop PC	Included



INSTALLATION

Installation Verification and on-site Training are available for the Gyratory, please inquire.

for the development of test methods using static, sinusoidal, haversine, square, triangular with user selected frequencies and data collection rates. Stored test data can be imported into a spreadsheet package to be analyzed by the user. Utilities are included for transducer check, diagnostic routines and calibration.

cDAC™ Advanced Data Acquisition

Alternatively, our next generation digital data acquisition and control unit cDAC™ Advanced Data Acquisition System brought together in alliance with our flagship software DIMENSION™ gives you the power to perform the most demanding of tests with your materials testing equipment. cDAC™, our next generation, class-leading digital controller is unparalleled in its field and suitable for advanced testing required for research.

For more details on Control System & Software, please refer to page 298.

15.5kN Universal servo-pneumatic testing machine with standard control box., includes desktop PC with Universal software.

15.5kN Machine, Standard, 120/220V 50/60Hz HA-5100.3F
Ship wt. 79lbs. (36kg)

15.5kN Universal servo-pneumatic testing machine with cDAC control box, includes desk PC with Dimensions software.

15.5kN Machine, cDAC, 120/220V 50/60Hz HA-5101.3F
Ship wt. 79lbs. (36kg)

Accessories	Model
Temperature-controlled Cabinet	HA-5100.1

Specifications		
Model	UTM25	UTM100
Maximum force	5620lbf (25kN)	22481lbf (100kN)
Load transducer	5620lbf (25kN)	22481lbf (100kN)
Actuator stroke	2" (50mm)	4" (100mm)
Frequency range	0 to 100Hz	0 to 100Hz
Electrical supply	220V 60 Hz, 3 Ph	220V 60 Hz, 3 Ph
Frame and cabinet dimensions (WxDxH)	39" x 51" x 94" (1000 x 1300 x 2400mm)	45" x 47" x 108" (1150 x 1200 x 2750mm)
Powerpack dimensions (WxDxH)	25" x 23" x 35" (630 x 580 x 890mm)	27.5" x 37" x 43.7" (700 x 940 x 1110mm)
Working space (WxDxH)	43" x 90.5" x 102" (1100 x 2300 x 2600mm)	118" x 157" x 118" (3000 x 4000 x 3000mm)
Desktop PC	Included	Included



Servo-Hydraulic Universal Testing Machine (25kN and 100kN)

ASTM D4123, D7369, D7313, D8044; AASHTO TP31, TP62, TP79, TP 105, TP124, T307, T322, T342; NCHRP 9-19; EN 12697-24 Annex E, EN12697-25 Method A and B, EN 12697-26 Annex C and E

The Servo-Hydraulic Universal Testing Machines are well-designed, versatile machine specifically developed for the testing of materials used in pavement construction.

25kN Machine Features

- Designed to perform a range of tests on asphaltic paving materials, sub-grade soils and granular sub-base materials
- Double acting fatigue rated hydraulic actuator with integral stroke transducer
- Star servo valve with "Sapphire Technology"
- Motorized adjustable lower crosshead with automatic hydraulic frame clamping
- Integral programmable temperature controlled cabinet
- Accessories available to perform a range of standard and non-standard test methods

100kN Machine Features

- Double rod, equal area, fatigue rated actuator
- Direct coupled Star Hydraulics servo valve with Sapphire Technology
- Direct coupled hydraulic safety block
- Axially mounted LVDT integral to the actuator
- Optional TCC is fully removable to allow increased daylight for testing large temperature-independent specimens.

Control System and Software

This machine can be controlled using our Standard Acquisition and Control System along with Universal Software™. Universal Software is user friendly, intuitive and reliable Windows® software developed using LabVIEW™. Universal test software for the development of test methods using static, sinusoidal, haversine, square, triangular with user selected frequencies and data collection rates. Stored test data can be imported into a spreadsheet package to be analyzed by the user. Utilities are included for transducer check, diagnostic routines and calibration.

cDAC™ Advanced Data Acquisition

Alternatively, our next generation digital data acquisition and control unit cDAC™ Advanced Data Acquisition System brought together in alliance with our flagship software DIMENSION™ gives you the power to perform the most demanding of tests with your materials testing equipment. cDAC™, our next generation, class-leading digital controller is unparalleled in its field and suitable for advanced testing required for research.

For more details on Control System & Software, please refer to page 298.

25kN Universal servo-hydraulic testing machine with integral temperature controlled cabinet, standard control box. Includes desk PC with Universal software.

25kN Machine, Standard, 220V 60Hz HA-5125.2F
Ship wt. 79lbs. (36kg)

25kN Universal servo-hydraulic testing machine with integral temperature controlled cabinet, cDAC control box. Includes desk PC with Dimensions software.

25kN Machine, cDAC, 220V 60Hz HA-5126.2F
Ship wt. 79lbs. (36kg)

100kN Universal servo-hydraulic testing machine, standard control box. Includes desk PC with Universal software. Temperature controlled cabinet available as an optional extra.

100kN Machine, Standard, 220V 60Hz HA-5135.2F
Ship wt. 79lbs. (36kg)

100kN Universal servo-hydraulic testing machine, cDAC control box. Includes desk PC with Dimensions software. Temperature controlled cabinet available as an optional extra.

100kN Machine, cDAC, 220V 60Hz HA-5136.2F
Ship wt. 79lbs. (36kg)



INSTALLATION

Installation Verification and on-site Training are available for the Gyrotory, please inquire.



Accessory Fixtures for Universal Testing Machines

Standard	Accessory Description	Model	UTM-15.5kN	UTM-25kN	UTM-100kN
NCHRP 9-19 AASHTO TP62	Test system to perform dynamic modulus according to AASHTO TP62, SPT flow number (NCHRP 9-19), SPT flow time (NCHRP 9-19)	HA-5123.1	✓	✓	✓
AASHTO T307	Triaxial system to perform AASHTO T307 for 200x100mm \varnothing specimens of unbound materials	HA-5123.2	✓	✓	✓
	Triaxial system to perform AASHTO T307 for 200x100mm \varnothing and 150x300mm \varnothing specimens of unbound materials. To use with CRT-UTM-NU pillar extensions are required.*	HA-5123.3	✓	✓	✓
	*Larger Pillars for UTM-NU (for T307+)	HA-5100.2	✓	✗	✗
	Additional parts to upgrade from T307 to T307+	HA-5123.5	✓	✓	✓
AASHTO T322	Indirect Tensile Creep measurement system according to AASHTO T322	HA-5123.6	✓	✓	✓
AASHTO TP 124 AASHTO TP 105 ASTM D8044	Semi circular bending system to perform ASTM D8044, AASHTO TP 124 and TP 105 test	HA-5123.7	✓	✓	✓
ASTM D7369	Resilient modulus test system to perform ASTM D7369	HA-5123.8	✓	✓	✓
EN 12697-26 (Annex E)	Direct Compression & Tension Measurement System to perform test according to EN 12697-26 Annex E for CRT-UTM-NU	HA-5100.3	✓	✗	✗
	Direct Compression & Tension Measurement System to perform test according to EN 12697-26 Annex E for CRT-UTM-HYD	HA-5123.10	✗	✓	✓
EN 12697-26 (Annex C) EN 12697-24 (Annex E)	Indirect tensile fatigue measurement system to perform EN 12697-24 (Annex E) for 100mm \varnothing specimens. To be used with CRT-ITSM-SET.	HA-5123.11	✓	✓	✓
	Indirect tensile fatigue measurement system to perform EN 12697-24 (Annex E) with 100 & 150mm \varnothing specimens. To be used with CRT-ITSM-SET.	HA-5123.12	✓	✓	✓
	Indirect tensile stiffness modulus and fatigue measurement system to perform EN 12697-26 (Annex C) \varnothing 100 & 150mm and EN 12697-24 (Annex E) \varnothing 100mm specimens.	HA-5123.13	✓	✓	✓
	Indirect tensile stiffness modulus measurement system to perform EN 12697-26 (Annex C) \varnothing 100&150mm specimens.	HA-5123.14	✓	✓	✓
	Add-on for CRT-FAT-SET for 150mm \varnothing specimens. To be used with CRT-ITSM-SET and CRT-FAT-SET.	HA-5123.15	✓	✓	✓
	EN12697-25 (Method A & B)	Dynamic and static creep measurement system to perform EN12697-25 (Method A)	HA-5123.16	✓	✓
Dynamic and static creep measurement system - confining stress to perform test according to EN 12697-25 Method B.		HA-5123.17	✓	✓	✓
IAN 73/06 – Design Guidance for Road Pavement Foundations	PUMA - Precision Unbound Materials Analyser for 150mm \varnothing specimens	HA-5123.18	✓	✓	✓
	PUMA - Precision Unbound Materials Analyser for 300mm \varnothing specimens	HA-5135.6	✗	✗	✓
	Temperature Controlled Cabinet	HA-5100.1	✓	✗	✓



HA-5105.3F

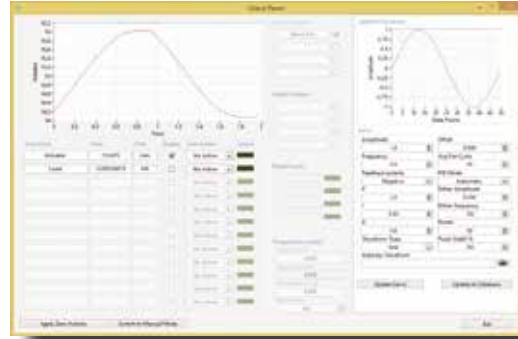

cDAC™ Controller and Data Acquisition

The cDAC digital data acquisition and control unit coupled with DIMENSION™ software, gives you the power to perform the most demanding of tests with our Universal, Dynamic Testing Machines. Both are designed with the ease-of-use and reliability required for standard testing and the flexibility and advanced capabilities required for research.

DIMENSION™ Software Features

- Profile builder gives ultimate flexibility to design and store custom testing routines
- Standard test library for quick and reliable testing to ASTM, AASHTO and CEN Standards
- Transducer database to store and manage your sensors
- Configurable waveform and summary data capture allows total control over the information gathered during a test
- Multi-lingual test screen shows a graphical view of all connected transducers and calculated values in real time
- Test data available in Excel™ compatible format for user analysis

cDAC™ Hardware Features

Provides a configurable design to meet your needs with up to 7 modules (max. 4 of each type) from the following per cDAC unit: Interface, Acquisition, Digital and Servo.

Interface Module

- 100Mbit/s Ethernet TCP/IP and UDP connection to PC provides for fast and robust communications
- RS232/422/485 serial port for connection to environmental chambers and other ancillary equipment
- USB port for direct data logging
- Atmel AT91SAM Smart ARM-based Micro-controller for high performance

Servo Module

- Dual 5kHz control loops per module
- 0.01 to 100Hz cycle frequency to meet all your testing needs.

- Digital on-the-y adjustment of all PID parameters
- Multichannel selectable feedback from any sensor (or sum of or difference between sensors) on any acquisition card
- Hardware function generator
- Bumpless transfer between control methods
- Texas instruments TMS320DSP digital signal processor
- 16-bit Analog Voltage ($\pm 10V$ and (0 to 10V) and Current ($\pm 40mA$, (0 to 20)mA, and (4 to 20mA) control output for servo valve or other control device

Digital Module

- 4 x 24V opto-isolated digital inputs with 100mA sink capacity (each can be configured as counters)
- 4 x 24V opto-isolated digital outputs to drive auxiliary hydraulic/pneumatic solenoid valves with 1.6A drive capacity per channel (each can be configured as a PWM source)
- NXP LPC2148 ARM7TDMI-S based high-performance 32-bit RISC micro-controller

Acquisition Module

- Any combination of up to 8 sensors per module (load cells, LVDTs, RTDs, strain gauge bridges, pressure transducers, and many, many more)
- TEDS (Transducer Electronic Datasheet) sensors for plug and play measurement
- Synchronous acquisition of all sensor measurements from all modules to eliminate data-skew
- Multiple segment 5th order polynomial linearization of sensors for supreme accuracy
- 24-bit resolution on all channels
- 5kHz acquisition rate per channel
- Anti-alias filters to prevent high-frequency interference
- Auto-ranging amplifiers with the following gain steps: 1/8, 1/4, 1/2, 1, 2, 4, 8, 16, 32, 64, 128
- (0 to 10)V, 24V, and (0 to 20)mA power supplies for sensors

cDAC Data Controller, 120/220V 50/60Hz HA-5105.3F
Shipping wt. 13lbs (6kg)

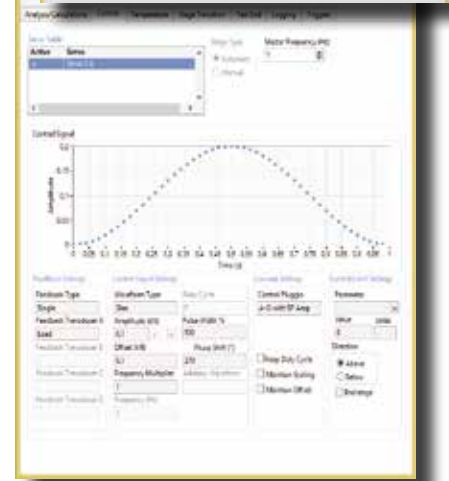



HA-5500.3F

Large Hydraulic, Four-Point Bending Beam Machine

ASTM D7460, AASHTO T321, EN 12697-24 Annex D, EN 12697-26 Annex B

The Large Hydraulic Four Point Bending Beam Machine uses advanced servo-hydraulic technology and a high-speed digital data acquisition and control system together with user-friendly software. During testing both graphical and tabular data are displayed on screen and test data is stored to disc in Microsoft Excel™ compatible format. The test frame is housed in a Temperature Controlled Cabinet with fan-assisted air circulation and a temperature range of -20 to 30°C. The unique constant torque clamping and three-transducer deflection measurement system of the

The Large Hydraulic Four Point Bending Beam Machine can be configured to accept different beam sizes. This means that the ratio between beam dimensions and maximum aggregate size of test specimens will satisfy the requirements of the relevant European specifications.

Features:

- Frequency range 0.1 to 60Hz
- High-quality, Servo-Hydraulic Four-Point Bending Machine
- Double-acting, fatigue-rated hydraulic actuator with integral stroke transducer

- Star servo valve with "Sapphire Technology"
- Can be used with simple one or research level three LVDT transducers
- Accepts various beam sizes: 380 to 660mm in length and 50 x 50mm and 100 x 100mm cross sections.
- Temperature Controlled Cabinet range -20 to 30°C
- Sinusoidal controlled strain or controlled stress fatigue test modes
- Constant torque motorized specimen clamping to eliminate errors due to localized beam indentation
- Self-contained loading system
- User friendly software for determination of fatigue resistance and stiffness modulus
- Capable of performing healing, modulus, fatigue multi-stage testing and camera triggering
- Supplied with traceable calibration certificate

Software:

- User friendly, intuitive and reliable Windows® software developed using LabVIEW™
- Specifically written to meet AASHTO and ASTM standards
- The user interface can be translated into the user's preferred language – please inquire

Specifications	
Force Transducer	2250lbf (10kN)
Specimen Transducer Range	±0.09" (3 x ±2.5mm)
Actuator Stroke	0.4" (10mm)
Frequency	0.1 to 60 Hz
Electrical Supply	415V 50Hz, 3 Ph
Compressed Air	7-10 bar (100-145psi) @ 3.5cfm (100lpm)
Test Frame Dimensions	41.5" x 43" x 83" (1050 x 1100 x 2100mm)
Working Space Required (WxDxH)	81" x 83" x 90.5" (2050 x 2100 x 2300mm)
Desktop PC	Included

- Stored test data can be analyzed and compared with other test data utilizing a spreadsheet package
- Utilities are included for curve fitting of acquired data; testing of system's inputs and outputs; phase correction and a transducer database for storing calibration factors

Large, 4-Point Machine, 415V 50Hz, 3PH HA-5500.7F.3

Ship wt. 1435 lbs. (650kg)

Accessories are not included and should be ordered separately.

Accessories	Model
Dummy PVC beam 2" x 2" x 15" (50 x 50 x 380 mm)	HA-5400.1
Dummy PVC beam 4" x 4" x 26" (100 x 100 x 660 mm)	HA-5400.2
Integrated compressed air option	HA-5400.3



INSTALLATION

Installation Verification and on-site Training are available for the Gytratory, please inquire.

Specifications	
Force Transducer	2248lbf (10kN)
Specimen Transducer Range	± 0.04" (1mm)
Actuator Stroke	0.4" (10mm)
Frequency	0.1 to 30 Hz
Electrical Supply	110/220V 50/60Hz, 1 Ph
Compressed Air	7-10 bar (100-145psi @ 21cfm (600 lpm)
Test Frame Dimensions	18" x 7.5" x 22.5" (440 x 190 x 570mm)
Data Acquisition Enclosure	15" x 11" x 5.5" (360 x 280 x 140mm)
Working Space Required (WxDxH)	32.5" x 65" x 83" (826 x 1650 x 2100mm)
Desktop PC	Included



HA-5400.3F

Stand-Alone, Four-Point Bending Beam Machine

ASTM D7460, AASHTO T321, EN 12697-24 Annex D, EN 12697-26 Annex B

The Stand Alone Four Point Bending Beam Machine uses advanced servo pneumatic technology and a high-speed digital data acquisition and control system together with user-friendly software. During testing both graphical and tabular data are displayed on screen and test data is stored to disc in Microsoft® Excel® compatible format. The clamps are at 118.5mm (4.67 inch) centers (the distance between the outer clamps is 335.6mm (14 inches) according to AASHTO specifications but the height and width of the beam can be varied).

Features:

- Frequency range 0.1 to 30Hz¹
- Low cost pneumatic stand alone four point bending machine
- Low-friction actuator and high performance ceramic spool servo-valve
- On-specimen measurement system removes errors due to frame flexure
- Designed for AASHTO beam sizes
- Sinusoidal controlled strain or controlled stress fatigue test modes

- Constant torque motorized specimen clamping to eliminate errors due to localized beam indentation
- Self-contained loading system
- User friendly software for determination of fatigue resistance and stiffness modulus
- Capable of performing healing, modulus, fatigue multi-stage testing and camera triggering

Software:

- User friendly, intuitive and reliable Windows® software developed using LabVIEW™
- Specifically written to meet AASHTO and ASTM standards
- The user interface can be translated into the user's preferred language – please inquire
- Stored test data can be analyzed and compared with other test data utilizing a spreadsheet package
- Utilities are included for curve fitting of acquired data; testing of system's inputs and outputs; phase correction and a transducer database for storing calibration factors

Small, 4-Point Machine, 110/220V 50/60Hz HA-5400.3F

Ship wt. 79 lbs. (36kg)

Accessories	Model
Dummy PVC beam 2" x 2" x 15" (50 x 50 x 380 mm)	HA-5400.1
Cabinet, temperature-controlled	HA-5400.3



INSTALLATION

Installation Verification and on-site Training are available for the Gyrotory, please inquire.