

Reading	Elapsed Time (hh:mm:ss)	Load (Lbf)	Disp. (in)	Pore Pressure (psi)	Corrected Load (Lbf)	Corrected Displacement (in)	Corrected Pore Pressure (psi)	$\Delta$ Pore Pressure (psi)	Corrected Area (in <sup>2</sup> )	Axial Strain (%)	Deviator Stress (psi)	Corrected Deviator Stress (psi)	$\sigma_1$ (psi)	$\sigma_3$ (psi)	$\sigma_1 - \sigma_3$	Abs
0	00:00:00	79.3	0.2460	80.0	0.0	0.0000	0.0	0.0	6.300	0.0	0.0	0.0	10.0	10.0	0.0	0.0
1	00:02:00	85.0	0.2640	81.7	5.7	0.0100	1.7	1.7	6.320	0.1	8.9	8.9	8.2	8.3	1.1	1.8
2	00:04:00	99.2	0.2820	82.8	19.9	0.0360	2.8	1.1	6.338	0.6	31	31	16.3	14.4	2.0	0.5
3	00:06:00	122.3	0.3000	84.0	43.0	0.0540	4.0	1.2	6.358	0.9	66	66	23	18	5.0	0.9
4	00:08:01	135.0	0.3170	84.8	55.7	0.0710	4.8	0.8	6.377	1.2	87	87	23	20	3.0	0.4
5	00:10:01	144.5	0.3350	84.9	65.2	0.0890	4.9	0.1	6.418	1.5	102	102	25.7	21	4.0	0.4
6	00:12:01	152.3	0.3530	85.2	70.5	0.1070	5.2	0.3	6.438	2.1	120	120	27.7	21	6.0	0.3
7	00:14:01	157.8	0.3710	85.2	83.8	0.1250	5.3	0.1	6.455	2.4	128	128	28.7	21	7.0	0.3
8	00:16:01	163.1	0.3880	85.3	88.1	0.1420	5.3	0.0	6.475	2.7	139	139	29.3	21	8.0	0.3
9	00:18:01	167.4	0.4060	85.3	93.7	0.1600	5.3	-0.1	6.494	3.0	144	144	29.9	21	9.0	0.3
10	00:20:01	169.5	0.4230	85.2	97.3	0.1770	5.1	-0.1	6.515	3.3	149	149	30.4	21	9.0	0.3
11	00:22:01	173.0	0.4410	85.1	100.2	0.1950	5.0	-0.1	6.534	3.6	153	153	31.0	21	10.0	0.3
12	00:24:02	176.6	0.4580	84.9	103.9	0.2120	4.9	-0.1	6.556	3.9	158	158	31.6	21	10.0	0.3
13	00:26:02	178.5	0.4770	84.8	106.8	0.2310										
14	00:28:02	183.2	0.4940	84.8	111.2											
15	00:30:02	186.1	0.5120	84.7	113.9											
16	00:32:02	190.5	0.5300	84.5	115.9											
17	00:34:02	193.2	0.5480	84.4												
18	00:36:02	195.2	0.5660	84.4												

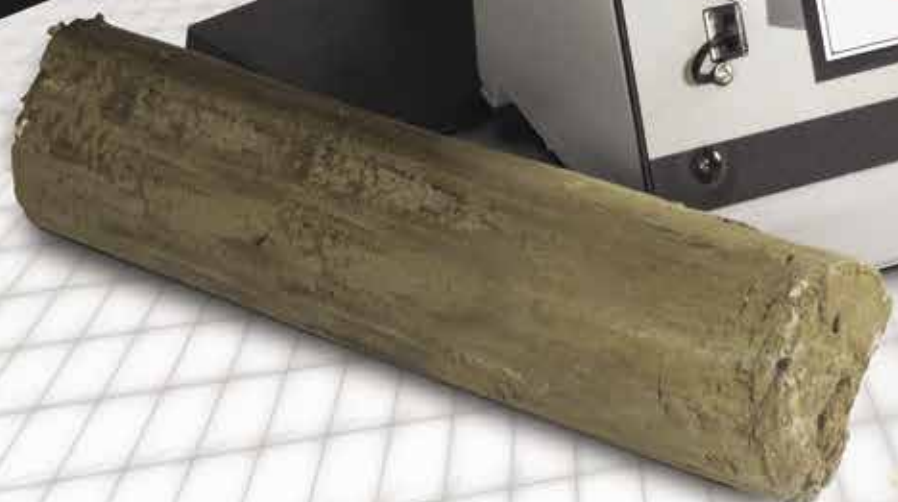

**5320**

DATA LOGGER  
 PREVIOUS TESTS CURRENT TESTS [44REDWIN]  
 LOAD\_I\_561485 -0.008 Lbf  
 PRESS\_I\_221764 1.927 psi  
 DISP\_I\_15394 0.014 in  
 VOLUME\_I\_15438 4.162 cm<sup>3</sup>  
 TEST CONTROL



# SOIL MECHANICS

Consolidation . . . . .	106-113	Triaxial Distribution Panels . . . . .	128-129
Consolidation Cell Components . . . . .	112-113	Triaxial Flex Panels . . . . .	129
Data Acquisition . . . . .	145-148	Triaxial Load Frames . . . . .	122-126
Direct Shear . . . . .	114-121	Triaxial Sample Prep . . . . .	142-144
Elite Series Equipment . . . . .	102-103	Triaxial Setup Accessories . . . . .	141
Erosion . . . . .	149	Triaxial Setup Components . . . . .	138-140
NEXT Software . . . . .	104-105	Triaxial Setups . . . . .	130-137
Triaxial Cells . . . . .	127		



# ELITE SERIES Soil Mechanics Equipment

Humboldt's Elite Series testing machines feature a 7", full-color touch-screen controller that provides you with full, graphical monitoring of all testing functions in stand-alone applications, while maintaining full PC control when desired. With Elite Series machines you can have full, finger-tip control and monitoring of all testing functions with the touch-screen controllers, found on our load frames, consolidation and direct-shear machines, as well as our other data acquisition loggers and controllers. Elite Series machines provide at-a-glance monitoring of testing functions, in a real-time graphical display, without the use of a PC, building upon Humboldt's dedication to modular, stand-alone, data-acquisition.

#### Stand-Alone Control

In stand-alone applications, you will be able to run tests and display results while viewing tabulation, basic x-y graphs and instrument readings in real-time during the test, using user-defined basic data acquisition. Test data is stored in the device and can be downloaded to a USB drive via the machine's USB port or the data can be transferred to a networked computer. The USB port can also be used to power a wireless access point, which can provide a wireless hook-up with the PC, if no LAN is available.

#### Computer Control

Humboldt's Next, Basic software is included with the all Elite Series machines. This software provides robust machine control, calibration, data acquisi-

tion and report generation for those using a computer to control various testing operations.

In addition, operators have the ability to view and control testing operations from a PC in the lab, in the next room or at a different location, while also providing report generating capabilities using Humboldt NEXT software test-specific modules, see page 105.

So, whether you are controlling a single load frame, controlling multiple machines or even a complete geotechnical lab, Humboldt's NEXT Basic software, in conjunction with Humboldt's Elite Series machines provide a complete solution for the acquisition, recording and presentation of testing data in data tabulation and graphic chart formats.





## Upgrade your existing Humboldt equipment to the Elite Series

You can upgrade your existing Humboldt testing equipment to our Elite Series machines. These upgrades require your existing machine to be sent to Humboldt for a complete refurbishment and upgrade to the new equipment. Upgrades include the new 7", full-color touch-screen controller, and a new enclosure. Refer to the chart on the right for available upgrades.

HM-3000.3F Upgrade to HM-5030.3F	HM-5030U
HM-2900.3F Upgrade to HM-5020.3F	HM-5020U
HM-2450.3F and HM-2315 Upgrade to HM-5240.3F	HM-5240U
HM-2325A.3F Upgrade to HM-5320.3F	HM-5320U
HM-2330D.3F Upgrade to HM-5330.3F	HM-5330U
HM-2470.3F Upgrade to HM-5470.3F	HM-5470U
HM-2560.3F Upgrade to HM-5560.3F	HM-5560U
HM-2750A.3F Upgrade to HM-5750A.3F	HM-5750AU
HM-2750D.3F Upgrade to HM-5750D.3F	HM-5750DU
HM-4469C Upgrade to HM-4470C	HM-4470U

# control and monitoring of all testing functions



## Choose: Stand-Alone or Computer Control

# NEXT SOFTWARE

## CONTROL, DATA ACQUISITION AND REPORTING



### Humboldt's, NEXT Basic software provides:

- Machine control, and data acquisition via networked computer
- Provides the ability to use NEXT software's, advanced test-specific modules
- Real-time graphical chart and numerical display of tests via computer display
- Effective sampling rate of 50 readings per second
- Stores unlimited tests with up to 3000 points per test.
- Up to 255 individual tests can be run simultaneously from a single PC
- Advanced, test-specific modules are available, which provide all the calculations and graphs required per testing standards
- Provides advanced graphing capabilities
- Provides full-unit customization
- Reports can also be exported to Excel or a CSV file, if desired, and, we can provide custom integration/export solutions for LIMS, EQulS, gINT, etc.

Humboldt's NEXT Basic software is used to control the operation of Humboldt's testing machines, as well as provide data acquisition and reporting of test data. The software provides a computer-based platform with the ability to configure testing machines and the testing process; calibrate transducers, load cells and digital indicators; specify testing parameters and limits, operate the machine during the testing and provide detailed reports of the data collected in tabular or graphical formats.

From controlling a single operation to a complete geotechnical lab, Humboldt's NEXT Basic data acquisition software, in conjunction with compatible Humboldt testing equipment, provides a complete solution for the acquisition, recording and presentation of test data. NEXT Basic software is included with many of Humboldt's load frames, consolidation and direct shear machines; providing robust machine control, calibration, data acquisition and report generation for those using a computer to control load frame operations.

With Humboldt's NEXT Basic software, operators have the ability to view and control testing operations from a PC in the lab, in the next room or at a different location, as well as the ability to control and monitor multiple tests at the same time.

So, whether you are controlling a single testing operation or controlling a complete geotechnical lab, Humboldt's NEXT Basic software, in conjunction with Humboldt's testing machines, provides a complete solution for the calibration, acquisition, recording and presentation of testing data in data tabulation and graphic chart formats.

# NEXT Test-Specific Software Modules

Humboldt NEXT Basic software can be enhanced with the purchase of test-specific modules. These modules provide you with the following capabilities beyond the standard software included with your ELITE Series load frames.

- Test-specific setup, which guides you through the process and includes selecting data collection parameters that best fit the specific test
- Input specific project information for each test, such as project name, client information, etc
- All test-specific initial, intermediate, and final parameters required by ASTM and BS standards are dynamically calculated for you, based on your input of specimen information, such as size, weight, etc
- Tabulated test data, graphs and all test-specific calculations are provided in real time, allowing you to monitor tests in process
- Generate test-specific reports that include all graphs and data presented in a project
- Simultaneously run multiple tests on one computer, involving any of the available NEXT modules and any compatible Humboldt equipment up to 255 device connections, which is up to 1020 inputs
- Create and store test-specific test setup templates for rapid setup of future tests
- Produce test-specific graphs, which allow you to draw construction lines to calculate angles and other test-specific parameters
- Automatically recover from a PC shutdown without loss of data
- All unit parameters can be adjusted individually
- Easily change between different test standards
- Access free, down loadable software upgrades for purchased modules
- Additional modules are available, please inquire

Consolidation Module	HM-5100SW
Direct Shear Module	HM-5700SW
CBR/LBR Module	HM-5001SW
Unconsolidated Undrained (UU) Module	HM-5002SW
Consolidated Undrained (CU) Module	HM-5003SW
Unconfined Compression (UC) Module	HM-5004SW
Consolidated Drained (CD) Module	HM-5006SW
Marshall Module	HM-5005SW
Permeability Module	HM-5007SW

**YOU CAN PURCHASE AND REGISTER YOUR SOFTWARE MODULES ONLINE!**  
<https://www.humboldtmg.com/next-software-modules.html>

CBR/LBR Module, HM-5001SW

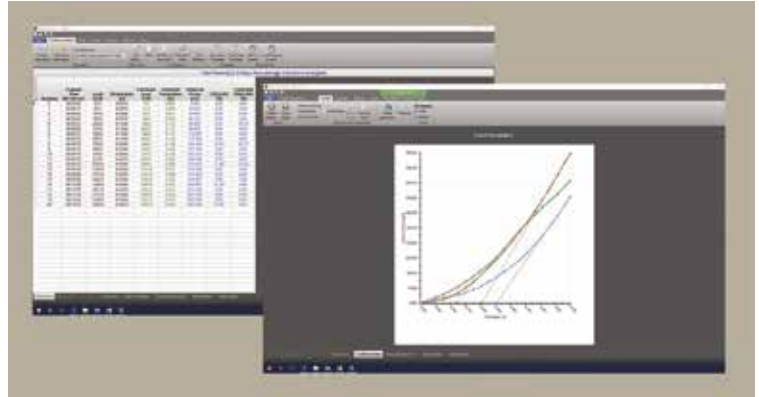

Unconsolidated Undrained (UU) Module, HM-5002SW

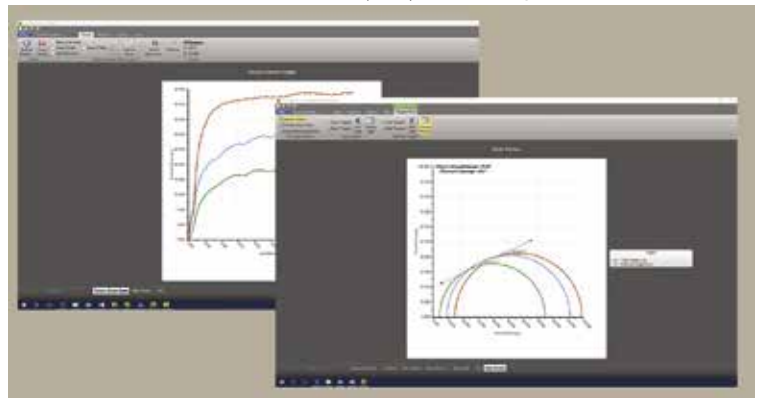

Consolidated Undrained (CU) Module, HM-5003SW

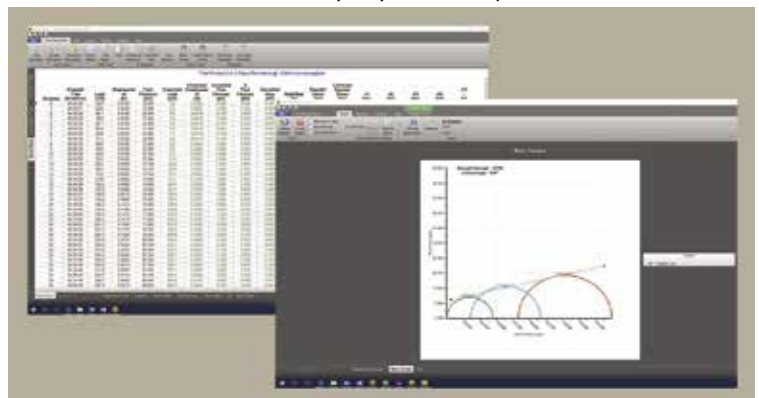

Unconfined Compression (UC) Module, HM-5004SW

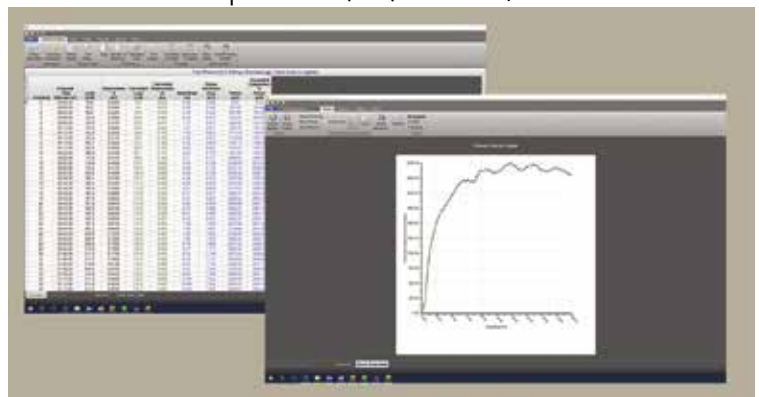

# ELITE SERIES

## Automated Consolidation



HM-5470.3F

### ConMatic IPC, Automated Consolidation System

ASTM: D2435, D4546, AASHTO: T216, BS:1377:5

The HM-5470.3F ConMatic IPC is a fully-automated, incremental pressure controller for performing incremental consolidation and one-dimensional swell tests. The ConMatic IPC allows consolidation, constant load and volume swell tests to be run automatically, freeing up technicians for other tasks and reducing the duration of the testing procedures by more than half—effectively saving time and manpower and increasing lab profitability. One ConMatic IPC automated system can replace the production of several manual machines—running incremental consolidation tests according to ASTM D2435 Method B, where successive load increments are applied after 100% primary consolidation.

Once a sample has been placed onto the test platform and the test conditions set, the ConMatic IPC performs all consolidation tests, including moving to the next stress level, without operator

assistance. The system automatically moves through the different test parameters specified by the user with incremental consolidation tests typically being completed in 24 to 48 hours. The Humboldt NEXT software with the HM-5100SW Consolidation module uses sample deformation readings taken from the displacement transducer and load readings from the load cell to maintain a constant applied stress or strain to the sample through the use of a digital pressure regulator. Test results are recorded and rendered in real-time on the computer screen while test data is stored and calculations are performed automatically. Humboldt's NEXT software with the HM-5100SW Consolidation module provides:

- Live test data tabulation and live graphing capabilities (real-time)
- Complete test reporting including all calculations and graphs required for testing
- Review and exporting of tests using Microsoft Excel
- Smart Test Function: automatically picks up where it left off if the test was not finished due to unexpected events within your computer

The unique design of the ConMatic IPC system enables the user to connect multiple ConMatic IPC units to a single computer and run them independently and simultaneously when connected via a LAN-network..



### NOTES

Includes Humboldt NEXT Software HM-5100SW Consolidation-specific Module

### Controller Specifications:

Display (Resistive Touch)	7" (178mm) VGA (480 x 800)
Real-time test data	Graphic and tabulation
Processor	Dual 32-bit ARM
RAM	64MB
Memory, non-volatile	4GB
Analog to digital converter	24 bit
Data acquisition	2 Channels
Logging speed	up to 50 readings per second
Multi-test storage	1000
Points per test	3000
USB port (front)	export data, import/export calibration data, WiFi
USB port (back)	provides external power for wireless access point
Ethernet connection	for network connectivity
24-bit differential analog to digital converter	2
Ambient temperature sensor	1
Firmware Update	Ethernet or flash drive



HM-5470.3F

**UPGRADE**  
 Upgrade your Humboldt HM-2470.3F to the new HM-5470.3F, order HM-5470U.

Specifications:	
Sample size	up to 4" (100mm)
Maximum load	2200lbf (10kN)
Clearance, vertical	8.25" (210mm)
Clearance, horizontal	7.75" (197mm)
Maximum piston travel	0.5" (12.7mm)
Dimensions (L x W x H)	12" x 12" x 30" (305 x 305 x 762mm)
ConMatic IPC System Requirements	
AC Supply	110/220 VAC 50/60 Hz 5 Amp
Air Supply	Clean and dry (air filter, water trap), minimum: 100psi (700kps) continuous air supply 10CFM (0.3m <sup>3</sup> /min)

**Computer Control**

NEXT software and the enhanced Consolidation module, HM-5100SW, is included with the ConMatic IPC automated consolidation machine. This software provides robust machine control, calibration, data acquisition and report generation for those using a computer to control consolidation testing operations.

In addition, operators have the ability to view and control testing operations from a PC in the lab, in the next room or at a different location, while also providing report generating capabilities using the consolidation test-specific software module.

So, whether you are controlling a single consolidation machine, controlling multiple machines, or even a complete geotechnical lab, Humboldt's NEXT software, in conjunction with Humboldt's ConMatic IPC, provides a complete solution for the acquisition, recording and presentation of consolidation testing data in data tabulation and graphic chart formats.

- Machine control, and data acquisition via networked computer
- Provides the ability to use Humboldt's Next Software's, advanced test-specific modules
- Real-time graphical chart and numerical display of tests via computer display
- Effective sampling rate of 50 readings per second
- Stores unlimited tests with up to 3000 points per test.
- Up to 255 individual tests can be run simultaneously from a single PC
- Provides advanced graphing capabilities
- Provides full-unit customization
- Reports can also be exported to Excel or a CSV file, if desired, and we can provide custom integration/export solutions for LIMS, EQuIS, gINT, etc.

ConMatic IPC, 120/220V 50/60Hz **HM-5470.3F**  
 Shipping wt. 52 lbs (23.85kg)

The HM-5470.3F ConMatic IPC includes:	
(1) S-type load cell 2,000 lbs (10kN) with 0.75" adapter	HM-2300.20
(1) Linear strain transducer, 1.0" (25mm)	HM-2310.10
5/8" Stainless Pressure Ball	HM-001076
(1) NEXT consolidation software module	HM-5100SW

**Typical HM-5470.3F Consolidation Setup:**

Part #	Description
HM-5470.3F	ConMatic IPC
Required Components, Order Separately	
HM-1220.XX*	Fixed ring consolidation cell

\* XX Requires a sample size designation, see page 111 for choices

Additional Items Required	
PC computer	not supplied
Refrigeration Dryer	HM-4221
Desiccant Dryer, Silica Gel	HM-4222
Filter/Regulator	HM-4223
Consolidation Installation Kit	HM-4168
25' of 1/4" Tubing	HM-4196.25 (sold by the foot)
Filter Kit for Controller	HM-200926





# Pneumatic Consolidation

## ConMatic Pneumatic Consolidation Machine

ASTM: D2435, D4546, AASHTO: T216, BS:1377:5

Compact and easy-to-use, the HM-5432.3F pneumatic consolidation load frame is used to estimate the rate and amount of settlement anticipated for a proposed structure. The unit applies loads instantly without impact for stress-controlled consolidation testing; and, maintains the load regardless of sample compression. Its small footprint saves valuable lab counter space while maintaining its versatility by supporting fixed ring, floating ring, or permeability cells.

### Features include:

- Highly-sensitive accuracy in lower load ranges
- Integral digital readout simplifies checking applied load and setup of predetermined load
- Adjustable upper cross beam
- Instantaneous loading without impact
- Flexible load choice
- Not sensitive to shock
- Choice of English or Metric models

The HM-5432's digital readout displays applied loads with the help of precision pressure regulators and pressure transducers with a linearity of  $\pm 0.1\%$ . The 1" (25.4mm) thick aluminum platforms have centering pads and accept any consolidation ring up to 4.0" (100.0mm) in diameter. Stainless steel vertical rods support the cross-head and dial gauge. One HM-001076- Pressure Ball is included with the unit. Air supply tubing (25') to hook up the compressed air line is also included. The unit features a durable enamel, powder-coated steel cabinet which protects the internal components.

Specifications:	
Sample size	up to 4" (100mm)
Maximum load	2200lbf (10kN)
Clearance, vertical	8.25" (210mm)
Clearance, horizontal	7.75" (197mm)
Maximum piston travel	0.5" (12.7mm)
Dimensions (L x W x H)	12" x 12" x 30" (305 x 305 x 762mm)
ConMatic System Requirements	
AC Supply	110/220 VAC 50/60 Hz 5 Amp
Air Supply	Clean and dry (air filter, water trap), minimum: 100psi (700kps) continuous air supply 10CFM (0.3m <sup>3</sup> /min)

The HM-5432 can be used with a standard mechanical dial gauge setup or, for data acquisition applications, it can be teamed with digital indicators or strain transducers (LSCT) and coupled to one of the Humboldt's data loggers. For additional data acquisition capabilities add Humboldt's NEXT HM-5100SW Consolidation-specific module and a computer for enhanced data acquisition and report capabilities. **The HM-5432.3F only includes the basic unit, order gauges and cells separately.**

ConMatic TSF, 120/220V 50/60Hz      HM-5432.3F  
 ConMatic kgf/cm<sup>2</sup>, 120/220V 50/60Hz      HM-5432M.3F  
Shipping wt. 48 lbs (21.7kg)

### Typical HM-5432.3F Consolidation Setup:

Part #	Description
HM-5432.3F	ConMatic 32 TSF
HM-5432M.3F	ConMatic 32 Kgf/cm <sup>2</sup>
Required Components, Order Separately	
HM-1220.XX	Fixed ring consolidation cell
HM-001076	5/8" Pressure Ball (Stainless)
H-4471CC	Dial gauge, 0.5" X .0001" CC
H-4465.12CC	Dial gauge, 12 X 0.002mm CC

\* XX Requires a sample size designation, see page 111 for choices



HM-5432.3F

**UPGRADE**

Upgrade your Humboldt HM-2432A.3F to the NEW HM-5432.3F, order HM-5432U.



# Dead-Weight Consolidation



HM-1100A

### Dead-Weight Consolidation Frame

ASTM: D2435, D4546, AASHTO: T216, BS:1377:5  
 Able to survive in even the harshest laboratory environments, the HM-1100A will provide you with reliable service day-in and day-out. The design features a rugged frame manufactured from aluminum with stainless steel vertical rods, horizontal cross arms and beam support rods. The load arm incorporates 9:1, 10:1, and 11:1 beam ratios for greater flexibility and loading weight requirements. Using the 10:1 ratio on 2.5" (63 mm) diameter samples, the system is capable of producing loads up to 48 tsf (4,597 kPa).

- Triple beam ratios minimize loading weight requirements
- 48 tsf (5,148 kPa) maximum load capacity
- Aluminum and stainless steel construction for corrosion resistance and long life
- Wide range of consolidation cells available in fixed ring, floating ring, permeability and back-pressure designs
- Loading weights available in both, tsf and kg versions
- **Basic unit does not include a dial indicator, order separately, see page 148**
- The HM-1100A can also be paired with our Data Loggers with digital indicators or strain transducers (LSCT). See next page.

Dead-Weight Consolidation Frame HM-1100A  
 Shipping wt. 75 lb (34kg)

Specifications	
Load Capacity	48 tsf (4,597 kPa)
Beam Ratios	9:1, 10:1 and 11:1
Frame Construction	Heavy-duty aluminum frame with stainless steel vertical, horizontal and beam support rods
Cell Platform	Anodized aluminum with locating pins for centering cells.
Dimension (W x D x H)	7.75" x 32" x 19.5" (197 x 812 x 495 mm)
Weight	47 lbs. (21kg)

### Consolidation (Dead-Weight) Typical Setups:

Part #	Description
Dead weight consolidation	
HM-1100A	Dead weight consolidation frame-front load
HM-1120* or HM-1123	Weight set, 16 TSF or Weight set, 64kg
HM-1220.XX	Fixed ring consolidation cell
H-4471CC or H-4465.12CC	Dial gauge, 0.5" X .0001" CC or (12 x 0.002mm) CC

\* XX Requires a sample size designation, see page 111 for choices



HM-1100.1

HM-1100.3

### Consolidation Frame Stands

Butcher block table-top with heavy-duty, steel frame designed to provide stable mounting platform for HM-1100A consolidation frames. Consolidation frames can also be bolted to the table and the table can be bolted to floor for increased stability.

Single-Station Frame Stand HM-1100.1  
 Triple-Station Frame Stand HM-1100.3  
 Shipping wt. HM-1100.1: 50 lb (23kg),  
 HM-1100.3: 115 lb (52.1kg)



DATA ACQUISITION SETUPS FOR SEMI-AUTOMATIC AND DEAD-WEIGHT CONSOLIDATION

Data Acquisition and Control for both the HM-5432 semi-automatic consolidation machine and the HM-1100A dead-weight consolidation frame can be achieved with the use of one of Humboldt's 4-channel data loggers. The touch-screen monitor of the data logger provides test control and live test monitoring in either a stand-alone or computer-controlled configuration.

In the case of the HM-5432, pneumatic loads are controlled by manual valve controls located on the front panel of the consolidation machine. With the HM-1100A dead-weight loads are controlled by physically adding weights to the consolidation frame. With both machines, the data logger provides four (4) integral and independent data acquisition channels, which can be utilized in stand-alone configurations or accessed through a LAN-networked computer using Humboldt's NEXT Basic software.

**Stand-Alone Test Monitoring**

The touch-screen controller provides you with full, graphical monitoring of testing functions in a stand-alone application. The seven-inch, waterproof screen on the Humboldt Data Loggers provides at-a-glance monitoring of testing functions, in a real-time graphical display, without the use of a computer, building upon Humboldt's dedication to modular, stand-alone data acquisition.

Now, in a stand-alone application, you will be able to run tests and display results while viewing tabulation, basic x-y graphs and instrument readings in real-time during the test, using user-defined, basic data acquisition. Test data is stored in the device and can be downloaded to a USB drive via the machine's FRONT USB port or the data can be transferred to a computer via the LAN port.

- 4-channel data acquisition
- Hi-res, 7", waterproof, touch-screen provides total control and real-time graphical display of tests
- Machine/Test control and data acquisition via touch-screen

**Computer Test Monitoring**

Humboldt's NEXT Basic software can be downloaded from: <https://www.humboldtmg.com/support/software.php> for use with a Humboldt data logger and computer. This software provides basic data acquisition and report generation for those using a computer for this purpose.

In addition, you can purchase Humboldt's HM-5100SW Consolidation module for consolidation test-specific set up and monitoring of the testing function.

- Data acquisition via a networked computer
- Provides the ability to use Humboldt's NEXT Software's HM-5100SW consolidation module
- Real-time graphical chart and numerical display of tests via computer display
- Effective sampling rate of 50 readings/sec.
- Stores unlimited tests with up to 3000 points per test.

**ConMatic Semi-Automatic Consolidation Machine**



**Humboldt Dead-weight Consolidation Frame**



**Analog Data Acquisition Setup**

Data acquisition setup for Pneumatic consolidation using analog transducer and Logger

HM-5432.3F or HM-5432M.3F	ConMatic 32 TSF or ConMatic 32 Kg/cm <sup>2</sup>
HM-1220.XX	Fixed ring consolidation cell
HM-2310.04	Strain transducer 0.4" (10mm)
HM-2310BR	Strain transducer bracket
HM-5320.3F	Humboldt Logger 4 channel analog data acquisition
HM-5100SW	NEXT consolidation module

**Digital Data Acquisition Setup**

Data acquisition setup for Pneumatic consolidation using digital indicator and Logger

HM-5432.3F or HM-5432M.3F	ConMatic 32 TSF or 32 Kg/cm <sup>2</sup>
HM-1220.XX	Fixed ring consolidation cell
HM-4470.10	Digital indicator 1" x .0001" (25 x 0.002 mm)
HM-4470C	Digital Indicator Cable, 6 ft.
HM-5330.3F	Humboldt Logger 4 channel digital data acquisition
HM-5100SW	NEXT consolidation module

\* XX Requires a sample size designation, see page 111 for choices

**Analog Data Acquisition Setup**

Data acquisition setup for Dead-weight consolidation using analog transducer and Logger

HM-1100A	Dead weight consolidation frame
HM-1120 or HM-1123	Weight set, 16 TSF Weight set, 64 kg
HM-1220.XX	Fixed ring consolidation cell
HM-2310.04	Strain transducer 0.4" (10mm)
HM-2310BR	Strain transducer bracket
HM-5320.3F	Humboldt Logger 4 channel analog data acquisition
HM-5100SW	NEXT consolidation module

**Digital Data Acquisition Setup**

Data acquisition setup for Dead-weight consolidation using digital indicator and Logger

HM-1100A	Dead weight consolidation frame
HM-1120 or HM-1123	Weight set, 16 TSF Weight set, 64 kg
HM-1220.XX	Fixed ring consolidation cell
HM-4470.10	Digital indicator 1" x .0001" (25 x 0.002 mm)
HM-4470C	Digital Indicator Cable, 6 ft.
HM-5330.3F	Humboldt Logger 4 channel digital data acquisition
HM-5100SW	NEXT consolidation module

\* XX Requires a sample size designation, see page 111 for choices



### Fixed Ring Consolidation Cell

ASTM: D2435, D4546, AASHTO: T216, BS:1377:5  
 Complete cell assembly features stainless steel construction and self-trimming cutter ring. Cutter ring rests inside clamping ring on lower porous stone, which is larger than the sample. The top porous stone and loading pad rest on the sample. The assembly is fixed on the cell base and enclosed within an acrylic cylinder open to the atmosphere, which permits saturation of the sample. The cell comes complete with all the parts illustrated in the drawing below.

Fixed Ring Consolidation Cell **See Chart**  
 Shipping wt. 9 lb (4kg)



Fixed Ring Consolidation Cell	
2.0"	HM-1220.20
2.42"	HM-1220.242
2.5"	HM-1220.25
3.0"	HM-1220.30
4.0"	HM-1220.40
50mm	HM-1220.50
70mm	HM-1220.70
75mm	HM-1220.75
100mm	HM-1220.100

### Floating Ring Consolidation Cell

ASTM: D2435, D4546, AASHTO: T216, BS:1377:5  
 Complete cell assembly features stainless steel construction with self-trimming cutter ring. Similar in construction to a fixed ring cell with the exception that the lower porous stone fits inside the cutter ring and can move vertically within it. The sample ring is also free to move vertically. The cell comes complete with all the parts illustrated in the drawing below.

Floating Ring Consolidation Cell **See Chart**  
 Shipping wt. 6 lb (2.27kg)



Floating Ring Consolidation Cell	
2.0"	HM-1210.20
2.42"	HM-1210.242
2.5"	HM-1210.25
3.0"	HM-1210.30
4.0"	HM-1210.40
50mm	HM-1210.50
70mm	HM-1210.70
75mm	HM-1210.75
100mm	HM-1210.100

### Fixed Ring Permeability Cell

ASTM: D2435, D4546, AASHTO: T216, BS:1377:5  
 Similar in construction to a fixed ring cell with the exception that the saturated sample and water are sealed from the atmosphere. Complete cell assembly features stainless steel construction and self-trimming cutter ring. Base features outlet port and 10cc pipette for monitoring water level. The cell comes complete with all the parts illustrated in the drawing below, as well as a pipette.

Fixed Ring Permeability Cell **See Chart**  
 Shipping wt. 12 lb (5.4kg)



Fixed Ring Permeability Cell	
2.0"	HM-1230.20
2.42"	HM-1230.242
2.5"	HM-1230.25
3.0"	HM-1230.30
4.0"	HM-1230.40
50mm	HM-1230.50
70mm	HM-1230.70
75mm	HM-1230.75
100mm	HM-1230.100

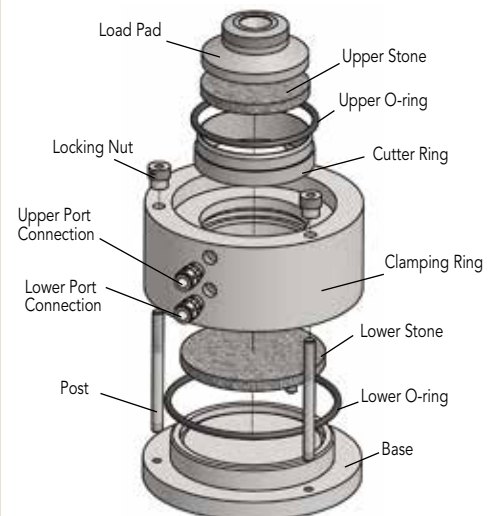
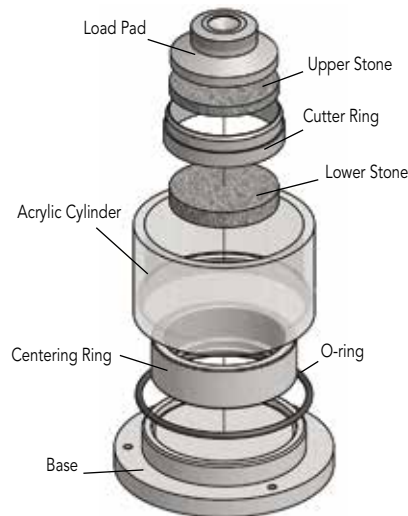
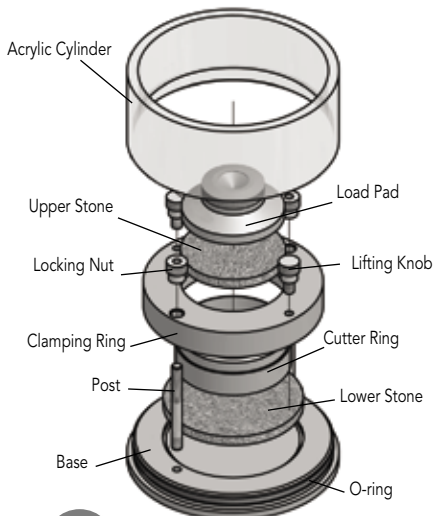

### NOTES

See next page for component details



Load Pad	
2"	HM-1220.20.10
2.42"	HM-1220.24.10
2.5"	HM-1220.25.10
3.0"	HM-1220.30.10
4.0"	HM-1220.40.10
50mm	HM-1220.50.10
70mm	HM-1220.70.10
75mm	HM-1220.75.10
100mm	HM-1220.100.10



Upper Stone	
2"	HM-4184.1985
2.42"	HM-4184.240
2.5"	HM-1220.25.11 (stud)
2.5"	HM-4184.2485
3.0"	HM-4184.2985
4.0"	HM-4184.3985
50mm	HM-4184.1955
70mm	HM-4184.274
75mm	HM-4184.2940
100mm	HM-4184.3925



Lower Stone (floating)	
2"	HM-4184.1985T
2.42"	HM-4184.240T
2.5"	HM-4184.2485T
3.0"	HM-4184.2985T
4.0"	HM-4184.3985T
50mm	HM-4184.1955T
70mm	HM-4184.274T
75mm	HM-4184.2940T
100mm	HM-4184.3925T



Lower Stone (fixed, permeability)	
2"	HM-4184.331
2.42"	HM-331
2.5"	HM-4184.331
3.0"	HM-4184.331
4.0"	HM-4184.4375T
50mm	HM-4184.331
70mm	HM-4184.331
75mm	HM-4184.331
100mm	HM-4184.4375T



Acrylic Cylinder (fixed-floating)	
2"	HM-1220.25.2
2.42"	HM-1220.25.2
2.5"	HM-1220.25.2
3.0"	HM-1220.25.2
4.0"	HM-1220.40.2
50mm	HM-1220.25.2
70mm	HM-1220.25.2
75mm	HM-1220.25.2
100mm	HM-1220.40.2



Centering Ring (floating)	
2"	HM-1210.20.12
2.42"	HM-1210.24.12
2.5"	HM-1210.25.12
3.0"	HM-1210.30.12
4.0"	HM-1210.40.12
50mm	HM-1210.50.12
70mm	HM-1210.70.12
75mm	HM-1210.75.12
100mm	HM-1210.100.12



Clamping Ring (permeability)	
2"	HM-1230.20.9
2.42"	HM-1230.24.9
2.5"	HM-1230.25.9
3.0"	HM-1230.30.9
4.0"	HM-1230.40.9
50mm	HM-1230.50.9
70mm	HM-1230.70.9
75mm	HM-1230.75.9
100mm	HM-1230.100.9



Clamping Ring (fixed)	
2"	HM-1220.20.9
2.42"	HM-1220.24.9
2.5"	HM-1220.25.9
3.0"	HM-1220.30.9
4.0"	HM-1220.40.9
50mm	HM-1220.50.9
70mm	HM-1220.70.9
75mm	HM-1220.75.9
100mm	HM-1220.100.9



Base (floating/permeability)	
2"	HM-1230.25.1
2.42"	HM-1230.25.1
2.5"	HM-1230.25.1
3.0"	HM-1230.25.1
4.0"	HM-1230.40.1
50mm	HM-1230.25.1
70mm	HM-1230.25.1
75mm	HM-1230.25.1
100mm	HM-1230.40.1



Base (fixed)	
2"	HM-1220.25.1
2.42"	HM-1220.25.1
2.5"	HM-1220.25.1
3.0"	HM-1220.25.1
4.0"	HM-1220.40.1
50mm	HM-1220.25.1
70mm	HM-1220.25.1
75mm	HM-1220.25.1
100mm	HM-1220.40.1



Cutting Ring (all)	
2"	HM-1220.20.8
2.42"	HM-1220.24.8
2.5"	HM-1220.25.8
3.0"	HM-1220.30.8
4.0"	HM-1220.40.8
50mm	HM-1220.50.8
70mm	HM-1220.70.8
75mm	HM-1220.75.8
100mm	HM-1220.100.8



Calibration Disk	
2"	HM-1220.20.4
2.42"	HM-1220.24.4
2.5"	HM-1220.25.4
3.0"	HM-1220.30.4
4.0"	HM-1220.40.4
50mm	HM-1220.50.4
70mm	HM-1220.70.4
75mm	HM-1220.75.4
100mm	HM-1220.100.4



Lower o-ring (floating/permeability)	
2"	HM-003053
2.42"	HM-003053
2.5"	HM-003053
3.0"	HM-003053
4.0"	HM-003056
50mm	HM-003053
70mm	HM-003053
75mm	HM-003053
100mm	HM-003056



Lower o-ring (fixed)	
2"	HM-003052
2.42"	HM-003052
2.5"	HM-003052
3.0"	HM-003052
4.0"	HM-003024
50mm	HM-003052
70mm	HM-003052
75mm	HM-003052
100mm	HM-003024



Upper o-ring (permeability)	
2"	HM-003057
2.42"	HM-003058
2.5"	HM-003054
3.0"	HM-003059
4.0"	HM-0030604
50mm	HM-003057
70mm	HM-003061
75mm	HM-003062
100mm	HM-003063



Filter Paper	
2"	HM-4189.20
2.42"	HM-4189.25
2.5"	HM-4189.25
3.0"	HM-4189.30
4.0"	HM-4189.40
50mm	HM-4189.20
70mm	HM-4189.28
75mm	HM-4189.30
100mm	HM-4189.40



Post	
ALL	HM-1220.25.3



Locking Nut	
ALL	HM-1220.25.5



Lifting Knob	
ALL	HM-1220.25.6



5/8" Pressure Ball (Stainless)	
ALL	HM-001076



HM-4168

**Shear & Consolidation Install Kit Components**

.25" OD Tubing, 100ft.	HM-4196.25
.375" to .25" Reducer Bushing (3)	HM-4150.77
Cutter, Flexible Tubing (1)	HM-000058
Thread Tape, PTFE (1)	HM-000059
Wrench, Adjustable, 6" (1)	HM-000064
Union T Fitting, .25" (5)	HM-4150.45
Quick Valve Coupling, .25" (2)	HM-4150.72
Regulator Elbow, .25" (3)	HM-4150.44
Tube Fitting T, 6mm OD (5)	HM-003175
Push-to-Connect Tube Fitting Coupler, .25" OD (4)	HM-003176

**Shear & Consolidation Installation Kit**

Kit designed to provide fittings, connectors, tubing and tools to complete a triaxial set up installation. Kit includes items in the table below. All items can be purchased individually as well.

**Shear & Consolidation Installation Kit** HM-4168  
Shipping wt. 4.5 lbs (2.04kg)



Port Connection Upper (Permeability)	
ALL	HM-003027



Port Connection Lower (Permeability)	
ALL	HM-003055



HM-1240.25

**Trimming Turntable for 2.5" Consolidation Specimens**

Trims samples down to correct sizing.

**Trimming Turntable, 2.5" Consolidation** HM-1240.25

Shipping wt. 5lb (2.27kg)

**Weight Sets for Consolidation and Direct Shear Testing**

Weight Set	Set Includes	Model No.	Ship. Wt.
<b>16 TSF Set</b>	includes: (2) .125 TSF, (1) .25 TSF, (1) .50 TSF, (1) 1.0 TSF, (1) 2.0 TSF, (3) 4.0 TSF weights	HM-1120	140 lbs. (64kg)
<b>32 TSF Set</b>	includes: (2) .125 TSF, (1) .25 TSF, (1) .50 TSF, (1) 1.0 TSF, (1) 2.0 TSF, (7) 4.0 TSF weights	HM-1121	275 lbs. (125kg)
<b>32 kg Set</b>	includes: (4) 1 kg, (3) 4 kg, (2) 8 kg weights	HM-1122	73 lbs. (33.1kg)
<b>50 kg Set</b>	includes: (3) 1 kg, (1) 2 kg, (1) 5 kg, (4) 10 kg weights	HM-1125	110 lbs. (50kg)
<b>64 kg Set</b>	includes: (4) 1 kg, (5) 4 kg, (5) 8 kg weights	HM-1123	150 lbs. (68kg)
<b>88 kg Set</b>	includes: (4) 1 kg, (5) 4 kg, (8) 8 kg weights	HM-1124	130 lbs. (59kg)



HM-1120

**Individual Weights for Consolidation and Direct Shear Testing**

Individual Weights: Kg	
Weight	Model No.
0.5kg	HM-1122.05
1.0kg	HM-1122.1
2.0kg	HM-1122.2
4.0kg	HM-1122.4
5.0kg	HM-1122.5
8.0kg	HM-1122.8
10.0kg	HM-1122.10

Individual Weights: TSF	
Weight	Model No.
0.125 (1/8)	HM-1120.125
0.25 (1/4)	HM-1120.250
0.50 (1/2)	HM-1120.500
1.0	HM-1120.1
2.0	HM-1120.2
4.0	HM-1120.4

# ELITE SERIES Automated Direct Shear

**Pneumatic Direct/Residual Shear Apparatus**

ASTM: D3080; AASHTO: T236, BS:1377:7

The Humboldt HM-5760 Direct/residual shear apparatus, utilizes pneumatic loading to apply vertical loads to a soil sample— eliminating the need for loading weights used in dead weight-type systems.

The HM-5760 is a microprocessor-based machine featuring a stepper-motor drive system and a 7" touch-screen display that allows the operator to control and monitor all test functions. Like all Humboldt Elite series machines, the HM-5760 is built with durable, high-quality components and features the use of a stepper motor, precision gears and gear box to ensure smooth and reliable operation, as well as precise results.

The HM-5760 is built around Humboldt's integral, 4-channel data logger with touch-screen control, which allows the HM-5760 to be used as a standalone device capable of full test control and data logging. It can also be controlled by a networked computer at any location with access to the network.

In stand-alone mode, the HM-5760 direct shear machine provides a 7" (178mm) touch-screen controller, giving you finger-tip control of your testing processes, as well as providing real-time, visual views of your data in both tabular and graphic formats. The waterproof, touch screen provide s colorful, at-a-glance monitoring of testing functions without the use of a computer. Operators can see all the data in several formats at the machine

while the test is running. Data can then be viewed simultaneously or downloaded later to a computer in the lab, in the next room or at a different location, while also providing report generation capabilities from within Humboldt's NEXT software or our enhanced HM-5700SW Direct Shear Reporting Software.

When operated from a networked computer the NEXT software provides robust machine and test control, and report generation. It also provides the ability to control and monitor multiple machines from a single computer.

**NOTES**

Counter-balance device for ASTM D3080 compliance. Not available anywhere else. Also available as a retrofit kit. HM-2560A.1

The HM-5760 is supplied complete with a 2,000 lbf (10kN) capacity load cell; 1" (25.4mm) horizontal strain transducer, and a 0.4" (10.2mm) vertical strain transducer. Humboldt's HM-5700SW NEXT Direct Shear software module is also included. **Shear box assemblies and related accessories are not included and should be ordered separately.**

Humboldt's exclusive, counter-balance device for ASTM D3080 compliance is included with the HM-5760.

Pneu. Direct/Residual Shear Apparatus **HM-5760.3F**  
Shipping wt. 168 lb (76kg)

**HM-5760.3F Specifications:**

Horiz. movement	2" (50mm) Maximum
Horiz. shear force	2000 lbf (10kN)
Vertical load	2000 lbf (10kN)
Data Channels	4
Speed Range	0.00001 to 0.49999 in./min. 0.00001 to 12.9999 mm/min.
Data storage	1000 tests and up to 3000 readings per test
Dimensions (L x D x H)	30" x 15.5" x 22" (760 x 394 x 558mm)
Voltage	110/220V 50/60Hz - 6.5amps

**Pneumatic Direct Shear System Requirements**

AC Supply	110/220 VAC 50/60 Hz 5 Amp
Air Supply	Clean and dry (air filter, water trap), minimum: 100psi (700kps) continuous air supply 10CFM (0.3m <sup>3</sup> /min)



HM-5760.3F



Controller Specifications:	
Display (Resistive Touch)	7" (178mm) VGA (480 x 800)
Real-time test data	Graphic and tabulation
Processor	Dual 32-bit ARM
RAM	64MB
Memory, non-volatile	4GB
Analog to digital converter	24 bit
Data acquisition	4 Channels
Logging speed	up to 50 readings per second
Multi-test storage	1000
Points per test	3000
USB port (front)	export data, import/export calibration data, WiFi
USB port (back)	provides external power for wireless access point
Ethernet connection	for network connectivity
24-bit differential analog to digital converter	2
Ambient temperature sensor	1
Firmware Update	Ethernet or flash drive



### Typical Test Setup for HM-5760

Part #	Description
HM-5760.3F	<b>Pneumatic Direct Shear with analog inputs</b> (includes a 2,000 lbf (10kN) capacity load cell; 1" (25.4mm) horizontal strain transducer, and a 0.4" (10.2mm) vertical strain transducer)
HM-5700SW	NEXT Direct Shear software module (included with HM-5760)
HM-2751.XX(S/D)	Shear box assembly (specify size)
HM-2702.XX(S/D)	Shear box cutter (specify size)
HM-2703.XX(S/D)	Dolly/tamper (specify size)

\* XX Requires a sample size designation, see page 121 for choices

### Computer Control

NEXT software and the enhanced Direct Shear module, HM-5700SW, is included with the HM-5760 pneumatic direct-shear machine. This software provides robust machine control, data acquisition and report generation for those using a computer to control consolidation testing operations.

In addition, operators have the ability to view and control testing operations from a PC in the lab, in the next room or at a different location, while also providing report generating capabilities using the consolidation test-specific software module.

So, whether you are controlling a single direct-shear machine, controlling multiple machines, or even a complete geotechnical lab, Humboldt's NEXT software, in conjunction with Humboldt's HM-5760 Direct-shear machine, provides a complete solution for acquisition, recording and presentation of direct-shear testing data in data tabulation and graphic chart formats.

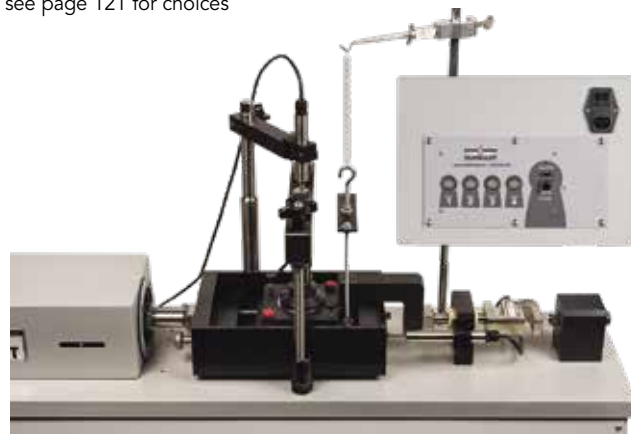

- Machine control, and data acquisition via a networked computer
- Provides the ability to use Humboldt's Next Software's, advanced test-specific modules
- Real-time graphical chart and numerical display of tests via computer display
- Effective sampling rate of 50 readings per second
- Stores unlimited tests with up to 3000 points per test.

- Up to 255 individual tests can be run simultaneously from a single PC
- Provides advanced graphing capabilities
- Provides full-unit customization
- Reports can also be exported to Excel or a CSV file, if desired, and, we can provide custom integration/export solutions for LIMS, EQuIS, gINT, etc.

Additional Items Required	
PC computer	not supplied
Refrigeration Dryer	HM-4221
Desiccant Dryer, Silica Gel	HM-4222
Filter/Regulator	HM-4223
Direct Shear/Consolidation Installation Kit	HM-4168



## Semi-Automated Direct Shear

### Pneumatic Direct/Residual Shear Apparatus

ASTM: D3080; AASHTO: T236, BS:1377:7

The HM-5755 is a semi-automatic pneumatic loading machine, which with its touch-screen monitor provides test control and live test monitoring in either a stand-alone or computer-controlled configuration. With the HM-5755, pneumatic loads are controlled by manual valve controls located on the front panel for easy use. The HM-5755 also provides four (4) integral and independent data acquisition channels, which can be utilized in stand-alone configurations or accessed through a LAN-networked computer using Humboldt's Next Software.

In stand-alone mode, the HM-5755 direct shear machine provides a 7" (178mm) touch-screen controller, giving you finger-tip control of your testing processes, as well as providing real-time, visual views of your data in both tabular and graphic formats. These new waterproof, touch screens provide colorful, at-a-glance monitoring of testing functions without the use of a computer. Operators can see all the data in several formats at the machine while the test is running. Data can then be viewed simultaneously or downloaded later to a computer in the lab, in the next room or at a different location, while also providing report generation capabilities from within Humboldt's NEXT software or our enhanced HM-5700SW Direct Shear software module.

When operated from a networked computer the NEXT software provides robust machine and test

control, and report generation. It also allows the ability to control and monitor multiple machines from a single computer.

The HM-5755 is supplied complete with a 2,000 lbf (10kN) capacity load cell; 1" (25.4mm) horizontal strain transducer, a 0.4" (10.2mm) vertical strain transducer and Humboldt's NEXT software. Shear box assemblies, **Humboldt's NEXT Direct Shear module and related accessories are not included and should be ordered separately.**

Pneumatic Direct/Residual Shear **HM-5755.3F**  
 Shipping wt. 200 lb (90.7kg)



### NOTES

Counter-balance device for ASTM D3080 compliance. Not available anywhere else. Also available as a retrofit kit. HM-2560A.1

### HM-5755.3F Specifications:

Horiz. movement	1" (25.4mm) maximum
Horiz. shear force	2000 lbf (10kN)
Vertical load	2000 lbf (10kN)
Data Channels	4
Speed Range	0.00001 to 0.49999 in./min. 0.00001 to 12.9999 mm/min.
Voltage	110/220 VAC 50/60HZ
Current	6.5 amps
Analog to digital	24 bit
Data storage	1000 tests and up to 3000 readings per test
Data collection rate	50 readings per second
Ethernet connection	for network connectivity
Dimensions (L x D x H)	30" x 15.5" x 22" (760 x 394 x 558mm)

### Pneumatic Direct Shear System Requirements

AC Supply	110/220 VAC 50/60 Hz 5 Amp
Air Supply	Clean and dry (air filter, water trap), minimum: 100psi (700kps) continuous air supply 10CFM (0.3m <sup>3</sup> /min)



HM-5755.3F

Controller Specifications:	
Display (Resistive Touch)	7" (178mm) VGA (480 x 800)
Real-time test data	Graphic and tabulation
Processor	Dual 32-bit ARM
RAM	64MB
Memory, non-volatile	4GB
Analog to digital converter	24 bit
Data acquisition	4 Channels
Logging speed	up to 50 readings per second
Multi-test storage	1000
Points per test	3000
USB port (front)	export data, import/export calibration data, WiFi
USB port (back)	provides external power for wireless access point
Ethernet connection	for network connectivity
24-bit differential analog to digital converter	2
Ambient temperature sensor	1
Firmware Update	Ethernet or flash drive

### Computer Control

NEXT software and the enhanced Direct Shear module, HM-5700SW, is included with the HM-5760 pneumatic direct-shear machine. This software provides robust machine control, data acquisition and report generation for those using a computer to control consolidation testing operations.

In addition, operators have the ability to view and control testing operations from a PC in the lab, in the next room or at a different location, while also providing report generating capabilities using the consolidation test-specific software module.

So, whether you are controlling a single direct-shear machine, controlling multiple machines, or even a complete geotechnical lab, Humboldt's NEXT software, in conjunction with Humboldt's HM-5760 Direct-shear machine, provides a complete solution for the calibration, acquisition, recording and presentation of direct-shear testing data in data tabulation and graphic chart formats.

- Machine control, and data acquisition via a networked computer
- Provides the ability to use Humboldt's Next Software's, advanced test-specific modules
- Real-time graphical chart and numerical display of tests via computer display



### Typical Test Setup for HM-5755

Part #	Description
HM-5755.3F	<b>Pneumatic Direct Shear with analog inputs</b> (includes a 2,000 lbf (10kN) capacity load cell; 1" (25.4mm) horizontal strain transducer, and a 0.4" (10.2mm) vertical strain transducer)
HM-2751.XX(S/D)	Shear box assembly (specify size)
HM-2702.XX(S/D)	Shear box cutter (specify size)
HM-2703.XX(S/D)	Dolly/tamper (specify size)

\* XX Requires a sample size designation, see page 121 for choices

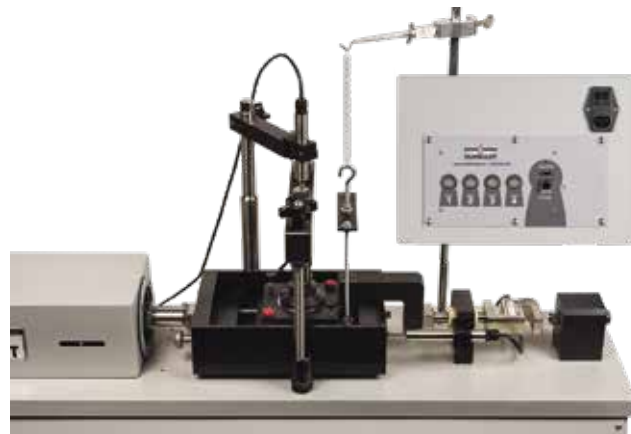

- Effective sampling rate of 50 readings per second
- Stores unlimited tests with up to 3000 points per test.
- Up to 255 individual tests can be run simultaneously from a single PC
- Provides advanced graphing capabilities
- Provides full-unit customization
- Reports can also be exported to Excel or a CSV file, if desired, and, we can provide custom integration/export solutions for LIMS, EQuIS, gINT, etc.

Additional Items Required	
PC computer	not supplied
Refrigeration Dryer	HM-4221
Desiccant Dryer, Silica Gel	HM-4222
Filter/Regulator	HM-4223
Direct Shear/Consolidation Installation Kit	HM-4168

# Dead-Weight Direct Shear

## NOTES

Counter-balance device for ASTM D3080 compliance. Not available anywhere else. Also available as a retrofit kit. HM-2560A.1



HM-5750A.3F



HM-5750D.3F



HM-5750.3F

The HM-5750 Series of Dead-weight Direct-shear machines, come in three configurations — analog, digital and manual gauge measuring devices. These machines feature Humboldt's touch-screen monitor for test control. In addition, Models HM-5750A and HM-5750D provide four (4) integral and indepen-

dent data acquisition channels, which can be utilized in stand-alone configurations or accessed through a LAN-networked computer using Humboldt's Next Software for control and data collection.

### Direct/Residual Shear Apparatus, Analog

ASTM: D3080; AASHTO: T236, BS:1377:7

The HM-5750A Direct Shear machine is an economical choice for performing direct/residual shear tests utilizing the dead-weight method and analog measuring devices. The microprocessor-based system features a stepper-motor drive system and a 7" touch-screen display that allows the operator to control and monitor all test functions.

Like all Elite Series machines, the HM-5750A is built around Humboldt's integral, 4-channel data logger with touch-screen control, which allows the HM-5750A to be used as a stand-alone device capable of full test control and data logging. It can also be controlled by a networked computer at any location with access to the network. The carriage accepts shear box squares up to 4.0" (100mm) internal dimension. Forward and reverse measurements permit residual shear testing as standard. A built-in safety feature prevents the overloading of the load measuring system.

The HM-5750A is supplied complete with a 2,000 lbf (10kN) capacity load cell; 1" (25.4mm) horizontal strain transducer, and a 0.4" (10.2mm) vertical strain transducer. Shear box assemblies and related accessories are not included and should be ordered separately. (See page 121)

Direct Shear Apparatus, Analog **HM-5750A.3F**  
 Shipping wt. 330 lb (149kg)

### Direct/Residual Shear Apparatus, Digital

ASTM: D3080; AASHTO: T236, BS:1377:7

The HM-5750D Direct Shear machine is an economical choice for performing direct/residual shear tests utilizing the dead-weight method and digital measuring devices. The microprocessor-based system features a stepper-motor drive system and a 7" touch-screen display that allows the operator to control and monitor all test functions.

Like all Elite Series machines, the HM-5750D is built around Humboldt's integral, 4-channel data logger with touch-screen control, which allows the HM-5750D to be used as a stand-alone device capable of full test control and data logging. It can also be controlled by a networked computer at any location with access to the network. The carriage accepts shear box squares up to 4.0" (100mm) internal dimension. Forward and reverse measurements permit residual shear testing as standard. A built-in safety feature prevents the overloading of the load measuring system.

The HM-5750D is supplied complete with a 2,200 lbf (10kN) capacity load ring and two 1.0" x 0.0001" (25.40 x 0.002mm) digital indicators. Shear box assemblies and related accessories are not included and should be ordered separately. (See page 121)

Direct Shear Apparatus, Digital **HM-5750D.3F**  
 Shipping wt. 300 lb (136kg)

### Direct/Residual Shear Apparatus, Manual

ASTM: D3080; AASHTO: T236, BS:1377:7

The HM-5750 and HM-5750M Direct Shear machines are an economical choice for performing direct/residual shear tests utilizing the dead-weight method with load rings and dial gauges.

These models include the carriage, stand, vertical load hanger and a balanced lever loading arm with a 10:1 ratio that reduces the weight required to perform tests. The micro-processor-based system features a stepper motor drive system and 7" touch-screen display.

The carriage accepts shear box squares up to 4.0" (100mm) internal dimension. Forward and reverse measurements permit residual shear testing as standard. A built-in safety feature prevents the over travel of the load measuring system.

The HM-5750 and HM-5750M are supplied complete with a 2,000 lbf (10kN) capacity load ring, 1.0" x 0.001" (25.4 x 0.01mm) and 0.5" x 0.0001" (12 x 0.002mm) dial indicator. Shear box assemblies and related accessories are not included and should be ordered separately. (See page 121)

Direct Shear Apparatus, Manual **HM-5750.3F**  
 Direct Shear Apparatus, Manual Metric **HM-5750M.3F**  
 Shipping wt. 330 lb (149kg)

## NOTES

The machines on this page do not include HM-5700SW Software

Direct Shear

# Dead-Weight Direct Shear

Specifications:	HM-5750A	HM-5750D	HM-5750	HM-5750M
Horizontal movement	2" (50mm) Maximum			
Horizontal shear force	2000 lbf (10kN)			
Vertical load	2000 lbf (10kN)			
Data Channels	3	3	0	0
Speed Range	0.00001 to 0.49999 in./min. (0.00001 to 12.9999 mm/min.)			
Data storage	1000 tests and up to 3000 readings per test	1000 tests and up to 3000 readings per test	—	—
Dimensions (L x D x H)	40" x 10" x 45" (1016 x 254 x 1143mm)			
Voltage	110/220V 50/60Hz - 6.5amps			

## Typical Test Setup for HM-5750A

Part #	Description
HM-5750A.3F	<b>Dead-weight Direct Shear with analog inputs</b> (includes a 2,000 lbf (10kN) capacity load cell; 1" (25.4mm) horizontal strain transducer, and a 0.4" (10.2mm) vertical strain transducer)
HM-5700SW	NEXT Direct Shear software module
HM-1120 or HM-1125	16 TSF or 50 kg weight set
HM-2751.XX(S/D)	Shear box assembly
HM-2702.XX(S/D)	Shear box cutter
HM-2703.XX(S/D)	Dolly/tamper



## Typical Test Setup for HM-5750D

Part #	Description
HM-5750D.3F	<b>Dead-weight Direct Shear with digital inputs</b> (a 2,200 lbf (10kN) capacity load ring and two 1.0" x 0.0001" (25.40 x 0.002mm) digital indicators)
HM-5700SW	NEXT Direct Shear software module
HM-1120 or HM-1125	16 TSF or 50 kg weight set
HM-2751.XX(S/D)	Shear box assembly
HM-2702.XX(S/D)	Shear box cutter
HM-2703.XX(S/D)	Dolly/tamper



## Typical Test Setup for HM-5750 & HM-5750M

Part #	Description
HM-5750.3F or HM-5750M.3F	<b>Dead-weight Direct Shear with load ring</b> (a 2,200 lbf (10kN) capacity load ring, 1.0" x 0.001" (25.4 x 0.01mm) and 0.5" x 0.0001" (12 x 0.002mm) dial indicator)
HM-1120 or HM-1125	16 TSF or 50 kg weight set
HM-2751.XX(S/D)	Shear box assembly
HM-2702.XX(S/D)	Shear box cutter
HM-2703.XX(S/D)	Dolly/tamper





proof screen on these Direct Shear machines provides at-a-glance monitoring of testing functions, in a real-time graphical display, without the use of a computer, building upon Humboldt's dedication to modular, stand-alone data acquisition.

Now, in a stand-alone application, you will be able to run tests and display results while viewing tabulation, basic x-y graphs and instrument readings in real-time during the test, using user-defined, basic data acquisition. Test data is stored in the device and can be downloaded to a USB drive via the machine's FRONT USB port or the data can be transferred to a computer via the LAN port.

- 4-channel data acquisition
- Hi-res, 7", waterproof, touch-screen provides total control and real-time graphical display of tests
- Machine/Test control and data acquisition via touch-screen

Humboldt's HM-5750A and HM-5750D Dead-weight Direct Shear machines provides test control and live test monitoring in either a stand-alone or computer-controlled configuration. While weights must still be loaded manually, the rest of the operation can be directed from the touch-screen monitor or a networked computer.

**Stand-Alone Test Monitoring**

The touch-screen controller provides you with full, graphical monitoring of testing functions in a stand-alone application. The seven-inch, water

Controller Specifications:	
Display (Resistive Touch)	7" (178mm) VGA (480 x 800)
Real-time test data	Graphic and tabulation
Processor	Dual 32-bit ARM
RAM	64MB
Memory, non-volatile	4GB
Analog to digital converter	24 bit
Data acquisition	3 Channels
Logging speed	up to 50 readings per second
Multi-test storage	1000
Points per test	3000
USB port (front)	export data, import/export calibration data, WiFi
USB port (back)	provides external power for wireless access point
Ethernet connection	for network connectivity
24-bit differential analog to digital converter	2
Ambient temperature sensor	1
Firmware Update	Ethernet or flash drive

**Computer Test Monitoring**

Humboldt's NEXT Basic software can be downloaded from: <https://www.humboldtmg.com/support/software.php> for use with these Humboldt Direct Shear machines. This software provides basic data acquisition and report generation for those using a computer for this purpose.

In addition, you can purchase Humboldt's HM-5700SW Direct Shear module for direct shear test-specific set up and monitoring of the testing function.



**Individual Weights for Consolidation and Direct Shear Testing**

Individual Weights: Kg		Individual Weights: TSF	
Weight	Model No.	Weight	Model No.
0.5kg	HM-1122.05	0.125 (1/8)	HM-1120.125
1.0kg	HM-1122.1	0.25 (1/4)	HM-1120.250
2.0kg	HM-1122.2	0.50 (1/2)	HM-1120.500
4.0kg	HM-1122.4	1.0	HM-1120.1
5.0kg	HM-1122.5	2.0	HM-1120.2
8.0kg	HM-1122.8	4.0	HM-1120.4
10.0kg	HM-1122.10		

**Weight Sets for Consolidation and Direct Shear Testing**

Weight Set	Set Includes	Model No.	Ship. Wt.
16 TSF Set	includes: (2) .125 TSF, (1) .25 TSF, (1) .50 TSF, (1) 1.0 TSF, (1) 2.0 TSF, (3) 4.0 TSF weights	HM-1120	140 lbs. (64kg)
32 TSF Set	includes: (2) .125 TSF, (1) .25 TSF, (1) .50 TSF, (1) 1.0 TSF, (1) 2.0 TSF, (7) 4.0 TSF weights	HM-1121	275 lbs. (125kg)
32 kg Set	includes: (4) 1 kg, (3) 4 kg, (2) 8 kg weights	HM-1122	73 lbs. (33.1kg)
50 kg Set	includes: (3) 1 kg, (1) 2 kg, (1) 5 kg, (4) 10 kg weights	HM-1125	110 lbs. (50kg)
64 kg Set	includes: (4) 1 kg, (5) 4 kg, (5) 8 kg weights	HM-1123	150 lbs. (68kg)
88 kg Set	includes: (4) 1 kg, (5) 4 kg, (8) 8 kg weights	HM-1124	130 lbs. (59kg)



Shear Box Assemblies for HM-5760, HM-5755, HM-5750	
Round	Model
2.0"	HM-2751.20D
2.42"	HM-2751.24D
2.5"	HM-2751.25D
4.0"	HM-2751.40D
50mm	HM-2751.50D
60mm	HM-2751.60D
100mm	HM-2751.100D

Shear Box Assemblies for HM-5760, HM-5755, HM-5750	
Square	Model
2.0"	HM-2751.20S
2.42"	HM-2751.24S
2.5"	HM-2751.25S
4.0"	HM-2751.40S
50mm	HM-2751.50S
60mm	HM-2751.60S
100mm	HM-2751.100S



HM-2751.25D



HM-2751.60S

**NOTES**

Shearbox assemblies include: sample box, (2) porous plates, (1) loading pad, and (1) grid plate. All shearboxes feature mounting screws for use with the HM-2750 ASTM D3080-compliant counterbalance device.



HM-2751.25D  
HM-2751.25S



HM-2702.25D



HM-1220.25D



HM-2755.25S



HM-001076



HM-003274

HM-003276



HM-4168

Accessory	Model
Cutter	HM-2702.XXS/D
Dolly tamper	HM-2703.XXS/D
Porous plate	HM-2704.XXS/D
Calibration disk, square	HM-2755.XXS
Calibration disk, round*	HM-1220.XX.4
Replacement Pressure Ball 5/8" 440 Stainless Steel	HM-001076
Screw, Black Head	HM-003274
Screw, Red Head	HM-003276
Screw	HM-003275
Plastic Retaining Screw	HM-003275A
Plastic Retaining Screw (old)	HM-2703.1

**NOTES**

Part Numbers ending in .XX require a size code to be entered referring to the sample size to be tested. For direct/residual shear samples, sizes are: .20 = 2.0"; .242 = 2.42"; .25 = 2.5"; .40 = 4.0"; .50 = 50mm; .60 = 60mm, and .100 = 100mm. **NOTE:** use "S" for square and "D" for round samples.

**Installation and Spare Parts Kit HM-4168:** Direct Shear Installation and Spare Parts Kit Installation and spare parts kit provides tubing, fasteners and tools to complete an installation of pneumatic direct shear equipment.

# ELITE SERIES Load Frames



## Elite Series Load Frames

ASTM D1883, D2850, D2166, D4767 and D1559; AASHTO T193, T296, T297, T208, T245 and T246; BS 1377: Part 4, BS 1377 Part 7, BS 1377 Part 8, BS 598 Part 107

Humboldt's Elite Series Load Frames provide the materials testing lab with a choice of three, highly-versatile and precision-built loading systems covering a range of testing applications. The HM-5030 is the workhorse of the group, capable of handling any testing need up to 50kN or 11,000 lbf. The HM-5020 is a machine designed specifically for triaxial

testing and other testing requirements up to 15kN or 3,000 lbf. and, the HM-5040, is a heavy-duty machine capable of handling testing requirements up to 100kN or 22,000 lbf.

These machines provide four (4) integral and independent data acquisition channels, which can be utilized in stand-alone configurations or accessed through a LAN-networked computer using Humboldt's Next Software.

Elite Series load frames are built with durable, high-quality components and feature the use of a stepper motor, precision gears and gear box to ensure smooth and reliable operation, as well as precise results.

In stand-alone mode, these load frames provide a 7" (178mm) touch-screen controller. These new waterproof, touch screens provide colorful, at-a-glance monitoring of testing functions without the use of a computer. Operators can see all the data in several formats at the machine while the test is running. Data can then be downloaded later to a computer in the lab, in the next room or at a different location, while also providing report generation capabilities from within Humboldt's NEXT software or our enhanced test-specific modules.

## NOTES

Elite Series load frames are sold as load frames only though shown here with typical triaxial setups



**HM-5020** TRIAXIAL LOADER

Load capacity	3000 lbf (15kN)
Speed Range Testing:	0.00001 – 2.00000 in/min (0.00001 – 50.80000 mm/min)
Fast Approach:	2.1 in/min (55.0 mm/min)
Data channels	4
Platen Size / Travel	10" (254mm) / 4" (100mm)
Data storage	1000 tests and up to 3000 readings per test
Clearance, vertical	27" (686mm)
Clearance, horiz.	11" (286mm)
Voltage	110/220V 50/60Hz. 5.0 amps

A small-footprint, triaxial-specific load frame that provides the versatility, precision and durability found throughout Humboldt's Elite Series load frames.

The HM-5020 Triaxial Loader has been specifically designed to handle triaxial testing applications, including: UU, CU and CD triaxial and UC. From educational institutions and consulting firms to high-volume commercial labs and construction projects, the Triaxial Loader can handle any application with ease. Its heavy-duty design and precise stepper-motor control provide a stable platform for years of reliable service allowing the HM-5020 to perform any tests required up to its load capacity of 3000 lbf (15kN).

Like all Elite Series load frames, the HM-5020 is built around Humboldt's integral, 4-channel data logger with touch-screen control, which allows the load frame to be used as a standalone device capable of full test control and data logging. It can also be controlled by a networked computer at any location with access to the network.

Triaxial Loader, 110/220V 50/60 Hz **HM-5020.3F**  
Shipping wt. 300 lb (54kg)

**HM-5030** MASTER LOADER

Load capacity	11000 lbf (50kN)
Speed Range Testing:	0.00001 – 2.00000 in/min (0.00001 – 50.80000 mm/min)
Fast Approach:	3.0 in/min (75.0 mm/min)
Data channels	4
Platen Size / Travel	10" (254mm) / 4" (100mm)
Data storage	1000 tests and up to 3000 readings per test
Clearance, vertical	40" (1000mm)
Clearance, horiz.	15" (380mm)
Voltage	110/220V 50/60Hz. 5.0 amps

Designed for applications requiring multi-purpose loading systems, such as road construction projects in either mobile or fixed labs, educational institutions and consulting firms, the HM-5030 Master Loader is ideal for just about any application from road construction to high-volume commercial and educational laboratories.

While the HM-5030 has been specifically designed for soil testing labs conducting multiple testing operations including: UU, CU and CD triaxial, UC, CBR and LBR, it is also perfect for running Marshall, Hveem, TSR and SCB asphalt tests as well. Its heavy-duty design and precise stepper-motor control provide a stable platform for years of reliable service allowing the HM-5030 to perform any tests required up to its load capacity of 11000 lbf (50kN).

Like all Elite Series load frames, the HM-5030 is built around Humboldt's integral, 4-channel data logger with touch-screen control, which allows the load frame to be used as a standalone device capable of full test control and data logging. It can also be controlled by a networked computer at any location with access to the network.

Master Loader, 110/220V 50/60 Hz **HM-5030.3F**  
Shipping wt. 300 lb (136kg)

**HM-5040** GRAND LOADER

Load capacity	22000 lbf (100kN)
Speed Range Testing:	0.00001 – 0.49999 in/min (0.00001 – 12.50000 mm/min)
Fast Approach:	0.5 in/min (12.5 mm/min)
Data channels	4
Platen Size / Travel	10" (254mm) / 4" (100mm)
Data storage	1000 tests and up to 3000 readings per test
Clearance, vertical	44" (1100mm)
Clearance, horiz.	21" (540mm)
Voltage	110/220V 50/60Hz. 5.0 amps

The HM-5040 Grand Loader is ideal for just about any application from road construction to high-volume commercial and educational laboratories, which require higher pressure loading capacities up to 22000 lbf (100kN), such as those involving larger sized samples and samples comprised of rock and rock/soil mixtures. It's wider stance and large vertical and horizontal clearances allows it to accommodate much large sample cells.

Its heavy-duty design and precise stepper-motor control provide a stable platform for years of reliable service allowing the HM-5040 to perform any tests required up to its load capacity of 22000 lbf (100kN).

Like all Elite Series load frames, the HM-5040 is built around Humboldt's integral, 4-channel data logger with touch-screen control, which allows the load frame to be used as a standalone device capable of full test control and data logging. It can also be controlled by a networked computer HM-5040 includes a storage base with casters.

Grand Loader, 110/220V 50/60 Hz **HM-5040.3F**  
Shipping wt. 725 lb (329kg)





# ELITE SERIES Load Frames



## Choose: Stand-Alone or Computer Control

### Stand-Alone Control

Humboldt's touch-screen controller provides you with full, graphical monitoring of all testing functions in a stand-alone application, while maintaining full computer control when desired.

Now you can have full, finger-tip control and monitoring of all testing functions with Humboldt's touch-screen controller, found on Humboldt's Elite Series Load Frames. This seven-inch, waterproof screen provides at-a-glance monitoring of testing functions, in a real-time graphical display, without the use of a computer, building upon Humboldt's dedication to modular, stand-alone data acquisition.

Now, in a stand-alone application, you will be able to run tests and display results while viewing tabulation, basic x-y graphs and instrument readings in real-time during the test, using user-defined, basic data acquisition. Test data is stored in the device and can be downloaded to a USB drive via the machine's FRONT USB port or the data can be transferred to a computer via the LAN port.

A second USB port located on the back of the machine can also be used to power a wireless access point, which can provide a wireless hook-up with a computer, if no LAN is available.

Touch-Screen Controller provides:

- 4-channel data acquisition
- Hi-res, 7", waterproof, touch-screen provides total control and real-time graphical display of tests
- Machine/Test control and data acquisition via touch-screen
- Control all channels at the same time
- Calibration of channels to load cell and transducer
- Real-time graphical chart and numerical display of tests via touch-screen display
- Effective sampling rate of 50 readings per second
- Stores up to 1000 tests with 3000 points per test
- 2 USB ports. One in front for data transfer and the rear port is for powering a wireless access point.

### Computer Control

Humboldt's Next software is included with the all Elite Series Load Frames. This software provides robust machine control, data acquisition and report generation for those using a computer to control testing operations.

In addition, operators have the ability to view and control testing operations from a PC in the lab, in the next room or at a different location, while also providing report generating capabilities using NEXT software and the test-specific software modules.

So, whether you are controlling a single load frame, controlling multiple machines or even a complete geotechnical lab, Humboldt's NEXT software, in conjunction with Humboldt's Elite Series Load Frames provide a complete solution for acquisition, recording and presentation of testing data in data tabulation and graphic chart formats.

- Machine control, and data acquisition via networked computer
- Provides the ability to use Next Software's, advanced test-specific modules
- Real-time graphical chart and numerical display of tests via computer display
- Effective sampling rate of 50 readings per second
- Stores unlimited tests with up to 3000 points per test.
- Up to 255 individual tests can be run simultaneously from a single PC
- Provides advanced graphing capabilities
- Provides full-unit customization
- Reports can also be exported to Excel or a CSV file, if desired, and, we can provide custom integration/export solutions for LIMS, EQuIS, gINT, etc.

# Controller Specifications

Specifications for the touch-screen controller, instrumentation and data acquisition used with Humboldt Elite series load frames

## Typical Test Setups with HM-5030

Controller Specifications:	
Display (Resistive Touch)	7" (178mm) VGA (480 x 800)
Real-time test data	Graphic and tabulation
Processor	Dual 32-bit ARM
RAM	64MB
Memory, non-volatile	4GB
Analog to digital converter	24 bit
Data acquisition	4 Channels
Logging speed	up to 50 readings per second
Multi-test storage	1000
Points per test	3000
USB port (front)	export data, import/export calibration data, WiFi
USB port (back)	provides external power for wireless access point
Ethernet connection	for network connectivity
Emergency stop	Large button
24-bit differential analog to digital converter	4
Ambient temperature sensor	1
Limit switches	2
Firmware Update	Ethernet or flash drive



CBR/LBR



Unconfined Compression



Consolidated Drained and Undrained



Unconsolidated Undrained

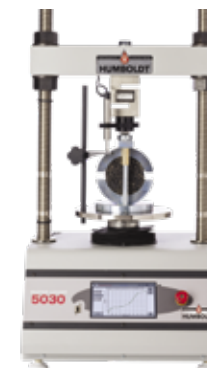

Marshall



Semi-Circular Bending



HM-2850.3F

HM-2850 load frame shown with optional components for conducting CU Triaxial tests.

Specifications	
Load capacity	11000 lbf (50kN)
Speed range	.00001 - 2.00000 in/min. .00001 - 50.80000 mm/min.
Platen Size / Travel	8" (203mm) / 4" (100mm)
Clearance, vertical	40" (1000mm)
Clearance, horiz.	11" (279mm)
Dimensions (l x w x h).	17 x 22 x 51 inch (432 x 559 x 1295mm)
Voltage	110/220V 50/60Hz. 5.0 amps

**Multi-Speed Load Frame**

ASTM: D1883, D2850, D2166, D4767, and D1559; AASHTO: T193, T296, T297, T208, T245, and T246; BS 1377: Part 4: 1990, BS 1377: Part 7: 1990, BS 1377: Part 8: 1990, BS 598: Part 107

The HM-2850 Multi-speed Load Frame is designed for those who want a high-quality, but simple, multi-purpose load frame without built-in data acquisition capabilities. The HM-2850 is ideal for applications where the operator is either not concerned with data acquisition; or, already has or is planning to construct their own data acquisition system. With its large 7" color, touchscreen, the HM-2850 provides the operator with the ability to precisely select any speed with four decimal accuracy within the machine's speed range.

The HM-2850 features a quiet, direct drive stepper motor that provides a range of loading speeds from 0.00001 to 2.00000 in/min. This speed range is more than adequate for the majority of standard soil tests. The HM-2850 also incorporates a separate, dedicated control to accommodate 2.00 in/min. for use in Marshall and TSR Testing, as well as a rapid travel speed of 2.25 in/min for moving the platen into position quickly. Speeds are controlled through the use of edit keys and the digital display.

Multi-Speed Load Frame, 110/220V 50/60 Hz HM-2850.3F  
Shipping wt. 300 lb (136kg)

**Features include:**

- 8" platen provides roomy, stable base for test equipment
- User selectable unit change from touchscreen between U.S. Standard and Metric units.

**Multi-Speed Load Frame— HM-2850.3F**

Includes:  
3/4-16 HHG531/2  
WF04—Washer

**CU/UU Triaxial Setup with HM-2850**

Components	Item
<b>Load</b>	
50kN (11240 lbf) capacity	HM-2850.3F
<b>Strain</b>	
Load ring 2,200 lbf (10 kN)	H-4454.020
Dial gauge 2.0" travel, 0.001" divisions)	H-4463
Pore pressure transducer	HM-4170
Ball seat adapter	HM-200387
Single channel readout (choose)	HM-2350 HM-2350.4F
NEXT software basic, user defined	included
<b>Pressure</b>	
Pressure distribution panel for CU triaxial (choose)	HM-4150.3F HM-4150M.3F
Pressure distribution panel for UU triaxial (choose)	HM-4140.3F HM-4140M.3F
De-airing system	HM-4187A.3F
Vacuum pump (choose)	H-1763A H-1763A.4F
<b>Triaxial Cell (choose 1 below)</b>	
3" / 75mm dia. capacity	HM-4199B
4" / 100mm dia. capacity	HM-4199B-4
Top Cap/ Base Pedestal Set (specify specimen size)	HM-4199.XX

**Unconfined Compression Setup with HM-2850**

Components	
<b>Load</b>	
50kN (11240 lbf) capacity	HM-2850.3F
Upper unconfined platen	HM-2002
Displacement Contact Assembly	HM-3000.10.5
Load ring 500 lbf (2.5 kN)	H-4454.005
Dial gauge 2.0" travel 0.001" divisions	H-4463

**Typical Soil Cement Setup**

Components	
<b>Load</b>	
50kN (11240 lbf) capacity	HM-2850.3F
Upper swivel platen	HM-2003E
<b>Strain</b>	
Load ring 5,000 lbf (25 kN)	H-4454.050





HM-4199B



HM-4199B-6



HM-5199B-4



HM-4199.28

**Standard Triaxial Cells**

Triaxial Cells are available for use with sample sizes from 1.4" (35mm) to 6" (150mm). The clear acrylic chamber has a working pressure of 150 psi (1,000 kPa) and is tested to 250 psi (1,700 kPa). The design features a solid base, which provides an extremely stable test platform making it faster and easier to center the cell on the load frame platen— reducing setup times. HM-4199B cells provide easy access to the test chamber by utilizing a one-piece, chamber unit that is quickly removed through the removal of three easy-turn knobs. These cells also have an integral de-airing block for the pore pressure transducer built into the side. The cells have five no-volume-change valves aligned on one side for maximum convenience. Two valves handle top drainage, two valves handle bottom drainage, and one valve handles filling and drainage, as well as providing confining pressure to the cell. The removable base pedestal accommodates various

sample diameters. Top caps and base pedestals are available in a choice of black-anodized aluminum or stainless steel in various sizes (see chart below). Other sizes are available. The cell top and base are precision machined from 6061 T6 aluminum, black anodized for a durable finish. A .625" hardened stainless steel piston runs inside a linear bearing to reduce friction. Choice of brass or stainless steel valve fittings is available (stainless steel for use with hazardous materials). When ordering, specify top cap and base pedestal for desired sample size, see charts below. Order porous stones separately, see page 144.

**Double-wall Triaxial Cell w/ Submersible Load Cell**  
This Double-wall Triaxial Cell can handle samples up to 4" (100mm) and includes a 2000lb (10kN) Submersible Load Cell (HM-2300.020S) Double-wall Triaxial Cells are typically used when testing unsaturated soil samples.

Double-Wall Triaxial Cell, 4" (100mm) **HM-5199B-4**  
28 lb (13kg)

Size	Top Cap/ Pedestal Set	
	Aluminum	Stainless Steel
35mm	HM-4199.35	HM-4199.35
1.4"	HM-4199.14	HM-4199.14
38mm	HM-4199.38	HM-4199.38
1.5"	HM-4199.15	HM-4199.15
50mm	HM-4199.50	HM-4199.50
2.0"	HM-4199.20	HM-4199.20
70mm	HM-4199.70	HM-4199.70
2.8"	HM-4199.28	HM-4199.28
100mm	HM-4199.100	HM-4199.100
4.0"	HM-4199.40	HM-4199.40
150mm	HM-4199.150	HM-4199.150
6"	HM-4199.60	HM-4199.60

Size	Top Cap	
	Aluminum	Stainless Steel
35mm	HM-4199.35T	HM-4199.35SST
1.4"	HM-4199.14T	HM-4199.14SST
38mm	HM-4199.38T	HM-4199.38SST
1.5"	HM-4199.15T	HM-4199.15SST
50mm	HM-4199.50T	HM-4199.50SST
2.0"	HM-4199.20T	HM-4199.20SST
70mm	HM-4199.70T	HM-4199.70SST
2.8"	HM-4199.28T	HM-4199.28SST
100mm	HM-4199.100T	HM-4199.100SST
4.0"	HM-4199.40T	HM-4199.40SST
150mm	HM-4199.150T	HM-4199.150SST
6"	HM-4199.60T	HM-4199.60

**NOTE:** Cell sizes 35mm, 1.4", 38mm and 1.5" include HM-4199B.20 piston extension.

**NOTES**  
When ordering cells, specify top cap and base pedestal for desired sample size. Order porous stones separately, see page 144.

Size	Pedestal	
	Aluminum	Stainless Steel
35mm	HM-4199.35B	HM-4199.35SSB
1.4"	HM-4199.14B	HM-4199.14SSB
38mm	HM-4199.38B	HM-4199.38SSB
1.5"	HM-4199.15B	HM-4199.15SSB
50mm	HM-4199.50B	HM-4199.50SSB
2.0"	HM-4199.20B	HM-4199.20SSB
70mm	HM-4199.70B	HM-4199.70SSB
2.8"	HM-4199.28B	HM-4199.28SSB
100mm	HM-4199.100B	HM-4199.100SSB
4.0"	HM-4199.40B	HM-4199.40SSB
150mm	HM-4199.150B	HM-4199.150SSB
6"	HM-4199.60B	HM-4199.60SSB



HM-4155



HM-4154



HM-4165.3F



HM-4164.3F

**Automated Control Panel**

ASTM: D2850, D2166, D4767, and D1559; AASHTO: T193, T296, T297, T208; BS 1377: Part 4: 1990, BS 1377: Part 7: 1990, BS 1377: Part 8: 1990

Used in conjunction with the HM-2450A.3F pressure controller, Humboldt automated control panels provide an accurate and easy-to-operate solution for providing the controls necessary for distributing compressed air, water, de-aired water and vacuum within an air/water bladder-type triaxial testing system. The use of these control panels and the HM-2450A.3F pressure controller allows changes in cell and back pressures required for sample saturation to be done automatically without the need for an operator. This feature reduces the need for continual monitoring of the sample saturation process during a triaxial test.

Specifications			
Pressure gauge	psi	BAR	Mpa
Max. input pressure	200	14	1.4
Max. output pressure	150	10	1
Pressure resolution	0.1	0.01	0.001
Display	LCD		
HM-4164 dimensions (L x W x H)	8 x 8 x 37.5" (203 x 203 x 952mm)		
HM-4165 dimensions (L x W x H)	8 x 19.5 x 37.5" (203 x 495 x 952)		

Humboldt auto control panels feature an analog input pressure gauge and controller, an air/water filter for the input pressure and de-aired water tank input, as well as quick-disconnects for quickly connecting bladders, the pressure controller and triaxial cells.

The HM-4154 provides connections for one triaxial cell, while the HM-4155 provides connections for up to three triaxial cells. For each triaxial cell, one bladder is required for generating the cell pressure and a second bladder is required for back pressure.

Automated Panel, 1 Cell	<b>HM-4154</b>
Shipping wt. 100 lb (45.3kg)	
Automated Panel, 3 Cell	<b>HM-4155</b>
Shipping wt. 80lb (36.2kg)	

**Manual Control Panel**

ASTM: D2850, D2166, D4767, and D1559; AASHTO: T193, T296, T297, T208; BS 1377: Part 4: 1990, BS 1377: Part 7: 1990, BS 1377: Part 8: 1990

For those operations that do not require automated control, Humboldt's HM-4164 and HM-4165 manual control panels provide an accurate and easy-to-operate solution for controlling compressed air, water, de-aired water and vacuum within an air/water bladder-type triaxial testing system.

The use of these control panels provides the necessary control for making changes in cell and back pressures required for sample saturation to be done from a central location on the panel. The operator has complete control of system pressure during the triaxial test with three independently-controlled pressure regulators. These control panels have a bias pressure regulator feature, which allows simultaneous control of confining and back pressures, while maintaining a constant differential pressure

Humboldt manual control panels feature an analog input pressure gauge and controller, an air/water filter for the input pressure and de-aired water tank input, a digital pressure readout for each set of cell functions, as well as quick-disconnects for quickly connecting bladders, the pressure controller and triaxial cells.

Specifications			
Pressure gauge	psi	BAR	Mpa
Max. input pressure	200	14	1.4
Max. output pressure	150	10	1
Pressure resolution	0.1	0.01	0.001
HM-4164 dimensions (L x W x H)	8 x 8 x 37.5" (203 x 203 x 952mm)		
HM-4165 dimensions (L x W x H)	8 x 19.5 x 37.5" (203 x 495 x 952)		

The HM-4164 provides connections for one triaxial cell, while the HM-4165 provides connections for up to three triaxial cells. For each triaxial cell, one bladder is required for generating the cell pressure and a second bladder is required for back pressure .

Manual Panel, psi, 1 Cell, 120/220V 50/60Hz	<b>HM-4164.3F</b>
Shipping wt. 100 lb (45.3kg)	
Manual Panel, kPa, 1 Cell, 120/220V 50/60Hz	<b>HM-4164M.3F</b>
Shipping wt. 100 lb (45.3kg)	
Manual Panel, psi, 3 Cell, 120/220V 50/60Hz	<b>HM-4165.3F</b>
Shipping wt. 76 lb (34.7kg)	
Manual Panel kPa, 3 Cell, 120/220V 50/60Hz	<b>HM-4165M.3F</b>
Shipping wt. 100 lb (45.3kg)	





HM-4140.3F

HM-4150.3F

HM-4160.3F

HM-4150A

HM-4160A

**Humboldt FlexPanels**

ASTM: D1559, D2850, D2166, D4767, and D5084; AASHTO: T193, T296, T297, T208; BS 1377: Part 4: 1990, BS 1377: Part 6, BS 1377: Part 7: 1990, BS 1377: Part 8: 1990

Humboldt FlexPanels provide an accurate and easy-to-operate solution for controlling compressed air, water, de-aired water and vacuum without the need for air/water bladder interfaces to produce the pressures necessary for triaxial testing. FlexPanels utilize a set of three burettes to control cell, top cap and base pedestal pressures.

This extremely versatile pressure system controls the pressure, water, de-airing tank and vacuum from a single panel. The three burettes allow for the control of the cell pressure and the back pressure

for each cell. They can monitor volume change in the sample and can be used to measure the flow of water through the sample for permeability testing. FlexPanels can manually measure volume change or permeability in a triaxial test sample without the use of a volume change apparatus, a distinct benefit when compared to air/water bladder systems. See page 92-93 for more information and specifications for Humboldt's FlexPanels.

Control Panel (psi), 120/220V 50/60Hz **HM-4140.3F**  
Shipping wt. 35 lb (16kg)

Control Panel (kPa), 120/220V 50/60Hz **HM-4140M.3F**  
Shipping wt. 50 lb (22.6kg)

Control Panel, 1-Cell (psi), 120/220V 50/60Hz **HM-4150.3F**  
Shipping wt. 98 lb (44.5kg)

Control Panel, 1-Cell (kPa), 120/220V 50/60Hz **HM-4150M.3F**  
Shipping wt. 98 lb (44.5kg)

Control Panel, 2-Cell (kPa), 120/220V 50/60Hz **HM-4160.3F**  
Shipping wt. 175 lb (79.3kg)

Control Panel, 2-Cell (kPa), 120/220V 50/60Hz **HM-4160M.3F**  
Shipping wt. 125 lb (56kg)

Auxiliary Panel, 1-Cell **HM-4150A**  
Shipping wt. 77 lb (34.9kg)

Auxiliary Panel, 2-Cell **HM-4160A**  
Shipping wt. 275 lb (124.7kg)

	HM-4140.3F	HM-4140M.3F	HM-4150.3F	HM-4150M.3F	HM-4160.3F	HM-4160M.3F	HM-4150A	HM-4160A
Pressure/Resolution	2-150 psi (0.1 psi)	14-1000 kPa (1 kPa)	2-150 psi (0.1 psi)	14-1000 kPa (1 kPa)	2-150 psi (0.1 psi)	14-1000 kPa (1 kPa)	Not Applicable	
Vacuum	0-14.7 psi or 30 Hg	(0-100kPa) or 30 Hg	0-14.7 psi or 30 Hg	(0-100kPa) or 30 Hg	0-14.7 psi or 30 Hg	(0-100kPa) or 30 Hg		
Inner Burette								
Cell	Not Applicable				50cc x 0.1 cc (ml) area = 0.305cm <sup>2</sup>			
Top	Not Applicable				10cc x 0.02 cc (ml) area = 0.305cm <sup>2</sup>			
Base	Not Applicable				10cc x 0.02 cc (ml) area = 0.305cm <sup>2</sup>			
Outer Burette								
Cell	Not Applicable				400 cc (ml)			
Top	Not Applicable				460 cc (ml)			
Base	Not Applicable				460 cc (ml)			
Voltage	110/220VAC 50/60Hz						Not Applicable	
Power	6 watts							
Operating Temperature	14 to 158°F (-10 to 70°C)							
Dimensions	8 x 8 x 37.5" (203 x 203 x 952mm)		8 x 25.5 x 37.5" (203 x 648 x 952mm)		8 x 43.5 x 37.5" (203 x 1105 x 952mm)		8 x 19.5 x 37.5" (203 x 495 x 952)	8 x 37.5 x 37.5" (203 x 952 x 952)
Shipping Weight	35lb (16kg)		98lb (44.4kg)		175lb (79.3kg)		77lb (34.9kg)	275lb (124.7kg)

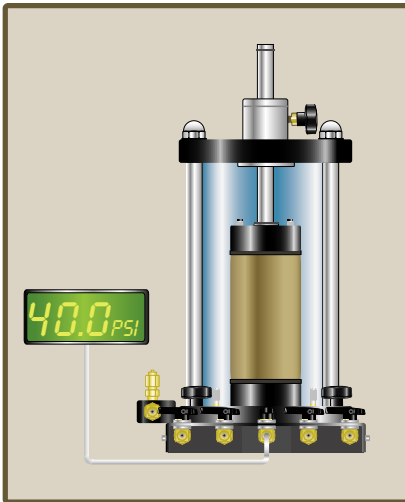

UU-Triaxial Test  
Typical Cell Setup

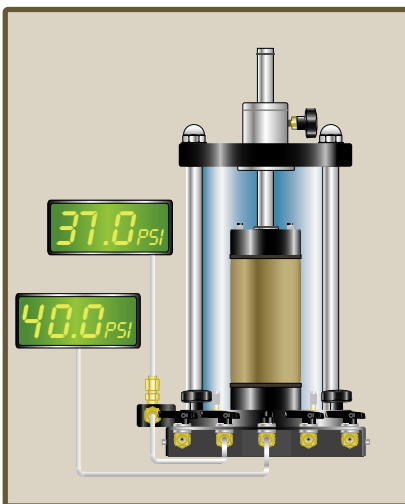

CU-Triaxial Test  
Typical Cell Setup

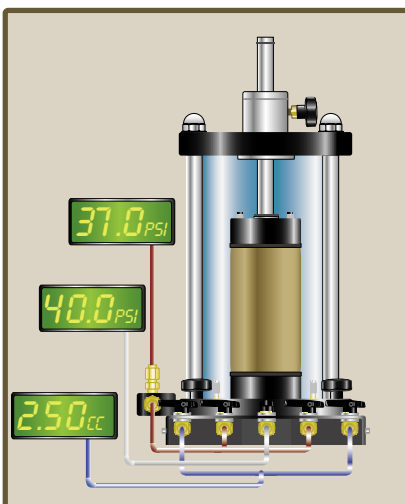

CD-Triaxial Test  
Typical Cell Setup

### Humboldt Triaxial Testing Systems

Humboldt provides an extensive line of triaxial testing equipment solutions for today's soil labs.

Presented below and on the following pages are three triaxial systems based around our HM-5030 and HM-5020 load frames, our NEXT software with triaxial-specific software modules and three different pressure control solutions.

### Automated Pressure Control Triaxial System

Designed for those who want the ultimate in control of their triaxial testing, Humboldt's automated pressure control triaxial system is a computer-controlled system specifically designed for soil testing laboratories conducting UU, CU and CD Triaxial tests, as well as unconfined compression. It is perfect for large, high-volume labs, as well as those who want to utilize technology to increase staff efficiencies and testing accuracy. This system provides complete control of the testing process including data acquisition.

Available in one or three-cell configurations, our automated control panels can handle your testing needs in stride. And, if you want to increase the number of simultaneous tests you can run, Humboldt's NEXT software can easily handle a multitude of tests. All you need to do is add cells and the other appropriate equipment to handle your needs.

Humboldt's automated pressure control triaxial system is built around the HM-5240.3F Stand-alone pressure controller. The HM-5240.3F is a fully-automated pneumatic pressure controller, which is highly accurate up to 150psi (1000kpa) in pressure and 100cc (100ml) in volume. It is designed specifically for geotechnical laboratory triaxial testing (UU, CU and CD) and provides control and monitoring of cell pressure, back pressure, pore water measurement and volume change when used with our Elite Series load frames.

The HM-5240 provides four (4) integral and independent data acquisition channels, which can be utilized in stand-alone configuration or accessed through a LAN-networked computer using Humboldt's NEXT software. The unit is built with durable high-quality components and features the use of two electronic regulators to ensure smooth and reliable operation of pressures, as well as precise results.

In stand-alone mode, this pressure controller provides a 7" (178mm) touch-screen controller. This new waterproof, touch screen provides colorful, at-a-glance monitoring of testing functions without the use of a computer. Operator could see all the data in several formats at the controller while the test is running. Then can be viewed simultaneously or downloaded later to a computer in the lab, in the next room or at a different location, while also providing report generation capabilities from within Humboldt's NEXT software or our enhanced test-specific modules. The system can also be configured for use with our triaxial-specific load frame, the HM-2900. While Humboldt's automated pressure control triaxial system has been designed to work as a complete system, its make-up provides for the ultimate in versatility and expanded possibilities.

See pages 132-133 for a complete component list for the automated pressure control triaxial system



Automated Pressure Control Triaxial System Components

**Manual Pressure Control Triaxial System**

Humboldt's manual pressure control triaxial system provides a manually-controlled alternative to our automated system. The manual system eliminates the HM-5240.3F pressure controller from the system and replaces its function with a control panel that allows for manual control of the confining and back pressures. The HM-2315 Volume Change Apparatus, which measures the volume change of a soil sample by monitoring the flow of water through the chamber of the unit. The lower assembly contains changeover valves, which when used in conjunction with the upper assembly provides limitless capacity. It is accurate to better than  $\pm 0.05$  ml and is easily de-aired in seconds

Like the automated system, our manually-controlled system can run UU, CU and CD triaxial tests, as well as unconfined compression. Manual control panels are available in one or three-cell configurations and can be used in multiple configurations. All you need to do is add cells and the other appropriate equipment to handle your needs.

Humboldt's manual pressure control triaxial system is built around our NEXT software and our enhanced test-specific modules, which monitors, controls and reports test data, and, the highly-regarded HM-5030 load frame with its built-in, 4-channel data acquisition controller for stress, strain, pore water pressure and volume change measurement. The system can also be configured for use with our triaxial-specific load frame, the HM-5020. While Humboldt's manual pressure control triaxial system has been designed to work as a complete system, its make-up provides for the ultimate in versatility and expanded possibilities.

See pages 134-135 for a complete component list for the Manual Pressure Control Triaxial System

**FlexPanel Pressure Control Triaxial System**

Humboldt's FlexPanel pressure control option eliminates the use of the air/water bladder interface concept of pressure control in lieu of its highly-accurate burette system. Humboldt FlexPanels provide an accurate and easy-to-operate solution for controlling compressed air, water, de-aired water and vacuum without the need for air/water bladder interfaces to produce the pressures necessary for triaxial testing. FlexPanels utilize a set of three burettes to control cell, top cap and base pedestal pressures.

This extremely versatile pressure system controls the pressure, water, de-airing tank and vacuum from a single panel. The three burettes allow for the control of the cell pressure and the back pressure for each cell. They can monitor volume change in the sample and can be used to measure the flow of water through the sample for permeability testing. This is a benefit to using FlexPanels over the air/water bladder system.

Like our other control systems you can run UU, CU and CD triaxial tests, as well as unconfined compression with FlexPanels. They are available in one or three-cell configurations and can be used in multiple configurations. All you need to do is add cells and the other appropriate equipment to handle your needs.

Humboldt's FlexPanel pressure control system also uses our NEXT software and our enhanced test-specific modules, which monitors, controls and reports test data, and, the highly-regarded HM-5030 load frame with its built-in, 4-channel data acquisition controller for stress, strain, pore water pressure and volume change measurement. The system can also be configured for use with our triaxial-specific load frame, the HM-5020. See pages 136-137 for a complete component list for the FlexPanel Pressure Control Triaxial System.



Manual Pressure Control Triaxial System Components



FlexPanel Pressure Control Triaxial System Components

Triaxial Setups



# Automatic Pressure Control

## Component List for 1 and 3-Cell Triaxial System with Automatic Pressure Control

Automatic Pressure Control System, 1-Cell Setup

Components		
<b>Load Frame (choose 1 below)</b>		
50kN (11240 lbf) capacity	HM-5030.3F	1
15kN (3372 lbf) capacity	HM-5020.3F	1
<b>Load/Strain</b>		
Load Cell	HM-2300.020	1
Strain Transducer (LSCT)	HM-2310.20	1
Ball Seat Adapter	HM-200387	1
Strain Transducer Bracket	HM-4178BRT	1
UU Triaxial Software Module	HM-5002SW	1
CU Triaxial Software Module	HM-5003SW	1
CD Triaxial Software Module	HM-5006SW	1
<b>Pressure/Volume Change</b>		
Pressure Distribution Panel	HM-4154	1
Air/Water Bladder	HM-4151A	2
Pressure/Volume Controller	HM-5240.3F	1
De-airing System	HM-4187A.3F	1
Vacuum Pump	H-1763A or H-1763A.4F	1
Silent Air Compressor	HM-4220 or HM.4220.4F	1
<b>Triaxial Cell (choose 1 below)</b>		
3" / 75mm dia. capacity	HM-4199B	1
4" / 100mm dia. capacity	HM-4199B-4	1
Top Cap/ Base Pedestal Set (specify specimen size)	HM-4199.XX	1
Installation Kit	HM-4167	1

Automatic Pressure Control System, 3-Cell Setup

Components		
<b>Load Frame (choose 1 below)</b>		
50kN(11240 lbf) capacity	HM-5030.3F	1
15kN (3372 lbf) capacity	HM-5020.3F	1
<b>Load/Strain</b>		
Load Cell	HM-2300.020	1
Strain Transducer (LSCT)	HM-2310.20	1
Ball Seat Adapter	HM-200387	1
Strain Transducer Bracket	HM-4178BRT	1
UU Triaxial Software Module	HM-5002SW	1
CU Triaxial Software Module	HM-5003SW	1
CD Triaxial Software Module	HM-5006SW	1
<b>Pressure/Volume Change</b>		
Pressure Distribution Panel	HM-4155	1
Air/Water Bladder	HM-4151A	6
Pressure/Volume Controller	HM-5240.3F	3
De-airing System	HM-4187A.3F	1
Vacuum Pump	H-1763A or H-1763A.4F	1
Silent Air Compressor	HM-4220 or HM.4220.4F	1
<b>Triaxial Cell (choose 1 below)</b>		
3" / 75mm dia. capacity	HM-4199B	3
4" / 100mm dia. capacity	HM-4199B-4	3
Top Cap/ Base Pedestal Set (specify specimen size)	HM-4199.XX	3
Installation Kit	HM-4167	1

### Standard Triaxial Sample Prep Accessories:

(See page 144 for a complete list and description. Items with .XX require a sample size)

Accessory	Item #	Required	Accessory	Item #	Required
Acrylic Base Disk	HM-4179.XX	2 or 6	2-Part Compaction Mold	HM-3818.XX	1
Membranes	HM-4180.XX	1	2-Part Vacuum Split Mold	HM-3827.XX	1
Membrane Stretcher	HM-4181.XX	1	Split Miter Box	HM-3847.XX	1
O-Rings (12-pack)	HM-4182.XX	1	Filter Paper (100-pack)	HM-4189.XX	1
O-Ring Placing Tool	HM-4183.XX	1	Filter Strips	HM-4189FS	1
Porous Stone	HM-4184.XX	2 or 6	High Vacuum Grease	HM-4198	1
Membrane Tester	HM-4185.XX	1			

### Triaxial Installation Kit

Kit designed to provide fittings, connectors, tubing and tools to complete a triaxial set up installation. See page 141 for kit contents and other individual set up items.



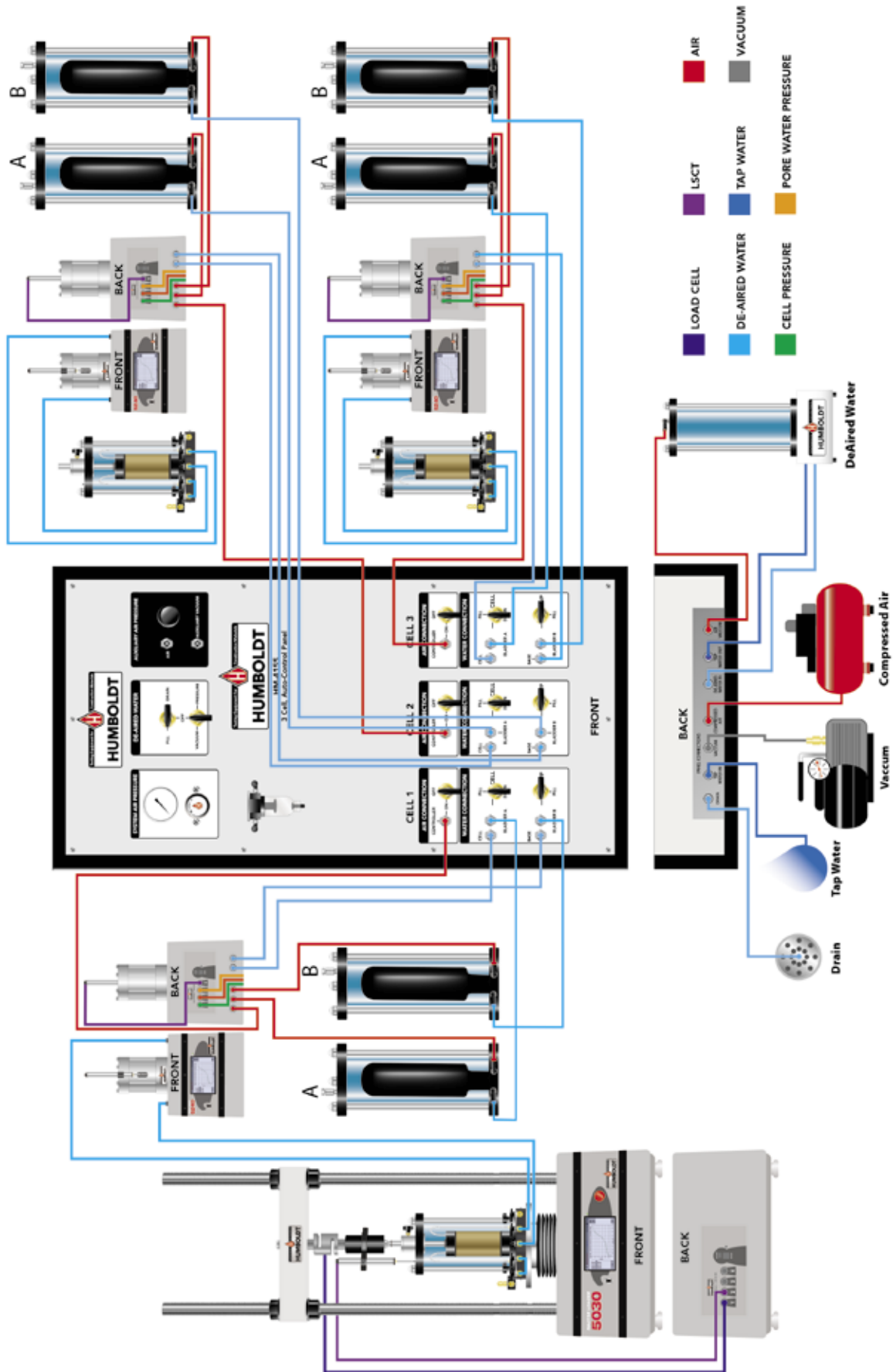

Automatic Pressure Control System, 3-Cell Setup

# Manual Pressure Control

## Component List for 1 and 3-Cell Triaxial System with Manual air/water bladder Pressure Control

Manual Pressure Control System, 1-Cell Setup

Components		
<b>Load Frame (choose 1 below)</b>		
50kN (11240 lbf) capacity	HM-5030.3F	1
15kN (3372 lbf) capacity	HM-5020.3F	1
<b>Load/Strain/Pore Pressure</b>		
Load Cell	HM-2300.020	1
Strain Transducer (LSCT)	HM-2310.20	1
Ball Seat Adapter	HM-200387	1
Strain Transducer Bracket	HM-4178BRT	1
UU Triaxial Software Module	HM-5002SW	1
CU Triaxial Software Module	HM-5003SW	1
CD Triaxial Software Module	HM-5006SW	1
<b>Pressure</b>		
Pressure Distribution Panel	HM-4164.3F	1
Air/Water Bladder	HM-4151A	2
De-airing System	HM-4187A.3F	1
Pore Pressure Transducer	HM-4170	1
Silent Air Compressor	HM-4220 or HM.4220.4F	1
Vacuum Pump	H-1763A or H-1763A.4F	1
<b>Volume Change</b>		
Volume Change Apparatus (Required for CU & CD Triaxial)	HM-2315	1
Strain Transducer, 1" (25mm)	HM-2310.10	1
LSCT/LVDT Mounting Bracket	HM-2310BR	1
<b>Triaxial Cell (choose 1 below)</b>		
3" / 75mm dia. capacity	HM-4199B	1
4" / 100mm dia. capacity	HM-4199B-4	1
Top Cap/ Base Pedestal Set (specify specimen size)	HM-4199.XX	1
Installation Kit	HM-4167	1

Manual Pressure Control System, 3-Cell Setup

Components		
<b>Load Frame (choose 1 below)</b>		
50kN (11240 lbf) capacity	HM-5030.3F	1
15kN (3372 lbf) capacity	HM-5020.3F	1
<b>Load/Strain/Pore Pressure</b>		
Load Cell	HM-2300.020	1
Strain Transducer (LSCT)	HM-2310.20	1
Ball Seat Adapter	HM-200387	1
Strain Transducer Bracket	HM-4178BRT	1
UU Triaxial Software Module	HM-5002SW	1
CU Triaxial Software Module	HM-5003SW	1
CD Triaxial Software Module	HM-5006SW	1
Humboldt Logger	HM-5320.3F	1
<b>Pressure</b>		
Pressure Distribution Panel	HM-4165.3F	1
Air/Water Bladder	HM-4151A	6
De-airing System	HM-4187A.3F	1
Pore Pressure Transducer	HM-4170	3
Silent Air Compressor	HM-4220 or HM.4220.4F	1
Vacuum Pump	H-1763A or H-1763A.4F	1
<b>Volume Change</b>		
Volume Change Apparatus (Required for CU & CD Triaxial)	HM-2315	3
Strain Transducer, 1" (25mm)	HM-2310.10	3
LSCT/LVDT Mounting Bracket	HM-2310BR	3
<b>Triaxial Cell (choose 1 below)</b>		
3" / 75mm dia. capacity	HM-4199B	3
4" / 100mm dia. capacity	HM-4199B-4	3
Top Cap/ Base Pedestal Set (specify specimen size)	HM-4199.XX	3
Installation Kit	HM-4167	1

### Standard Triaxial Sample Prep Accessories:

(See page 144 for a complete list and description. Items with .XX require a sample size)

Accessory	Item #	Required	Accessory	Item #	Required
Acrylic Base Disk	HM-4179.XX	2 or 6	2-Part Compaction Mold	HM-3818.XX	1
Membranes	HM-4180.XX	1	2-Part Vacuum Split Mold	HM-3827.XX	1
Membrane Stretcher	HM-4181.XX	1	Split Miter Box	HM-3847.XX	1
O-Rings (12-pack)	HM-4182.XX	1	Filter Paper (100-pack)	HM-4189.XX	1
O-Ring Placing Tool	HM-4183.XX	1	Filter Strips	HM-4189FS	1
Porous Stone	HM-4184.XX	2 or 6	High Vacuum Grease	HM-4198	1
Membrane Tester	HM-4185.XX	1			

### Triaxial Installation Kit

Kit designed to provide fittings, connectors, tubing and tools to complete a triaxial set up installation. See page 141 for kit contents and other individual set up items.



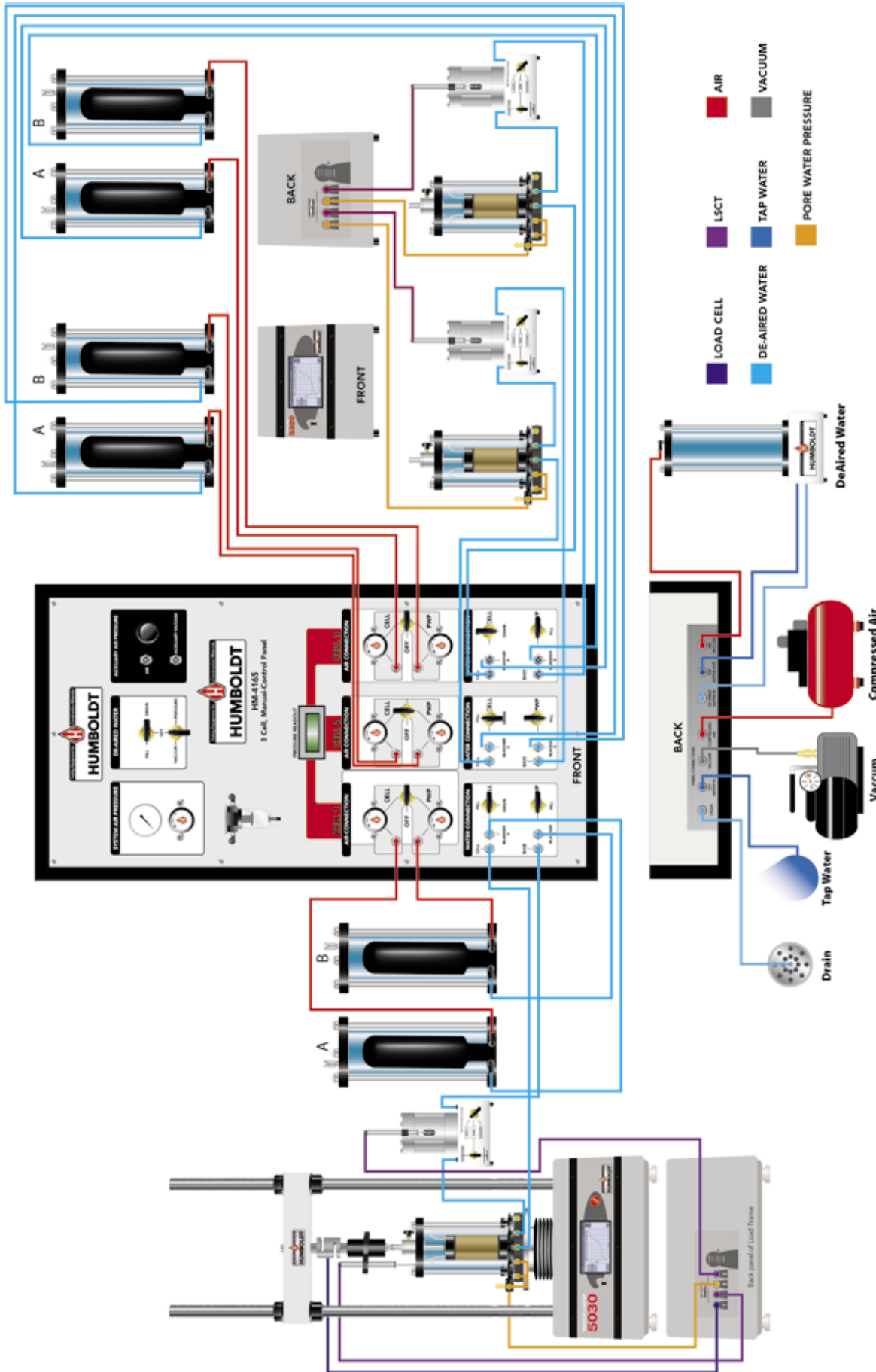

Manual Pressure Control System, 3-Cell Setup

# FlexPanels Pressure Control

## Component List for 1 and 3-Cell Triaxial/Permeability System with FlexPanel Pressure Control

FlexPanel Pressure Control System, 1-Cell Setup

Components		
<b>Load Frame (choose 1 below)</b>		
50kN (11240 lbf) capacity	HM-5030.3F	1
15kN (3372 lbf) capacity	HM-5020.3F	1
<b>Load/Strain/Pore Pressure</b>		
Load Cell	HM-2300.020	1
Strain Transducer (LSCT)	HM-2310.20	1
Pore Pressure Transducer	HM-4170	1
Ball Seat Adapter	HM-200387	1
Strain Transducer Bracket	HM-4178BRT	1
UU Triaxial Software Module	HM-5002SW	1
CU Triaxial Software Module	HM-5003SW	1
CD Triaxial Software Module	HM-5006SW	1
<b>Pressure</b>		
Pressure Distribution Panel	HM-4150.3F	1
De-airing System	HM-4187A.3F	1
Silent Air Compressor	HM-4220 or HM.4220.4F	1
Vacuum Pump	H-1763A or H-1763A.4F	1
<b>Volume Change</b>		
Volume Change Apparatus (Required for CD Triaxial)	HM-2315	1
Strain Transducer, 1" (25mm)	HM-2310.10	1
LSCT/LVDT Mounting Bracket	HM-2310BR	1
<b>Triaxial Cell (choose 1 below)</b>		
3" / 75mm dia. capacity	HM-4199B	1
4" / 100mm dia. capacity	HM-4199B-4	1
Top Cap/ Base Pedestal Set (specify specimen size)	HM-4199.XX	1
Installation Kit	HM-4167	1

FlexPanel Pressure Control System, 3-Cell Setup

Components		
<b>Load Frame (choose 1 below)</b>		
50kN (11240 lbf) capacity	HM-5030.3F	1
15kN (3372 lbf) capacity	HM-5020.3F	1
<b>Load/Strain/Pore Pressure</b>		
Load Cell	HM-2300.020	1
Strain Transducer (LSCT)	HM-2310.20	1
Pore Pressure Transducer	HM-4170	3
Ball Seat Adapter	HM-200387	1
Strain Transducer Bracket	HM-4178BRT	1
UU Triaxial Software Module	HM-5002SW	1
CU Triaxial Software Module	HM-5003SW	1
CD Triaxial Software Module	HM-5006SW	1
Humboldt Logger	HM-5320.3F	1
<b>Pressure</b>		
Pressure Distribution Panel	HM-4150.3F	1
Pressure Distribution Panel	HM-4160A	1
De-airing System	HM-4187A.3F	1
Silent Air Compressor	HM-4220 or HM.4220.4F	1
Vacuum Pump	H-1763A or H-1763A.4F	1
<b>Volume Change</b>		
Volume Change Apparatus (Required for CD Triaxial)	HM-2315	3
Strain Transducer, 1" (25mm)	HM-2310.10	3
LSCT/LVDT Mounting Bracket	HM-2310BR	3
<b>Triaxial Cell (choose 1 below)</b>		
3" / 75mm dia. capacity	HM-4199B	3
4" / 100mm dia. capacity	HM-4199B-4	3
Top Cap/ Base Pedestal Set (specify specimen size)	HM-4199.XX	3
Installation Kit	HM-4167	1

### Standard Triaxial Sample Prep Accessories:

(See page 144 for a complete list and description. Items with .XX require a sample size)

Accessory	Item #	Required	Accessory	Item #	Required
Acrylic Base Disk	HM-4179.XX	2 or 6	2-Part Compaction Mold	HM-3818.XX	1
Membranes	HM-4180.XX	1	2-Part Vacuum Split Mold	HM-3827.XX	1
Membrane Stretcher	HM-4181.XX	1	Split Miter Box	HM-3847.XX	1
O-Rings (12-pack)	HM-4182.XX	1	Filter Paper (100-pack)	HM-4189.XX	1
O-Ring Placing Tool	HM-4183.XX	1	Filter Strips	HM-4189FS	1
Porous Stone	HM-4184.XX	2 or 6	High Vacuum Grease	HM-4198	1
Membrane Tester	HM-4185.XX	1			

### Triaxial Installation Kit

Kit designed to provide fittings, connectors, tubing and tools to complete a triaxial set up installation. See page 141 for kit contents and other individual set up items.



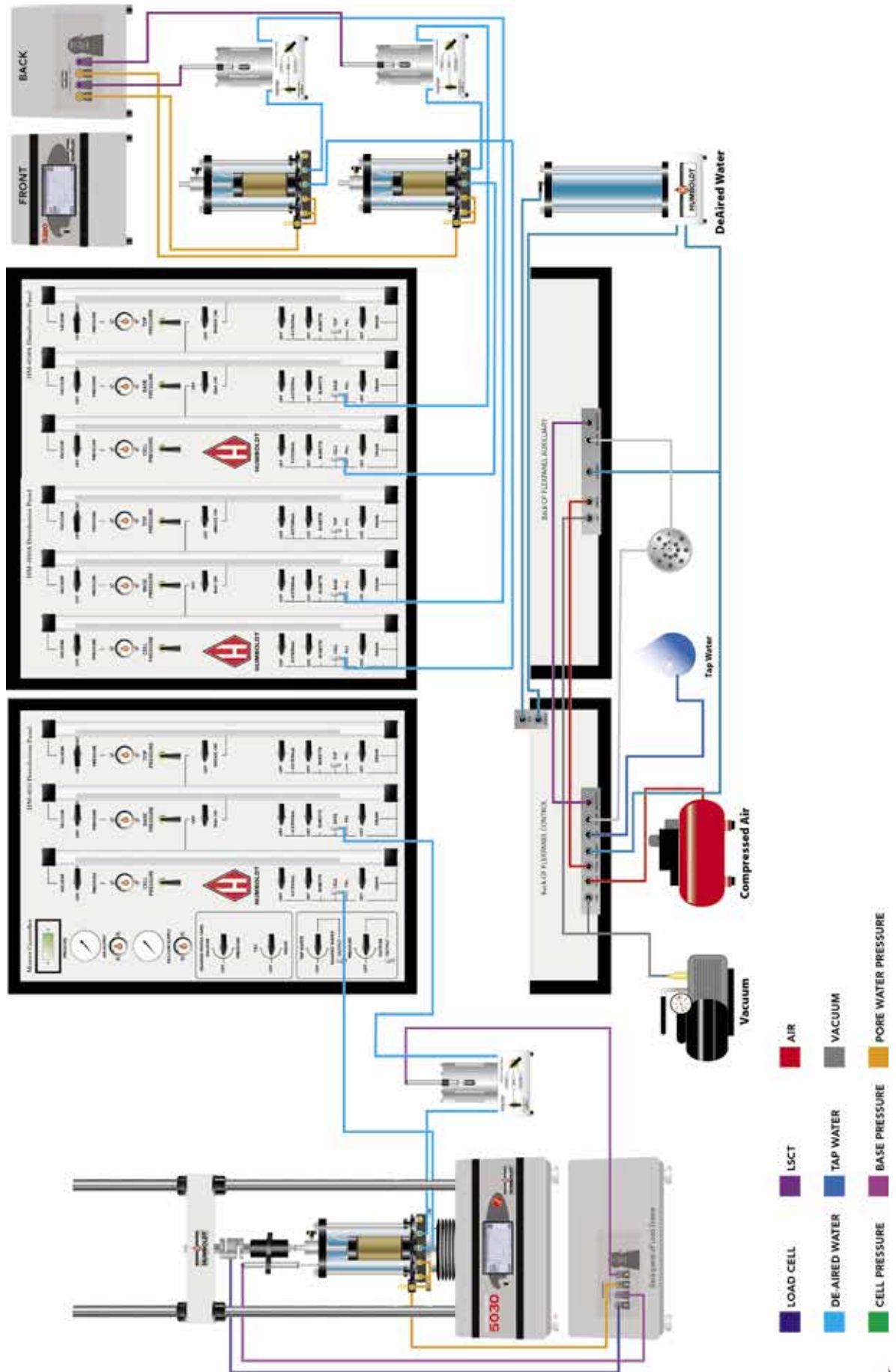

FlexPanel Pressure Control System, 3-Cell Setup

# ELITE SERIES Automated Pressure Controllers



Specifications:	HM-5810	HM-5820
Maximum hydraulic pressure	200-500 psi	
Volumetric capacity	270mL/channel	
Load capacity	N/A	3000 lbf (15kN)
Voltage/Current	110/220V 50/60Hz - 16.0 amps	
Dimensions (L x D x H)	38" x 15" x 20.5" (970 x 385 x 520 mm)	38" x 15" x 45.5" (970 x 385 x 1160 mm)

### Automated, Pressure Controller

ASTM D5084

The HM-5810 is an automated pressure controller designed to handle saturation, consolidation and permeation of a triaxial test sample. In this application it can be used solely for permeability testing as well, eliminating the need for distribution panels, etc. The HM-5810 is all you need to successfully do permeability testing for soil.

Cell, head and tail pressure can be set in increments of 0.1 PSI while volume change is measured to 0.0001cc. The flow rate for permeation can be set from 1 cc/sec (60 cc/min) down to less than 0.000002 cc/sec (0.00012 cc/min). There are three data input channels – one for each pressure transducer, or if you are only doing permeability, you will only need one of the channels/pressure transducers.

The HM-5810 provides an accurate and simplified permeability setup, which eliminates the need for separate distribution panels, and simplifying tubing and control cable setup. By using the integral staging platform, the HM-5810 provides an extremely compact and organized setup.

The HM-5810 is built around Humboldt's integral, data logger with touch-screen control, which allows the HM-5810 to be used as a standalone device capable of full test control and data logging. It can also be controlled by a networked computer at any location with access to the network.

Hydro-Control Pressure Controller **HM-5810.3F**

Shipping wt. 168 lb (76kg)

### Automated, Pressure Controller with Load Frame

ASTM D5084, D2850, D2166, D4767; AASHTO T296, T297, T208

The HM-5820 is an automated pressure controller designed to handle saturation, consolidation and permeation of a triaxial test sample, as well as perform a shear function with the use of its integral HM-5020 Load Frame. This allows the technician to also perform triaxial shear tests without having to purchase an additional unit.

Cell, head and tail pressure can be set in increments of 0.1 PSI while volume change is measured to 0.0001cc. The flow rate for permeation can be set from 1 cc/sec (60 cc/min) down to less than 0.000002 cc/sec (0.00012 cc/min). There are three data input channels – one for each pressure transducer, or if you are only doing permeability, you will only need one of the channels/pressure transducers.

The HM-5820 provides an accurate and compact configuration for performing triaxial tests without the need for separate distribution panels, and simplifying tubing and control cable setup. By using the integral load frame, the HM-5820 provides an extremely compact and organized setup.

The HM-5820 is built around Humboldt's integral, data logger with touch-screen control, which allows the HM-5810 to be used as a standalone device capable of full test control and data logging. It can also be controlled by a networked computer at any location with access to the network.

Triax-Control Pressure Controller **HM-5820.3F**

Shipping wt. 168 lb (76kg)

### Controller Specifications:

Display (Resistive Touch)	7" (178mm) VGA (480 x 800)
Real-time test data	Graphic and tabulation
Processor	Dual 32-bit ARM
RAM	64MB
Memory, non-volatile	4GB
Analog to digital converter	24 bit
Logging speed	up to 50 readings per second
Multi-test storage	1000
Points per test	3000
USB port (front)	export data, import/export calibration data, WiFi
USB port (back)	provides external power for wireless access point
Ethernet connection	for network connectivity
24-bit differential analog to digital converter	2
Ambient temperature sensor	1
Firmware Update	Ethernet or flash drive

### NOTES

Triaxial cells, sample prep materials and additional load cells, etc. are not included and need to be purchased separately. For more information on Humboldt's NEXT software Modules, see page 104-105.





HM-5240.3F



HM-5250.3F



HM-2315  
Shown with HM-2310  
Transducer and HM-  
2310BR Bracket

**Pneumatic Pressure Controller, 150psi (1000kpa)**

The HM-5240.3F is a fully-automated pneumatic pressure controller, which is highly accurate up to 150psi (1000kpa) in pressure and 100cc (100ml) volume in any one direction. It is designed specifically for geotechnical laboratory triaxial testing (UU, CU and CD) and provides control and monitoring of cell pressure, back pressure, pore water measurement and volume change when used with our Elite Series load frames.

The HM-5240 provides four (4) integral and independent data acquisition channels, which can be utilized in stand-alone configuration or accessed through a LAN-networked computer using Humboldt's NEXT software. The unit is built with durable high-quality components and features the use of two electronic regulators to ensure smooth and reliable operation of pressures, as well as precise results.

In stand-alone mode, this pressure controller provides a 7" (178mm) touch-screen controller. This new waterproof, touch screen provides colorful, at-a-glance monitoring of testing functions without the use of a computer. Operator could see all the data in several formats at the controller while the test is running. Then can be viewed simultaneously or downloaded later to a computer in the lab, in the next room or at a different location, while also providing report generation capabilities from within Humboldt's NEXT software or our enhanced test-specific modules.

Specifications	
Maximum Pressure	150psi (1000kpa)
Volume Capacity	100cc (100ml) in any one direction
Voltage	110-220V 50/60Hz - 5.0 amps
Dimension (L x W x H)	13" x 11.5" x 22" (330 x 292 x 559mm)

**Pressure Controller, HM-5240.3F**  
Shipping wt. 40 lb (18.1kg)

**Hydraulic Pressure Controller, 500psi (3500kpa)**

The HM-5250.3F is a fully-automated hydraulic pressure controller, which is highly accurate up to 500psi (3500kpa) in pressure and 200cc (200ml) in volume. It is designed specifically for geotechnical laboratory triaxial testing (UU, CU and CD) and provides control and monitoring of cell pressure, back pressure, pore water measurement and volume change when used with our Elite Series load frames.

The HM-5250 provides four (4) integral and independent data acquisition channels, which can be utilized in stand-alone configuration or accessed through a LAN-networked computer using Humboldt's NEXT software. The unit is built with durable, high-quality components and features the use of stepper motors and precision gears to ensure smooth and reliable operation of pressures, as well as precise results.

In stand-alone mode, this pressure controller provides a 7" (178mm) touch-screen controller. This new waterproof, touch screen provides colorful, at-a-glance monitoring of testing functions without

the use of a computer. Operator could see all the data in several formats at the controller while the test is running. Then can be viewed simultaneously or downloaded later to a computer in the lab, in the next room or at a different location, while also providing report generation capabilities from within Humboldt's NEXT software or our enhanced test-specific modules.

Specifications	
Maximum Pressure	500psi (3500kpa)
Volume Capacity	200cc (200ml)
Voltage	110-220V 50/60Hz - 8.0 amps
Dimension (L x W x H)	13" x 11.5" x 22" (330 x 292 x 559mm)

**Pressure Controller, HM-5250.3F**  
Shipping wt. 75 lb (34kg)

**Volume Change Apparatus, Automatic**

The apparatus is used for measuring the volume change of a soil sample by monitoring the flow of water through the chamber of the unit. The lower assembly contains changeover valves, which when used in conjunction with the upper assembly provides limitless capacity. The unit can be used with a linear strain transducer, a digital indicator, or as part of an automated system. It is accurate to better than ±0.05 ml and is easily de-aired in seconds. Includes connectors, valves, and tubing. Order strain transducer or digital indicator separately.

**Volume Change Apparatus HM-2315**  
Shipping wt. 22 lb (9.9kg)







**Air/Water Bladder Cylinder**

The Humboldt air/water bladder cylinder is used to deliver pressurized de-aired water to the triaxial cell. The bladder acts as an reservoir and interface between the compressed air, used as the pressure source, and the de-aired water, which is used as the pressurizing medium for the sample. The use of the bladder eliminates the reintroduction of air into the de-aired water, while providing a high-degree of accuracy. The cylinder will operate continuously to a maximum pressure of 150 psi (1000 kPa). It is constructed of anodized aluminum top and bottom plates, acrylic cylinder and a fluoroelastomer bladder.

**Bladder Cylinder** **HM-4151A**  
 Shipping wt. 11 lb (4.9kg)

**Bladder**

Replacement bladder for HM-4151A Air/Water Bladder Cylinder.

**Bladder** **HM-4151.1**  
 Shipping wt. 0.5 lbs (0.22kg)

**De-Airing Water System**

The HM-4187A.3F produces 8-liter batches of de-aired water without the use of heat. Combined mechanical agitation and vacuum evacuation removes gasses at much higher rate than conventional heat-boiling methods. Will de-air water to less than 0.5 pph dissolved oxygen in 4 minutes. Requires a vacuum pump, (see page 136) 1/55hp motor 110V, 60Hz. 7.5 x 7.5 x 20" (190 x 190 x 508mm).

**De-Airing System, 120/220V 50/60Hz** **HM-4187A.3F**  
 Shipping wt. 24.5 lb (11.3kg)

**De-Airing Water Tank**

For use with Triaxial/Permeability Distribution Panels. Requires a Vacuum Pump, (see page 136).

**De-Airing Water Tank** **HM-4187H**  
 Shipping wt. 17 lb (7.7kg)

**Strain Transducer**

Strain transducer, 1" (25mm) for use with HM-2315 automatic volume change apparatus.

**Strain Transducer** **HM-2310.10**  
 Shipping wt. 1 lb (0.45kg)

**Transducer Bracket**

Bracket to attach strain transducer to HM-2315 automatic volume change apparatus.

**Transducer Bracket** **HM-2310BR**  
 Shipping wt. 0.1 lb (0.04kg)

**Pore Pressure Transducer**

Highly accurate, 200 psi (1400 kPa) pore pressure transducer. Designed for geotechnical lab applications with outstanding overload protection and protected from corrosive water. Requires input of 10 V DC, with an output of 100 mV. Supplied with 2 meter cable and 5-pin DIN plug.

**Pore Pressure Transducer** **HM-4170**  
 Shipping wt. 0.8 lb (0.36kg)

**Refrigeration Dryer**

Compressed air quality is often overlooked in many labs. Compressed air contains condensate which, when cooled, will turn into water, causing extensive damage to both the compressed air network and testing equipment. Refrigeration dryers actively remove this condensate to achieve near perfectly dry compressed air. The benefits are notable: less system downtime, reduced costs and maintenance, and improved test equipment

life. This refrigeration dryer, thanks to its PlusPack heat exchanger and the most compact dimensions on the market, will prove a major asset in your lab. Dryer uses a 1/2" NPT-F pipe size and nominal flow is: 10 SCFM, 17 Nm<sup>3</sup>/hr and 0.3 Nm<sup>3</sup>/min. based on an ambient and inlet temperature of 100°F (38°C) and a working pressure of 100 psig (7 bar).

**Refrigeration Dryer, 115V 60Hz 1ph** **HM-4221**  
 Shipping wt. 20 lb (9.1kg)

**Desiccant Dryer**

Ideal for drying small volumes of air at the point of use. Convenient in-line mounting saves space. ISO Class 2 dryer. Max. operating pressure is 150 psig. and max operating temperature is 125°F. Total capacity is 4400 ft<sup>3</sup>, Female NPT inlet/outlet size is 0.25 NPTF, bowl size is 1.75 lbs, Height 11 Inches, Width 4.625", Includes one charge of desiccant.

**Desiccant Dryer** **HM-4222**  
 Shipping wt. 5 lb (2.3kg)

**Filter/Regulator**

One-piece, Filter/Regulator, 0-125 psi (0 - 8.6 bar) with standard filtration of 5 micron. Height is 9.77 and width is 2.36. Bowl material is polycarbonate and includes sight glass and pressure gauge.

**Filter/Regulator** **HM-4223**  
 Shipping wt. 1.48lb (0.67kg)





HM-4220



HM-4167



HM-4168



H-1763A



HM-4196.25



HM-4196.12



HM-003175



HM-4150.45



HM-4150.22AS



HM-4197.25



HM-4197.12



HM-4150.78



HM-003176



HM-4150.44



HM-4150.72

**Compressor**

When operating under full load this exceptionally quiet compressor offers a tremendously low noise level of 40 db/A. Each compressor is built with quality in mind, and comes equipped with powder-coated air tank, pressure switch, 1-micron air filter, regulator, and pressure gauges for completely automatic and trouble free operation.

Specifications	
Output	4.2 CFM/120 L/Min
Horse Power	1.0Hp
Tank Size	13 Gal/50 Lt.
Noise Level	42 db/A
Max Pressure	120 PSI (8 Bar)
Operating Pressure	90-120 PSI/6-8 Bar

Compressor, 120V 50/60Hz **HM-4220**  
 Compressor, 220V 50/60Hz **HM-4220.4F**  
 Shipping wt. 147 lbs (66kg)

**High-Vacuum Pump**

Direct-drive two-stage rotary sliding vane high vacuum pump features gas ballast and trap to reduce risk of oil being sucked into the system. Produces free air displacement 85L per minute (3 cu. ft. per minute) and maximum vacuum 29-30". Operating temperature is 30 to 170°F (-1.11 to 76.6°C). Has 0.25" OD intake ports for 0.25" ID tubing. Dimensions: 11.25" x 15.5" x 6.5" (28.6 x 39.4 x 16.5cm).

High-Vacuum Pump, 120V 60Hz **H-1763A**  
 High-Vacuum Pump 230V 50/60Hz **H-1763A.4F**  
 Shipping wt. 31 lbs (14kg)

**Triaxial Installation Kit**

Kit designed to provide fittings, connectors, tubing and tools to complete a triaxial set up installation. Kit includes items in the table below. All items can be purchased individually as well.

Triaxial Kit Components	
.125" Brass Ferrules (10)	HM-4197.12
.25" Brass Ferrules (10)	HM-4197.25
.125" OD Tubing, 10ft.	HM-4196.12
.25" OD Tubing, 100ft.	HM-4196.25
.375" to .25" Reducer Bushing (3)	HM-4150.77
Cutter, Flexible Tubing (1)	HM-000058
Thread Tape, PTFE (1)	HM-000059
Hex wrench, 3/16" (1)	HM-000060
Hex wrench, 7/64" (1)	HM-000061
Hex wrench, 2.5mm (1)	HM-000062
Wrench, 7/16 & 9/16" (1)	HM-000063
Wrench, Adjustable, 6" (1)	HM-000064
Union T Fitting, .25" (5)	HM-4150.45
Quick Valve Coupling, .25" (2)	HM-4150.72
Regulator Elbow, .25" (3)	HM-4150.44
.25" to .125" Reducer Coupling (3)	HM-4150.78
Tube Fitting T, 6mm OD (5)	HM-003175
Push-to-Connect Tube Fitting Coupler, .25" OD (4)	HM-003176
Plug, .25" Nylon (5)	HM-003193
O-ring (Upper Cap), .125" (10)	HM-4150.006
O-ring for Quick-Connect (10)	HM-4196.CXO

Triaxial Installation Kit **HM-4167**  
 Shipping wt. 4.5 lbs (2.04kg)

**Shear & Consolidation Installation Kit**

Kit designed to provide fittings, connectors, tubing and tools to complete a triaxial set up installation. Kit includes items in the table below. All items can be purchased individually as well.

Shear & Consolidation Kit Components	
.25" OD Tubing, 100ft.	HM-4196.25
.375" to .25" Reducer Bushing (3)	HM-4150.77
Cutter, Flexible Tubing (1)	HM-000058
Thread Tape, PTFE (1)	HM-000059
Wrench, Adjustable, 6" (1)	HM-000064
Union T Fitting, .25" (5)	HM-4150.45
Quick Valve Coupling, .25" (2)	HM-4150.72
Regulator Elbow, .25" (3)	HM-4150.44
Tube Fitting T, 6mm OD (5)	HM-003175
Push-to-Connect Tube Fitting Coupler, .25" OD (4)	HM-003176

Shear & Consolidation Installation Kit **HM-4168**  
 Shipping wt. 4.5 lbs (2.04kg)

Replacement Pressure Regulators	
Pressure regulator 2-150 psi w/ fittings	HM-4150.22AS
Positive bias regulator w/ fittings	HM-4150.23AS





HM-3818.28



HM-3701



HM-3820.28

**Compaction Mold, Two-Part**

Two-part aluminum molds with easy-close band clamp closure. Molds include base plate and pedestal, which provides a stable platform for mold during production. Ratio of sample height to diameter is 2:1.

Sample Size	Mold with Base Plate
1.4"	HM-3818.14
1.5"	HM-3818.15
1.875"	HM-3818.18
2.0"	HM-3818.20
2.36"	HM-3818.23
2.5"	HM-3818.25
2.8"	HM-3818.28
4.0"	HM-3818.40
6.0"	HM-3818.60
35mm	HM-3818.35
38mm	HM-3818.38
50mm	HM-3818.50
70mm	HM-3818.70
100mm	HM-3818.100
150mm	HM-3818.150

**Compaction Mold, Two-Part**

See Table

Shipping wt. 15 lbs (6.8kg)

**Compaction Hammer**

Rod with sliding weights on a 2" (51mm) dia foot. Stop allows adjusting height of drop up to 8" (203mm). Includes one .25 lb. (100g) and one 2.25 lb. (1kg) weight.

**Compaction Hammer**

HM-3701

Shipping wt. 6 lbs (2.7kg)

**Compaction Mold, Three-Part with Hammer**

Three-part aluminum molds with easy-close band clamp closure. Molds include base plate and pedestal, which provides a stable platform for mold during production. Ratio of sample height to diameter is 2:1.

Sample Size	Mold with Base Plate
1.4"	HM-3820.14
1.5"	HM-3820.15
1.875"	HM-3820.18
2.0"	HM-3820.20
2.36"	HM-3820.23
2.5"	HM-3820.25
2.8"	HM-3820.28
4.0"	HM-3820.40
6.0"	HM-3820.60
35mm	HM-3820.35
38mm	HM-3820.38
50mm	HM-3820.50
70mm	HM-3820.70
100mm	HM-3820.100
150mm	HM-3820.150

**Compaction Mold, Three-Part**

See Table

Shipping wt. 18 lbs (8.2kg)





HM-3330



HM-3175



HM-4173



HM-4174  
HM-4174M



HM-4198



HM-4189FS

**Soil Sample Trimmer**

Sample trimmer with alignment bar for cutting samples to precise diameters. The HM-3330 handles samples up to 4" samples by employing easily interchangeable top platens. Stainless steel pins in pedestal & top platen hold sample in position. Top platen bearing assembly is lowered & locked and sample trimmed with wire saw. **Order top platens (below) and saw (next page) separately.**

Soil Sample Trimmer, 1" to 4" **HM-3330**  
Shipping wt. 7 lb (3.1kg)

**Top Platens for Soil Trimmer**

Individual, sized, top platens for the soil sample trimmer. Platens are interchangeable.

Size	Model	Size	Model
1.0"	HM-3330.10	4.0"	HM-3330.40
1.4"	HM-3330.14	35mm	HM-3330.35
1.875"	HM-3330.18	38mm	HM-3330.38
2.0"	HM-3330.20	50mm	HM-3330.50
2.5"	HM-3330.25	70mm	HM-3330.70
2.8"	HM-3330.28	100mm	HM-3330.100
3.0"	HM-3330.30		

Top Platens for Soil Trimmer **See Chart**  
Shipping wt. 1 lb (0.45kg)

**Wire Saw**

Sample trimming saw with replaceable wire blade.

Wire Saw **HM-3175**  
Shipping wt. 1 lbs (0.45kg)

**Wire Saw Blade**

Replacement wire for HM-3175 saw.

Wire Saw Blade **HM-3175.1**  
Shipping wt. 0.1 lb (0.04kg)

**Length Comparator**

ASTM D2166, D2850, D4767, BS 1377:8

Length comparator designed to quickly and accurately measure the height of soil samples to within  $\pm 0.1\%$  of the total height. Includes a digital indicator accurate to within 0.0001 inches (0.002mm) with 0 to 1" (0 to 25mm) total range. The comparator is comprised of an upright support 14" (356mm) tall attached to a 6" x 6" x 2" (150 x 150 x 50mm) granite base and includes a 6" (152mm) reference bar. Other reference bars such as 4.0", 3.0" and 2.0" for other sample sizes are available. Reference bar includes Calibration Report traceable to the National Institute of Standards and Technology.

Length Comparator **HM-4173**  
Shipping wt. 20 lb (9.07kg)

**Precision Diameter Tape**

ASTM D2166, D2850, D4767, BS 1377:8

Diameter tapes provide a fast, reliable method for measuring the diameter of concrete, soil and asphalt cores and cylinders. One reading provides round and out-of-round diameters within an accuracy of .001" (.03mm) by means of special graduations and vernier scale. All tapes are made from a stainless alloy and are precision engraved to ensure accuracy. Inch-scale tape has a diameter range of 0.75 to 7" and the metric-scale tape has a diameter of 28 to 200mm. Includes certificate of calibration. Tapes are calibrated and include a NIST-traceable certification.

Precision Diameter Tape, 0.75 to 7" **HM-4174**  
Precision Diameter Tape, 28 to 200mm **HM-4174M**  
Shipping wt. 0.8 lb (0.36kg)

**High-Vacuum Grease**

Effective means of sealing latex membranes to sides of the top cap.

High-Vacuum Grease **HM-4198**  
Shipping wt. 0.8 lb (0.36kg)

**Filter Paper Strips**

Wrapped around sample to accelerate saturation in triaxial testing, 5 x 150mm, Grade 55, 100/pkg.

Filter Paper Strips **HM-4189FS**  
Shipping wt. 0.5 lb (0.22kg)





Latex Membranes, 0.012"	35mm	38mm	50mm	70mm	100mm	150mm	1.4"	1.5"	2.0"	2.8"	4.0"	6.0"
	HM-4180.14	HM-4180.15	HM-4180.20	HM-4180.28	HM-4180.40	HM-4180.60	HM-4180.14	HM-4180.15	HM-4180.20	HM-4180.28	HM-4180.40	HM-4180.60
Latex Membranes, 0.025"	HM-4180.14T	HM-4180.15T	HM-4180.20T	HM-4180.28T	HM-4180.40T	HM-4180.60T	HM-4180.14T	HM-4180.15T	HM-4180.20T	HM-4180.28T	HM-4180.40T	HM-4180.60T

Made from non-porous latex rubber [max. temp. 220°F (104°C)]. Length varies according to sample diameter. All have sufficient length to enclose full length of sample, both top & base of pedestal, and disc—plus enough surplus to allow doubling over the O-rings. 12/pkg. Membranes are 0.012" or 0.025" in thickness.

Membrane Stretcher	35mm	38mm	50mm	70mm	100mm	150mm	1.4"	1.5"	2.0"	2.8"	4.0"	6.0"
	HM-4181.14	HM-4181.15	HM-4181.20	HM-4181.28	HM-4181.40	HM-4181.60	HM-4181.14	HM-4181.15	HM-4181.20	HM-4181.28	HM-4181.40	HM-4181.60

Simple & effective method of sheathing (encasing) sample with latex membrane without creasing or damaging the sleeve.

O-Rings	35mm	38mm	50mm	70mm	100mm	150mm	1.4"	1.5"	2.0"	2.8"	4.0"	6.0"
	HM-4182.14	HM-4182.15	HM-4182.20	HM-4182.28	HM-4182.40	HM-4182.60	HM-4182.14	HM-4182.15	HM-4182.20	HM-4182.28	HM-4182.40	HM-4182.60

For sealing membranes from confining fluid and sample. Neoprene. 12/pkg.

O-Ring Placing Tool	35mm	38mm	50mm	70mm	100mm	150mm	1.4"	1.5"	2.0"	2.8"	4.0"	6.0"
	HM-4183.14	HM-4183.15	HM-4183.20	HM-4183.28	HM-4183.40	HM-4183.60	HM-4183.14	HM-4183.15	HM-4183.20	HM-4183.28	HM-4183.40	HM-4183.60

Positions rings to seal membrane with minimum disturbance to specimen.

Porous Stones	35mm	38mm	50mm	70mm	100mm	150mm	1.4"	1.5"	2.0"	2.8"	4.0"	6.0"
	HM-4184.35	HM-4184.38	HM-4184.50	HM-4184.70	HM-4184.100	HM-4184.150	HM-4184.14	HM-4184.15	HM-4184.20	HM-4184.28	HM-4184.40	HM-4184.60

Used for permeability and triaxial testing to allow even distribution of water through sample. Two stones required per cell, each 1/4" thick (6mm).

Membrane Tester	35mm	38mm	50mm	70mm	100mm	150mm	1.4"	1.5"	2.0"	2.8"	4.0"	6.0"
	HM-4185.14	HM-4185.15	HM-4185.20	HM-4185.28	HM-4185.40	HM-4185.60	HM-4185.14	HM-4185.15	HM-4185.20	HM-4185.28	HM-4185.40	HM-4185.60

Tester is easy to use for quick visual detection of possible flaws in membranes.

2-Part Split Miter Box	35mm	38mm	50mm	70mm	100mm	150mm	1.4"	1.5"	2.0"	2.8"	4.0"	6.0"
	HM-3847.35	HM-3847.38	HM-3847.50	HM-3847.70	HM-3847.100	HM-3847.150	HM-3847.14	HM-3847.15	HM-3847.20	HM-3847.28	HM-3847.40	HM-3847.60

For use with undisturbed samples and for sample trimming of cohesive soils. Made from non-ferrous metal.

2-Part Vacuum Split Former	35mm	38mm	50mm	70mm	100mm	150mm	1.4"	1.5"	2.0"	2.8"	4.0"	6.0"
	HM-3827.35	HM-3827.38	HM-3827.50	HM-3827.70	HM-3827.100	—	HM-3827.14	HM-3827.15	HM-3827.20	HM-3827.28	HM-3827.40	HM-3827.60

For use with non-cohesive soils and disturbed samples. Made from non-ferrous metal. Larger sizes require use of supporting jacks.

Sample Trimmer with Knife	35mm	38mm	50mm	70mm	100mm	150mm	1.4"	1.5"	2.0"	2.8"	4.0"	6.0"
	HM-4186.14	HM-4186.15	HM-4186.20	HM-4186.28	HM-4186.40	HM-3847.60	HM-4186.14	HM-4186.15	HM-4186.20	HM-4186.28	HM-4186.40	HM-3847.60

Used to trim sample ends or cut sample to a specific length.

Filter Paper	35mm	38mm	50mm	70mm	100mm	150mm	1.4"	1.5"	2.0"	2.8"	4.0"	6.0"
	HM-4189.15	HM-4189.15	HM-4189.20	HM-4189.28	HM-4189.40	HM-4189.60	HM-4189.15	HM-4189.15	HM-4189.20	HM-4189.28	HM-4189.40	HM-4189.60

Used to prevent soil from penetrating into porous stones or into a panel. 100/pkg.

Acrylic Disk	35mm	38mm	50mm	70mm	100mm	150mm	1.4"	1.5"	2.0"	2.8"	4.0"	6.0"
	HM-4179.35	HM-4179.38	HM-4179.50	HM-4179.70	HM-4179.100	HM-4179.150	HM-4179.14	HM-4179.15	HM-4179.20	HM-4179.28	HM-4179.40	HM-4179.60

Acrylic disk used in UU triaxial tests.





HM-5320.3F

HM-5330.3F

**Humboldt Elite Series Data Loggers**

Humboldt's Elite Series Data Loggers are specifically designed for use within construction materials testing labs. You can use Humboldt Data Loggers to cost-effectively update your older, non-computerized load frames, direct shear and consolidation machines with computerized data acquisition—increasing lab output, freeing-up technicians and providing more accurate test results.

Humboldt's modular-design, data acquisition concept is designed to give you the most flexible and cost-effective method of data logging for your lab. Rather than having to buy into a large data logging system and then growing into it, Humboldt Data Loggers give you the flexibility and low cost outlay of being able to buy loggers on an "as you grow" basis, increasing your data logging capability as your expansion demands.

Humboldt Data Loggers can be used with a wide variety of transducers, load cells and digital indicators; and both come with Humboldt's, highly-regarded, NEXT software. This software provides robust data acquisition and report generation for those wanting to use a computer to monitor tests and collect test data.

In stand-alone mode, these data loggers provide a 7" (178mm) touch-screen controller, which provides real-time, visual views of your data in both tabular and graphic formats. These new waterproof, touch screens provide colorful, at-a-glance monitoring of testing functions without the use of a computer. Operators can see all the data in several formats at the machine while the test is running. Data can then be viewed simultaneously or downloaded later to a computer in the lab, in the next

room or at a different location, while also providing report generation capabilities from within Humboldt's NEXT software or our enhanced test-specific modules.

When operated from a networked computer the NEXT software provides robust machine and test control, and report generation. It also allows the ability to control and monitor multiple machines from a single computer.

**Humboldt Elite Series Data Logger, Analog**

Provides four individual, 24-bit analog to digital converters with an instrumentation excitation supply of 10 VDC. The analog Logger is ideal for use with instruments, such as pressure transducers, load cells, and strain transducers. It provides data storage for 1000 readings per channel. Voltage: 120/220V 50/60Hz.

**Humboldt Elite Series Data Logger, Analog** HM-5320.3F  
UPS Shipping wt. 5lb (2.2kg)

**Humboldt Elite Series Data Logger, Digital**

Provides four individual, Digital Indicator inputs with an instrumentation excitation supply of 5 VDC. The digital Logger is ideal for use with digital indicators. It provides data storage for 1000 readings per channel. Voltage: 120/220V 50/60Hz.

**Humboldt Elite Series Data Logger, Digital** HM-5330.3F  
UPS Shipping wt. 6 lb (2.7kg)

**Digital Indicator Cable, 6ft.**

For use with HM-4469 & HM-4470 Series digital gauges when used with Elite Series Machines and Digital Data Logger.

**Digital Indicator Cable, 6 ft.** HM-4470C  
UPS Shipping wt. 6 lb (2.7kg)

**Specifications**

Display	7" (178mm) VGA (480 x 800) Resistive-touch screen
Real-time test data	Graphic and tabulation
Processor	Dual 32-bit ARM
RAM	64MB
Memory, non-volatile	4GB
Analog to digital converter	24 bit
Data acquisition	4 Channels
Logging speed	up to 50 readings per second
Multi-test storage	1000
Points per test	3000
USB port (front)	use to export data and import/export calibration data, also use to provide external power for optional WIFI adapter
USB port (back)	provides external power at the back of the machine
Ethernet connection	for network connectivity
Emergency stop	Large button
24-bit differential analog to digital converter (21 bits @1000 samples/sec.	4
Ambient temperature sensor:	1
Limit switches	4
Firmware Update	Ethernet or flash drive





HM-2300.020S



HM-2300.020P shown mounted on crossbar with LSCT and ram



HM-2003E



H-4178.2

**S-type Load Cells**

Load cells are bi-directional for compression loads. Constructed from stainless steel. Load cells can be used with various instrumentation to measure loads. Includes: 6 ft. cable with 5-pin DIN plug and calibration certificate.

Performance Specifications	
Excitation voltage:	10 VDC, max. 15 VDC
Rated output:	3.0 mv/V minimum
Non-linearity:	0.03% full scale Output
Hysteresis:	0.02% FSO
Non-repeatability:	0.01% FSO
Creep (30 minutes):	0.03% FSO
Zero balance:	±1.0% FSO
Bridge resistance:	
Input:	350 ohms, nominal
Output:	350 ohms, ±3.5 ohms
Overload:	
Safe static:	150% of capacity
Ultimate:	175% of capacity
Temperature:	
Compensated range:	0-150°F
Effect on output:	0.0006% FSO/°F
Effect on zero:	0.0008% FSO/°F
Finish:	Nickel-plated or stainless steel
Seal:	Waterproof

- Load Cell, 500 lbf (2.5 kN) HM-2300.005
- Load Cell, 1000 lbf (5 kN) HM-2300.010
- Load Cell, 2000 lbf (10 kN) HM-2300.020
- Load Cell, 5000 lbf (25 kN) HM-2300.050
- Load Cell, 10000 lbf (50 kN) HM-2300.100

Shipping wt. from 1 lb (0.45kg) to 3.5 lbs (1.6kg)

**Submersible Load Cells**

For those concerned with reducing the effects of hysteresis on testing results, we offer a submersible load cell, which is designed to work within the tri-axial cell. Positioning the load cell within the tri-axial cell eliminates the possible drag effect introduced by using a plunger between the sample and an externally-mounted load.

Performance Specifications	
Overload Capacity:	200%
Excitation Voltage:	10 VDC, Maximum
Non-linearity:	0 ± 0.05% Full Scale Output
Hysteresis:	0.05% Full Scale Output
Diameter:	3" (75mm)
Cable Length:	79" (2m)
Height: (excluding Ram)	2" (50mm)

- Load Cell, 1000 lbf (5 kN) HM-2300.010S
- Load Cell, 2000 lbf (10 kN) HM-2300.020S
- Load Cell, 5000 lbf (25 kN) HM-2300.050S

Shipping wt. 1 lb (0.45kg)

**NOTES**

Load Cells are wired for use with Humboldt Equipment. Please contact support for wiring instructions when using with manufacturers' equipment.

**Pancake Load Cells**

Pancake-design load cells are available for those who want to use a load cell design that theoretically provides the least amount of deflection in applications.

Performance Specifications	
Overload Capacity:	150%
Excitation Voltage:	20 VDC, Maximum
Non-linearity:	0 ± 0.05% Full Scale Output
Hysteresis:	0.05% Full Scale Output
Diameter:	4.13" (104.8mm)
Cable Length:	79" (2m)
Height: (excluding Ram)	2.5" (63.5mm)

- Load Cell, 2000 lbf (10 kN) HM-2300.020P
- Load Cell, 5000 lbf (25 kN) HM-2300.050P
- Load Cell, 10000 lbf (50 kN) HM-2300.100P
- Load Cell, 15000 lbf (75 kN) HM-2300.150P
- Load Cell, 25000 lbf (125 kN) HM-2300.250P
- Load Cell, 50000 lbf (250 kN) HM-2300.500P

Shipping wt. 11 lb (5kg)

**Platen, Swivel Top**

4.25" (108mm) diameter top swivel platen.

- Platen, Swivel Top HM-2003E

Shipping wt. 5.2 lb (2.35kg)

**Stud, Threaded**

Threaded stud for attaching S-type load cells to load frame cross beams.

- Stud, Threaded H-4178.2

Shipping wt. 0.2 lb (0.09kg)





**Linear Strain Conversion Transducers (LSCT)**

Extremely accurate and reliable strain gauge instruments. Compact size does not require a module. High resolution and performance superior to LVDT. Stainless steel casing for environmental protection. Operating temperature range 0 to 70°C. Requires input of 10V dc; output up to 6.5 mV per volt.

- Less than 250g spring force on spindle
- Non-linearity better than ± 0.1% of full scale deflection
- Hysteresis-compensated with linearity better than ± 0.1% of full scale in both directions
- Negligible temperature effect

LSCT, 0.4" (10mm)	HM-2310.04
LSCT, 1.0" (25mm)	HM-2310.10
LSCT, 2.0" (50mm)	HM-2310.20
<small>Shipping wt. 0.8 lb (0.36kg)</small>	

**Linear Potentiometer Transducers (LPT)**

Accurate and reliable strain gauge instruments for use with Humboldt's HM-5150, HM-5170 and HM-5120 Load Frames.

Linear Potentiometer Transducer 1.0" (25mm)	HM-2305.10
Linear Potentiometer Transducer 2.0" (50mm)	HM-2305.20
<small>Shipping wt. 0.8 lb (0.36kg)</small>	

**LSCT Displacement Transducer Bracket**

Bracket used with CBR piston.

LSCT Displacement Transducer Bracket	HM-4178BRT
<small>Shipping wt. 0.7 lb (0.32kg)</small>	

**LSCT/LVDT Contact/Mounting Bracket**

Bracket used in mounting LSCT to equipment in replacement of dial gauge.

LSCT/LVDT Mounting Bracket	HM-2310BR
<small>Shipping wt. 0.1 lb (0.04kg)</small>	

**LSCT Triaxial Mounting Bracket**

Bracket used in mounting LSCT or dial gauge to the upper part of a triaxial cell with a 0.625" (15.5mm) dia. ram for strain measurement. (HM-2310BR also required for use with LSCT.)

LSCT Triaxial Mounting Bracket	HM-4193BR
<small>Shipping wt. 2 lbs (0.9kg)</small>	

**Linear Strain Transducer Bracket**

Bracket used to mount HM-2305 LSCTs.

Linear Strain Transducer Bracket	HM-2305BRT
<small>Shipping wt. 0.7 lb (0.32kg)</small>	

**Linear Strain Transducer Bracket**

Bracket used to mount HM-2305 LSCTs to HM-5120 and HM-5170 for Marshall applications.

Linear Strain Transducer Bracket	HM-2505BRSQ
<small>Shipping wt. 0.7 lb (0.32kg)</small>	

**Transducer Data Extension Cable**

Data extension cable for use with load cells, LSCT or pressure devices. Cable is 25ft.(7.6m) length.

Transducer Data Extension Cable	HM-2310C
<small>Shipping wt. 1 lb (0.45kg)</small>	

**Pore Pressure Transducer**

Highly accurate, 200 psi (1400 kPa) pore pressure transducer. Designed for geotechnical lab applications with outstanding overload protection and protected from corrosive water. Requires input of 10 V DC, with an output of 100 mV. Supplied with 2 meter cable and 5-pin DIN plug.

Pore Pressure Transducer	HM-4170
<small>Shipping wt. 0.8 lb (0.36kg)</small>	

**De-Airing Block**

For use with pore pressure transducer.

De-Airing Block	HM-4170B
<small>Shipping wt. 1 lb (0.45kg)</small>	

**Digital Pore Pressure Set**

For accurately measuring and monitoring pore water pressures and back pressure. For determining level of saturation ("B" parameter) during saturation stages of triaxial/permeability tests. Includes readout, pore pressure transducer, and de-airing block assembly.

Digital Pressure Set, 120V 60Hz	HM-4175
Digital Pressure Set, 220V 50/60Hz	HM-4175.4F
<small>Shipping wt. 7 lb (3.1kg)</small>	

**Digital Pressure Transducer**

Solid state transducer/readout unit incorporates the latest semiconductor technology into a high-quality, yet inexpensive strain gauge. Three-digit readout display has ±.25% of full scale accuracy—comparable to others at twice the cost. Bat-

tery operated with very long battery life—typically up to 5 years. On/off button at top of readout has factory set "on" time built into the memory. Readout shuts off automatically after 20 minutes.

Digital Pressure Transducer	HM-4172
<small>Shipping wt. 2 lbs (0.9kg)</small>	

**AC Adapter, 120V 60Hz**

AC adapter for digital indicator, allows indicator to run off AC power.

AC Adapter, 120V 60Hz	HM-4469AC
<small>Shipping wt. 0.6 lb (0.27kg)</small>	

**Data Cable**

For use with HM-4469 and HM-4470 Series Digital Gauges when used with Elite Series Machines and Digital Data Logger. Includes 6ft cable.

Data Cable	HM-4470C
<small>Shipping wt. 0.5 lb (0.23kg)</small>	

**Data Cable**

Upgrade for HM-4169C Data Cable for use with Elite Series Machines and Digital Data Logger. Includes 6ft cable.

Data Cable	HM-4470U
<small>Shipping wt. 0.5 lb (0.23kg)</small>	

**Data Cable**

Data cable for digital indicator, used with HM-2330D.3F Humboldt Logger.

Data Cable	HM-4469C
<small>Shipping wt. 0.5 lb (0.23kg)</small>	

**Multi-Device Cable**

Allows one computer to control multiple daisy-chained machines. For Non-elite machines.

Multi-Device Cable	HM-000379
<small>Shipping wt. 1 lb (0.45kg)</small>	

**Single-Channel Displays**

The HM-2350 provides 4-digit accuracy and the HM-2360 provides 6-digit accuracy.

Single-Channel Display, 120V 60Hz	HM-2350
Single-Channel Display, 220V 50/60Hz	HM-2350.4F
Single-Channel Display, 120V 60Hz	HM-2360
Single-Channel Display, 220V 50/60Hz	HM-2360.4F
<small>Shipping wt. 6 lb (2.7kg)</small>	







**Load Rings**  
ASTM E74

Sometimes referred to as "proving rings," load rings are used with various asphalt, concrete, or soil instrumentation to measure loads, and are ideal for use with our Master Loader compression machines, direct shear machines and other testing equipment. Our high-quality, tensile steel rings have spherical seatings suitable for all shear boxes and load frames. Each load ring is shipped with a fitted gauge or indicator and calibration certificate, and supplied with tables listing all measurement units. 8.25" (210mm) high, 3/4-16 UNF thread female mounting. Available with digital indicators compatible with data acquisition systems. Eight models range in size from 110 to 22,000 lbf (0.5 to 100.0 kN).

Load Ring with Digital Indicator			
lbf	kN	kgf	Model
110	0.5	50	H-4454.001D
220	1.0	100	H-4454.002D
550	2.5	250	H-4454.005D
1100	5.0	500	H-4454.010D
2200	10.0	1000	H-4454.020D
5500	25.0	2500	H-4454.050D
11000	50.0	5000	H-4454.100D
22000	100.0	10000	H-4454.200D

Load Ring with Dial Indicator			
lbf	kN	kgf	Model
110	0.5	50	H-4454.001
220	1.0	100	H-4454.002
550	2.5	250	H-4454.005
1100	5.0	500	H-4454.010
2200	10.0	1000	H-4454.020
5500	25.0	2500	H-4454.050
11000	50.0	5000	H-4454.100
22000	100.0	10000	H-4454.200

Load Rings See Tables  
Shipping wt. 8 lb (3.7kg)

**Dial Gauges**

Indicators are built to American gauge design specifications for accuracy and are used in field and laboratory testing applications. Dials are high-quality, low-friction type, designed for long life and accurate repeatable readings. All dial indicators have continuous graduations and revolution counters that show revolutions of the indicator hand. They are furnished with a lug back (with a 90° mounting hole to be used vertically or horizontally), a regular contact point .25" long, and a dust cap.

Range	Division	Dia.	Brake	Model
.200"	.0001"	2.25"	No	H-4460
.200"	.0001"	2.25"	Yes	H-4461A
.300"	.0001"	2.25"	No	H-4462
.500"	.0001"	2.25"	No	H-4471
1.000"	.001"	2.25"	No	H-4158.1
2.000"	.001"	2.75"	No	H-4463
3.000"	.001"	2.75"	No	H-4464
4.000"	.001"	2.75"	No	H-4465
5.000"	.001"	2.75"	No	H-4466
12mm	.002mm	57mm	No	H-4465.12
25mm	.010mm	57mm	No	H-4465.25
50mm	.020mm	70mm	No	H-4465.50

All dial gauges above feature clockwise rotation. Counter-clockwise models are available for all except: H-4465 and H-4462. To order counter-clockwise models, add CC to the end of the model number.

Dial Gauges See Table  
Shipping wt. 1.3 lb (0.58kg)

**Digital Indicators**

Switchable inch/metric digital indicator is accurate to ±.0001" (.002mm). Instant zero feature. Locks in maximum reading on LCD display with characters 0.240" high and 0.115" wide. Runs either clockwise or counter clockwise. Operates with replaceable batteries or AC power with automatic shutoff.

Will replace any mechanical dial gauge.

Range	Resolution	Model
.250" / 6.35mm	.0001" .002mm	HM-4470.02
.600" / 15.0mm		HM-4470.05
1.0" / 25.4mm		HM-4470.10
2.0" / 50.0mm		HM-4470.20
4.0" / 101.6mm		HM-4470.40

Digital Indicators See Table  
Shipping wt. 1 lb (0.45kg)

**Gauge Contact Point Extensions**

Used in applications where gauges require longer contact points to ensure correct gauge placement. Contact points feature hardened steel points with polished tip to prevent scratching. Points fit all standard indicators and gauges. **Not compatible with H-4471, H-4471CC, H-4465.12, or H-4465.12CC gauges.**

Contact Point Extensions	Model
0.25" (6.4mm) Extension	H-4466.2
0.5" (13mm) Extension	H-4466.5
1" (25mm) Extension	H-4466.10
1.5" (38mm) Extension	H-4466.15
2" (50mm) Extension	H-4466.20
3" (76mm) Extension	H-4466.30
6" (152mm) Extension	H-4466.6

Gauge Contact Point Extensions See Table  
Shipping wt. 0.1 lb (0.04kg)

**Magnetic Indicator Mount**

Convenient, portable mount for mounting indicators and gauges. Mount has magnetic base, which mounts on metallic surfaces. Features non-magnetic stainless steel holding rod, 6 x 0.25" (154 x 6.4mm), set in hardened ball socket. Can be mounted in almost any position.

Magnetic Indicator Mount H-4470  
Shipping wt. 1.3 lb (0.58kg)

**Magnetic Gauge Mount**

Convenient, portable mount for mounting indicators and gauges. Mount has magnetic base, which mounts on metallic surfaces.

Magnetic Gauge Mount HS-4156.14  
Shipping wt. 1.3 lb (0.58kg)





Specifications	
Flow Rate	0 to 8 meters per second
Specimen Size	Accepts 3.0" OD x 2.875" (76.2 x 73mm) ID Shelby Tubes
Dimensions	96" x 40" x 96" (2,438 x 1016 x 2438mm) excludes wheels.

**Erosion Function Apparatus**

The HM-5940 erosion function apparatus (EFA) was designed and built to prevent bridge failures by measuring the erodibility of soil. Used in conjunction with the SRICOS scour prediction method, the HM-5940 can provide more accurate erodibility measurements and scour predictions than previously obtainable. Applications for its use include: scour at bridges, piping of dams, beach erosion and surface erosion problems. In the case of scour at bridges, the EFA leads to improved accuracy on scour depth predictions, offering several advantages over previous test methods. These advantages include: minimum sample disturbance; measurement of erosion rate vs. shear stress; measurement of critical shear stress, and incorporation of the test results from the SRICOS scour prediction method. The HM-5940 erosion function apparatus uses standard 3.0" OD x 2.875" ID (76.2 x 73 mm) Shelby tubes. The SRICOS method improves the accuracy of pier scour predictions. The HM-4000 EFA is designed to be used in conjunction with the SRICOS method of scour prediction. The SRICOS scour prediction method and the HM-5940 erosion function apparatus were developed through research carried out by Jean-Louis Briaud, PHD, PE. and the scour research team at the Texas Transportation Institute of the Texas A&M University

System. In comparison with the HEC-18 equation (a standard for calculating scour predictions), SRICOS generally leads to smaller calculated scour depths and compares more favorably to actual measured scour depths.

- 7" touch screen interface
- Records and tabulates test data.
- Can store hundreds of tests at a time.
- Graphs flow rate vs. time as well as water temperature vs. time
- System can automatically fill the water tank using water level sensors.
- System can automatically cycle between water sump and water fill during tests to maintain lower water temps.
- If hooked up the internet then the machine will auto update with available firmware updates.
- Test data can be exported to USB stick for transfer to a PC with "data download software" from the Humboldt website.
- Motor can push the sample any specific distance customizable by the user.

**The EFA uses either of two variants of the SRICOS method:**

The Extended SRICOS Method:

- 1) Calculate the maximum depth of scour.
- 2) Collect soil samples at the site.
- 3) Test samples in the EFA to obtain the erosion rate vs. the hydraulic shear stress applied.
- 4) Prepare the velocity hydrograph for the bridge.
- 5) Use the SRICOS program with 3 & 4 above as input and generate the depth of scour vs. time over the period covered by the chosen hydrograph.

The Simple SRICOS Method:

- 1) Calculate the maximum depth of scour.
- 2) Collect soil samples at the site.
- 3) Test samples in the EFA to obtain the erosion rate vs. hydraulic shear stress applied.
- 4) Calculate the equivalent time for a given design life of the bridge and for the design velocity.
- 5) Using known equations, calculate the scour depth at the end of the design life.

**Erosion Function Apparatus** **HM-5940**  
Shipping wt. 1500 lbs (680kg)

